

BLOK™ 1 IP

intelion
INTELLIGENT
LITHIUM-ION
BATTERY SYSTEM



Blizzard Lighting, LLC
www.blizzardlighting.com
Waukesha, WI USA
Copyright (c) 2016

TABLE OF CONTENTS

| | |
|--|-----------|
| Blok 1™ IP | 1 |
| 1. Getting Started | 4 |
| What's In The Box? | 4 |
| Getting It Out Of The Box | 4 |
| Powering Up! | 4 |
| Getting A Hold Of Us | 4 |
| Safety Instructions (Don't run with scissors!) | 5 |
| 2. Meet The Blok 1™ IP LED Fixture | 6 |
| Main Features | 6 |
| DMX Quick Reference | 6 |
| The Blok 1™ IP Pin-up Picture | 7 |
| 3. Setup | 8 |
| Fuse Replacement | 8 |
| Mounting/Rigging | 8 |
| Using the AnyFi™ Wireless DMX Receiver | 9 |
| Using the Intelion™ Battery System | 11 |
| 4. Operating Adjustments | 12 |
| Navigating The Control Panel | 12 |
| Control Panel Menu Structure | 13 |
| DMX Mode | 14 |
| Select the DMX Channel Mode | 14 |
| Auto Mode and Auto Speed | 14 |
| Dimming Mode Settings | 14 |
| Custom Programs | 15 |
| Color Calibration Settings | 15 |
| Custom Static Colors | 16 |
| Menu Key Lock Settings | 16 |
| Fixture Reset Functions | 16 |
| Using the IR Remote Control | 17 |
| DMX In-Depth Reference | 18 |
| 5. Appendix | 19 |
| A Quick DMX Lesson | 19 |
| Troubleshooting | 19 |
| Keeping Your Blok 1™ IP As Good As New | 20 |
| Returns (Gasp!) | 20 |
| Shipping Issues | 20 |
| Tech Specs | 21 |
| Dimensional Drawings | 22 |

LITHIUM-ION BATTERY WARNINGS & INFO

YOU MUST READ THESE SAFETY INSTRUCTIONS AND WARNINGS BEFORE USING OR CHARGING YOUR FIXTURES.

LI-ION BATTERIES ARE VOLATILE. FAILURE TO READ AND FOLLOW THE BELOW INSTRUCTIONS MAY RESULT IN FIRE, PERSONAL INJURY AND DAMAGE TO PROPERTY IF CHARGED OR USED IMPROPERLY. BY PURCHASING AND USING THESE FIXTURES, YOU ASSUME ALL RISKS ASSOCIATED WITH LITHIUM BATTERIES. IF YOU DO NOT AGREE WITH THESE CONDITIONS, PLEASE CONSIDER RETURNING THE FIXTURES

- 1. WARNING! TO REDUCE THE RISK OF INJURY AND/OR EQUIPMENT DAMAGE, DO NOT TAMPER WITH THE CHARGING CIRCUITRY IN THIS FIXTURE.** The use of other types of chargers may result in personal injury or equipment damage. Under no circumstances attempt to connect the battery pack to any power supplies or other equipment that is not specifically and expressly designated for use with this model battery pack.
- 2. NEVER CHARGE UNATTENDED.** When charging Li-Ion batteries, you must always remain in constant observation in order to react to potential problems which may occur. Failure to do so may result in fire. Put the battery in a fireproof container, and charge in an isolated area, away from flammable materials. Always have a fire extinguisher ready for emergency use.
- 3. USE THE LITHIUM ION BATTERY PACK ONLY WITH EQUIPMENT SPECIFICALLY AND EXPRESSLY DESIGNATED FOR USE WITH THIS MODEL BATTERY PACK.** Use with other equipment may result in fire, electric shock, personal injury, and/or damage to equipment.
- 4. AVOID DANGEROUS CONDITIONS AND ENVIRONMENTS.** Do not charge the battery pack in damp or wet conditions. Avoid using the pack in direct exposure to rain or snow. Do not use the battery pack or charger in the presence of explosive gases or flammable materials.
- 5. AVOID USING OR STORING THE BATTERY PACK IN EITHER EXTREME COLD OR EXTREME HOT TEMPERATURES.** The battery pack will disable itself under conditions of extreme heat (above 60 °C) and may not function to full performance under conditions of extreme cold (below -20 °C). Storage at elevated temperatures (above 25 °C) will shorten the life of the battery pack.
- 6. DO NOT BURN OR INCINERATE BATTERY PACKS.** Battery packs may explode causing personal injury, fire, and/or damage. Fumes resulting from burning of battery packs may be toxic.
- 7. DO NOT DROP, CRUSH, IMPACT, OR MECHANICALLY ABUSE BATTERY PACKS.** Cease use of fixtures that have suffered a sharp impact, been dropped, run over, or damaged in any other way. Such impacts may cause internal damage that is not externally visible and that, over time, may cause short circuits, battery cell leakage, or other events that may lead to fire, personal injury, and or equipment damage.
- 8. DO NOT DISASSEMBLE BATTERY PACK.** There are no user serviceable parts within battery packs. Disassembly may result in short circuiting or other damage that may cause fire, personal injury, and/or other damage.
- 9. AVOID CONTACT WITH BATTERY CHEMICALS.** If a battery pack leaks battery chemicals, avoid any contact with skin, eyes, or mouth. In the event of contact with skin, wash immediately with soap and water and rinse with vinegar. For eye contact, begin flushing with clean water, immediately call for medical help, and continue flushing for 20 minutes or until medical help arrives.
- 10. STORE IN A COOL, DRY PLACE.** Avoid leaving the fixture in direct sunlight, vehicle cabs, compartments, or unventilated storage buildings during hot summer conditions. Under extreme temperature conditions damage may occur. Elevated temperatures in general shorten the life of your battery pack.

1. GETTING STARTED

What's In The Box?

- 1 x Blok 1™ IP Professional LED Fixture
- An Ever-So-Handy Power Cord
- This Lovely User Manual

Getting It Out Of The Box

Congratulations on purchasing the Blok 1™ IP, the outdoor rated fixture that is small in size but huge on features! Now that you've got your Blok 1™ IP (*or hopefully, IPs*), you should carefully unpack the box and check the contents to ensure that all parts are present and in good condition. If anything looks as if it has been damaged in transit, notify the shipper immediately and keep the packing material for inspection. Again, please save the carton and all packing materials. If a fixture must be returned to the factory, it is important that the fixture be returned in the original box and packing.

Powering Up!

All fixtures must be powered directly off a switched circuit and **cannot be run off a rheostat (variable resistor) or dimmer circuit, even if the rheostat or dimmer channel is used solely for a 0% to 100% switch.**

AC Voltage Switch - Not all fixtures have a voltage select switch, so please verify that the fixture you receive is suitable for your local power supply. See the label on the fixture or refer to the fixture's specifications chart for more information. A fixture's listed current rating is its average current draw under normal conditions. Check the fixture or device carefully to make sure that if a voltage selection switch exists that it is set to the correct line voltage you will use.

Warning! Verify that the voltage select switch on your unit matches the line voltage applied. Damage to your fixture may result if the line voltage applied does not match the voltage indicated on the voltage selector switch. All fixtures must be connected to circuits with a suitable Ground (Earthing).

Getting A Hold Of Us

If something is wrong, please just visit our website at www.blizzardlighting.com/support and open a support ticket. We'll be happy to help, honest.

Disclaimer: The information and specifications contained in this document are subject to change without notice. Blizzard Lighting™ assumes no responsibility or liability for any errors or omissions that may appear in this user manual. Blizzard Lighting™ reserves the right to update the existing document or to create a new document to correct any errors or omissions at any time. You can download the latest version of this document from www.blizzardlighting.com.

| Author: | Date: | Last Edited: | Date: |
|-----------|----------|--------------|----------|
| J. Thomas | 9/7/2016 | J. Thomas | 9/8/2016 |

SAFETY INSTRUCTIONS



Please read these instructions carefully. They include important information about the installation, usage and maintenance of this product.

- Please keep this User Guide for future use. If you sell the unit to someone else, be sure that they also receive this User Guide.
- ALWAYS make sure that you are connecting to the proper voltage, and that the line voltage you are connecting to is not higher than that stated on the decal or rear panel of the fixture.
- Make sure there are no flammable materials close to the unit while operating.
- The unit must be installed in a location with adequate ventilation, at least 20in (50cm) from adjacent surfaces. Be sure that no ventilation slots are blocked.
- ALWAYS disconnect from the power source before servicing or replacing fuse and be sure to replace with same fuse size and type.
- ALWAYS secure fixture using a safety chain. NEVER carry the fixture by its cord. Use its carrying handles.
- DO NOT operate at ambient temperatures higher than 104°F (40°C).
- In the event of a serious operating problem, stop using the unit immediately. NEVER try to repair the unit by yourself. Repairs carried out by unskilled people can lead to damage or malfunction. Please contact the nearest authorized technical assistance center. Always use the same type spare parts.
- NEVER connect the device to a dimmer pack.
- Make sure the power cord is never crimped or damaged.
- Never disconnect the power cord by pulling or tugging on the cord.
- Avoid direct eye exposure to the light source while it is on.

Caution! There are no user serviceable parts inside the unit. Do not open the housing or attempt any repairs yourself. In the unlikely event your unit may require service, please open a support ticket at www.blizzardlighting.com/support.

2. MEET THE BLOK 1™ IP LED FIXTURE

MAIN FEATURES

- Color mixing via 1x 25W RGBAW 5-in-1 COB LEDs
- Built-in 2.4Ghz AnyFi™ wireless DMX receiver
- W-DMX™ & Skywire™ compatible
- Intelion™ lithium-ion battery system
- 3 battery power saving modes
- User-selectable 32-bit dimming curves
- Variable electronic dimming & strobe
- Built-in automated and customizable programs
- Virtual color wheel
- RGBAW color mixing ability in standalone mode
- Micro OLED display menu with 4* touch sensitive buttons
- 5/6/8/11-channel DMX modes
- IR remote control (sold separately)

ADDITIONAL FEATURES

- Rugged and well-built (It hits the gym regularly)
- Super-quiet with natural convection cooling
- Dual mounting brackets for positioning flexibility
- Flicker-free constant-current 1500HZ LED driver
- PowerCon™ compatible AC power input connector

DMX Quick Reference: 5/6/8/11-Channel Modes

| 5-Channel | 6-Channel | 8-Channel | 11-Channel | What It Does |
|-----------|-----------|-----------|------------|--------------------------------|
| -- | 1 | 1 | 1 | Dimmer (0% <--> 100%) |
| 1 | 2 | 2 | 2 | Red Intensity (0% <--> 100%) |
| 2 | 3 | 3 | 3 | Green Intensity (0% <--> 100%) |
| 3 | 4 | 4 | 4 | Blue Intensity (0% <--> 100%) |
| 4 | 5 | 5 | 5 | Amber Intensity (0% <--> 100%) |
| 5 | 6 | 6 | 6 | White Intensity (0% <--> 100%) |
| -- | -- | 7 | 7 | Strobe Effects |
| -- | -- | -- | 8 | Built-In and Custom Programs |
| -- | -- | -- | 9 | Speed (fast <--> slow) |
| -- | -- | -- | 10 | Virtual Color Wheel |
| -- | -- | 8 | 11 | 32-Bit Dimming |

Figure 1: The Blok 1™ IP Pin-Up Picture

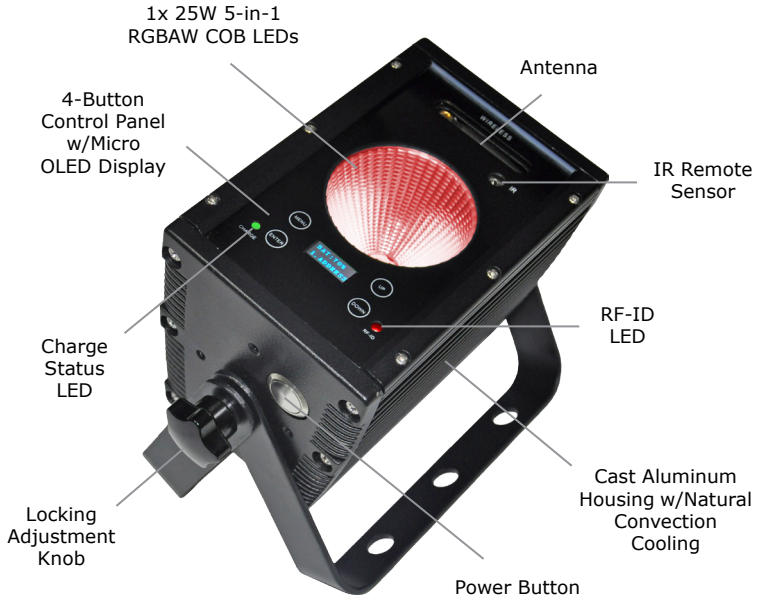

Figure 2: The Rear Connections



3. SETUP



Before replacing a fuse, disconnect power cord. ALWAYS replace with the same type and rating of fuse.

Fuse Replacement

CAUTION! The Blok™ 1 utilizes a high-output switch-mode power supply with an internal fuse. Under normal operating conditions, the fuse should not require replacement. The fuse is field replaceable, however it is an advanced procedure suited to qualified individuals. Should your Weather System™ fuse require replacement, please contact Blizzard Lighting for instructions, or to return for service.

Mounting & Rigging

This fixture may be mounted in any SAFE position provided there is enough room for ventilation.

It is important never to obstruct the fan or vents pathway. Mount the fixture using a suitable "C" or "O" type clamp. The clamp should be rated to hold at least 10x the fixture's weight to ensure structural stability. Do not mount to surfaces with unknown strength, and ensure properly "rated" rigging is used when mounting fixtures overhead.

Adjust the angle of the fixture by loosening both knobs and tilting the fixture. After finding the desired position, retighten both knobs.

- When selecting installation location, take into consideration lamp replacement access (if applicable) and routine maintenance.
- Safety cables MUST ALWAYS be used.

Using the AnyFi™ Wireless DMX Receiver

In addition to the unbridled thrill you already received the first time you turned on your fixture, you'll be delighted to know that your Blok 1™ IP is equipped to work seamlessly with our own Skywire™ 2.4GHz wireless DMX products, as well as W-DMX™ wireless products.

Skywire™ AnyFi™ wireless DMX products feature 512 auto-assigning frequencies in either 6 or 7 groups allowing multiple systems to run simultaneously in the same space, completely free of interference, with reliable wireless communication for over 1000 feet line-of-sight! Using the W-DMX™ wireless protocol in AnyFi™, you can expect the same outstanding wireless range, very easy setup, and leave any worries behind concerning loss of signal due to its built-in FHSS technology (Frequency Hopping Spread Spectrum).



So first, if you would like to use Skywire™ wireless DMX protocol, you will need a wiCICLE® transmitter, Lightcaster™ transceiver, or any Blizzard Lighting controller with this type of built-in wireless transmitter. And if you plan on using W-DMX™ 2.4GHz wireless protocol, you will need a W-DMX™ transceiver to broadcast the signal from your controller, such as our Lightcaster W-DMX™ or LightCaster™ AnyFi.

Ready to move on? Well alrighty!

IMPORTANT - If you are using Blizzard's Lightcaster Any-Fi wireless transmitter in W-DMX compatibility mode along with DMX control software like our Eclipse DMX or Lucid products, you must set the MAB (Mark After Break) in the software to 30us to avoid potential signal timing issues.

1.) Resetting The Wireless

- a.) Navigate the main menu to reach **SET**, press **<ENTER>**, then use the **<UP/DOWN>** buttons until **WIRE** is displayed, then press **<ENTER>** again.
- b.) From here, you can use the **<UP/DOWN>** buttons to highlight **REST** and press **<ENTER>**, select **YES**, then **<ENTER>** to reset the wireless setup.

2.) Select W-DMX™ or Skywire™ Modes

- a.) Make sure the device you are using to transmit signal with is powered on.
- b.) Navigate the main menu to reach **SET**, press **<ENTER>**, then use the **<UP/DOWN>** buttons until **WIRE** is displayed, then press **<ENTER>** again.
- c.) Now use the **<UP/DOWN>** buttons to highlight **KEY** in the menu, and press **<ENTER>**.
- d.) At this point, please note that every time you press the **<ENTER>** button, the wireless LED status indicator changes between 4 colors (**currently 3 are functional**):

- **GREEN:** W-DMX™ 2.4 GHz Receiver Mode
- **YELLOW:** Skywire™ 7CH Receiver Mode (wiCICLE™ & LightCaster Compatible)
- **RED:** Skywire™ 6CH Receiver Mode (AnyFi™ Transmitter Compatible)

Note: The top level **BLUE channel mode currently has no function.*

e.) While the LED indicator is illuminated in **GREEN** (for W-DMX), **YELLOW** (for Skywire 7CH), or **RED** (for Skywire 6CH) press and hold the **<ENTER>** button for **1 second** to confirm and save. Press and hold **<ENTER>** for **3 seconds** to disconnect.

For W-DMX™ connections, you should be done. The fixture will detect the signal!

For Skywire™ wireless connections, continue to **Step 4 on the next page.*

3.) Successful W-DMX™ Connections

The LED status indicator will blink, then turn white if searching for a signal. When a signal connection is established, the LED on the fixture will be solid **GREEN**, if signal is lost the LED will flash **RED**.

W-DMX™ Setup Examples:

- 1.) One transceiver with multiple receiver setups:
 - a.) Power on all units.
 - b.) On the receiving W-DMX fixtures, follow the previous instructions to pair them with the transmitting unit.

- 2.) Multiple transceiver setups, with multiple receivers; e.g. 3 groups consisting of a transceiver & receiver(s) named A, B, and C:
 - a.) Turn power off of all units.
 - b.) Group "A" gets powered on, then follow step 1 above.
 - c.) Group "B" gets powered on, then follow step 1 above.
 - d.) Group "C" gets powered on, then follow step 1 above.

4.) Skywire™ 6/7-Channel Modes: Selecting the Channel Group

1. After selecting either Skywire 2.4GHz Mode in **Step 2** on the previous page, the fixture is ready and waiting for your input to select the frequency group to match that of your transmitting source.

- a.) Tap the **<ENTER>** button repeatedly to scroll through the channel groups:

| Top Menu LED Color | Mode | Channel LED Color | Information |
|--------------------|--|-------------------|-------------|
| | Skywire™ 6CH (AnyFi™ products only) | | CH1 |
| | | | CH2 |
| | | | CH3 |
| | | | CH4 |
| | | | CH5 |
| | | | CH6 |
| | W-DMX Receive (G3 or G4) | | |
| | Skywire™ 7CH (wiCICLE™ compatible) | | CH1 |
| | | | CH2 |
| | | | CH3 |
| | | | CH4 |
| | | | CH5 |
| | | | CH6 |
| | | | CH7 |

- b.) While your chosen group number/color is illuminated on the status LED, press and hold the **<ENTER>** button for 3 seconds.

2. The LED on the transmitter will blink **RED** slowly until communication is established with the receiver. The status LED on the receiving fixtures will be illuminated in the color of the group that it is set on until communication is established.

3. Once the clearest channel is auto-selected, the status LEDs will blink quickly on both the transmitter and receiver. NOTE: The color of the status LED DURING operation does not indicate channel group, instead it indicates whether the unit is transmitting or receiving.

That's It!

Using the Intelion™ Battery System

The Blok 1™ IP features our proprietary Intelion™ Lithium-Ion internal battery system which allows you the flexibility to operate your fixture without AC power for up to 20 hours.

To charge the battery, simply plug the fixture into a power source. The battery will charge whether the fixture is powered on or off. It will even charge while in use! The built-in microprocessor of the battery system controls the charge and overall battery health, so all you need to do is plug and play.

The top section on the display menu shows the battery power level indicator displays the approximate amount of power remaining in the battery. When charging, The CHARGE status LED to the left of the menu display will illuminate in **RED**, then turn **GREEN** when the charge is complete.



A full charge is obtained after charging for at least 5 hours. The fixture will automatically stop charging when the battery is in optimal condition.

Power Output Mode:

Depending on the needs of any given application, you can select either High Power, Medium Power, or Battery Saver Mode, which allows the fixture to run for a longer time at lower output.

- a.) Navigate the menu to reach **SET**, and then **BAT**, and press **<ENTER>**.
- b.) Use the **<UP/DOWN>** to select **High (100%)**, **Middle (75%)** or **Low (50%)**.
- c.) Press **<ENTER>** to confirm the setting.

Note: With average usage of color fades in *High Output Mode*, you can expect the battery life to last up to 10+ hours, color jumping 5+ hrs, or full on for 2.5 hrs. Display color/fade/chase/strobe, and environmental factors including ambient temperature will all impact battery life.

4. OPERATING ADJUSTMENTS

The Control Panel

All the goodies and different modes possible with the Blok 1™ IP are accessed by using the control panel on the front of the fixture. There are 4 control buttons next to the menu display which allow you to navigate through the various control panel menus.

<MENU>

Is used to navigate to the previous higher-level menu item.

<UP>

Scrolls through menu items and numbers in ascending order.

<DOWN>

Scrolls through menu items and numbers in descending order.

<ENTER>

Is used to select and confirm/store the current selection.

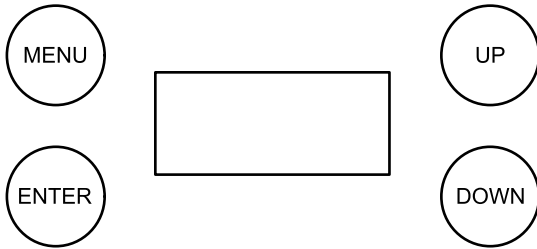

The control panel display shows the menu items you select from the menu map on page #13. When a menu function is selected, the display will show immediately the first available option for the selected menu function. To select a menu item, press **<ENTER>**.

Use the **<UP>** and **<DOWN>** buttons to navigate the menu options. Press the **<ENTER>** button to select the menu function currently displayed, or to enable a menu option. To return to the previous option or menu without changing the value, press the **<MENU>** button.

Control Panel Menu Structure

| | | | | |
|-------------|-----------------------------------|---|--|---------------------------|
| ADDR | 001-512 | | To choose the DMX address | |
| STAT | R | Red intensity (0% <--> 100%) | | |
| | G | Green intensity (0% <--> 100%) | | |
| | B | Blue intensity (0% <--> 100%) | | |
| | A | Amber intensity (0% <--> 100%) | | |
| | W | White intensity (0% <--> 100%) | | |
| | SHUT | Flash/strobe speed (0-255) | | |
| SET | WIRE | REST | Wireless reset | |
| | | KEY | KEY desired wireless mode (color coded LED) | |
| | BAT | <ENTER> | Battery output: High/Middle/Low | |
| | CAL | <ENTER> | To set global intensity levels of each color + USE: YES/NO | |
| | CHMD | 11CH | To run in 11-channel mode | |
| | | 8CH | To run in 8-channel mode | |
| | | 6CH | To run in 6-channel mode | |
| | | 5CH | To run in 5-channel mode | |
| | DIM (dimming) | LIN | Linear dimming curve | |
| | | SQR | Square law curve | |
| | | ISQR | Inverse square law curve | |
| | | SCUR | S-curve | |
| | | LIN. | Linear dimming curve (smooth) | |
| | | SQR. | Square law curve (smooth) | |
| | | ISQR. | Inverse square law curve (smooth) | |
| | | SCUR. | S-curve (smooth) | |
| LOCK | <ENTER> | YES/NO | | |
| CTST | CT01-CT10 | <ENTER> | R/G/B/A/W adjustments for custom color banks 01-10 | |
| AUTO | AT01-AT05 | <ENTER> | Auto programs 1-5 | |
| | ATSP | <ENTER> | Auto Speed | |
| | CHS1 | <ENTER> | Custom program 1 | |
| | CHS2 | <ENTER> | Custom program 2 | |
| | CHS3 | <ENTER> | Custom program 3 | |
| PROG | CHS1-CHS3 Custom programs 1-3. | SC01-SC25 25 scenes for each custom program. | R (0-255) | SHUT (strobe, 0-255) |
| | | | G (0-255) | AUTO (None, AT01-AT05) |
| | | | B (0-255) | ATSP (speed, 0-255) |
| | | | A (0-255) | TIME (duration, 0-255) |
| | | | W (0-255) | WAIT (before fade, 0-255) |
| | | | | USE (use scene, YES/NO) |
| INFO | SOFT | <ENTER> | Software version information | |
| | BATTERY | <ENTER> | 0% - 100% | |
| | POW | <ENTER> | Current automated overheat protection level (100%/80%/50%) | |
| LOAD | ST L | Restore factory settings | | |
| | PR L | Restore factory program settings | | |

DMX Mode

Allows the unit to be controlled by any universal DMX controller.

Set the Starting DMX Address:

- 1.) Navigate the menu using the **<MENU>** button until you reach **Addr.**
- 2.) Use the **<UP/DOWN>** buttons to select a DMX channel from **001-512**.
- 3.) Press the **<ENTER>** button to confirm.

Select the DMX Channel Mode:

- 1.) Navigate the menu to reach **SET**, then press **<ENTER>**.
- 2.) Then use the **<UP/DOWN>** buttons to highlight **CHMD**, and press **<ENTER>**.
- 3.) Use the **<UP/DOWN>** buttons to select either **5CH**, **6CH**, **8CH**, or **11CH** mode.
- 4.) Press the **<ENTER>** button to confirm.

Auto Mode and Auto Speed:

Set the units to run in auto mode at user selectable speeds.

Auto Mode:

- 1.) Use the **<MENU>** and **<UP/DOWN>** buttons to navigate to **AUTO**, and press the **<ENTER>** button.
- 2.) Now use the **<UP/DOWN>** buttons to highlight any program ranging from **AT01-AT05**, and press **<ENTER>**.

Auto Speed:

- 1.) Use the **<MENU>** and **<UP/DOWN>** buttons to navigate to **AUTO** and press **<ENTER>**, then with the **<UP/DOWN>** buttons navigate to **ATSP**, and press the **<ENTER>** button.
- 2.) Make a selection from **0-255**, and press **<ENTER>** to choose a speed (slow <--> fast).

Dimming Mode Settings:

Allows users to set the fixture to use 1 of 4 (x2) dimming curve settings for smoother (and slower) dimming capabilities. In the control panel menu, there are two settings for each curve that are distinguishable from one another by the trailing dot.

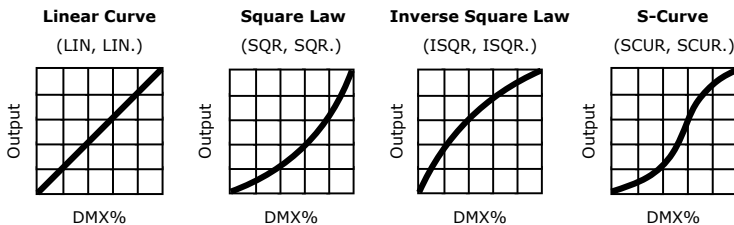

*The curve settings with the trailing dot adds a bit more delay to the curve for a smoother effect.

- 1.) Use the **<MENU>** and **<UP/DOWN>** buttons to navigate to **SET** and press **<ENTER>**, then **<UP/DOWN>** buttons again to scroll to **DIM**, and press the **<ENTER>** button.
- 2.) Now use the **<UP/DOWN>** buttons to highlight either **LIN** (Linear), **SQR** (Square), **ISQR** (Inverse Square), **SCUR** (S-Curve), **LIN.** (Smooth Linear), **SQR.** (Smooth Square), **ISQR.** (Smooth Inverse Square), or **SCUR.** (Smooth S-Curve), then hit **<ENTER>**.

Custom Programs:

Allows users to create up to 3 customizable, 25 scene programs that are directly accessible via the control panel and also in DMX mode.

Creating A Custom Program:

- 1.) Use the **<MENU>** and **<UP/DOWN>** buttons to navigate to **PROG**, and press **<ENTER>**.
- 2.) Now use the **<UP/DOWN>** buttons to highlight your choice of either **CHS1**, **CHS2**, or **CHS3** and press **<ENTER>**.
- 3.) Start with editing scene 1 (**SC01**), customizing it to your liking by using the choices outlined in the table below. You can insert any of its 5 built-in auto programs (**AT01-AT05**), and adjust its speed (**ATSP 0-255**), and set the duration (in seconds) before moving on to the next scene (**TIME 0-255**). You can also add a fade in effect to the start of this scene (**WAIT 0-255**), and/or strobe (**SHUT 0-255**). Finally, if you want to use this scene in your program, *be sure to enable it (USE: YES/NO)*.
- 4.) Repeat the above process to create up to 25 scenes in each of the 3 customizable programs.

| | | |
|-----------------------------|---|---|
| R (0-255) - Red Intensity | SHUT (0-255) - Strobe (slow - fast) | USE (YES/NO) Use Scene in Program? |
| G (0-255) - Green Intensity | AUTO (AT01-AT05) - Auto Programs | IMPORTANT: <i>If USE is set to NO, or TIME is set to 0, the scene will not run!</i> |
| B (0-255) - Blue Intensity | ATSP (0-255) - Auto Speed (fast - slow) | |
| A (0-255) - Amber Intensity | TIME (0-255) - Scene Time (seconds) | |
| W (0-255) - White Intensity | WAIT (0-255) - Fade In (fast - slow) | |

Running A Custom Program:

- 1.) To view your newly created lighting masterpiece, use the **<MENU>** and **<UP/DOWN>** buttons to navigate to **AUTO**, and press **<ENTER>**.
- 2.) Use the **<UP/DOWN>** buttons to highlight your choice of either **CHS1**, **CHS2**, or **CHS3** and press **<ENTER>**. These are also directly accessible from the **Effect Channel** in DMX mode.

Color Calibration Settings:

Allows the user to setup and save 1 customized R/G/B/A/W color balance setting and save it for future use. This custom setting is global, and it will effect all modes.

- 1.) Use the **<MENU>** and **<UP/DOWN>** buttons to navigate to **SET** and press **<ENTER>**, then on while **CAL**, push **<ENTER>** again.
- 2.) Use the **<UP/DOWN>** buttons to highlight either **R** (Red Level), **G** (Green Level), **B** (Blue Level), **A** (Amber Level), or **W** (White Level), then hit **<ENTER>**.
- 3.) Now using the **<UP/DOWN>** buttons, select the maximum level for each color between 000-255 (000=off), and hit **<ENTER>** to confirm your choice.
- 4.) You have now just setup and saved a custom global color calibration setting that you can use at you convenience. To use your custom setting now (or later), press the **<UP/DOWN>** buttons to reach **USE**, and press **<ENTER>**. Then choose either **YES** or **NO** and press **<ENTER>**. When you select **YES**, it enables this custom color calibration globally, and when choosing **NO** the fixture will continue to use the default color calibration settings. Your customized settings will be saved for later use even after powering off the fixture. It can be altered to your liking at any time. Just remember to return to this setting to either enable or disable it when needed.

Custom Static Colors:

Allows the user to create and save up to 10 custom static colors.

Custom Mixing

1.) Use the **<MENU>** and **<UP/DOWN>** buttons to navigate to **STAT** and press **<ENTER>**, then **<UP/DOWN>** buttons to select R/G/B/A/W, and push **<ENTER>** to confirm your selection. Then in the same manner, you can select **SHUT** to add s strobe effect.

Mix and Save Custom Colors (1-10)

1.) Use the **<MENU>** and **<UP/DOWN>** buttons to navigate to **CTST** and press **<ENTER>**, then **<UP/DOWN>** buttons to select a color bank from **CT01-CT10**, and push **<ENTER>** to confirm your selection.

2.) Now use the **<UP/DOWN>** buttons to highlight either **R** (Red Level), **G** (Green Level), **B** (Blue Level), **A** (Amber Level), or **W** (White Level), then hit **<ENTER>**.

3.) Finally, using the **<UP/DOWN>** buttons, select the maximum level for each color between 000-255 (000=off), and hit **<ENTER>** to confirm your choice(s).

4.) These 10 custom colors can be accessed and edited to your liking at any time, and will be saved even after powering off the fixture.

5.) Your custom static colors are directly accessible from the **Effect Channel** in DMX mode.

Menu Key Lock Setting:

Lock the menu buttons until an unlock button sequence is pressed.

Lock Settings:

1.) Use the **<MENU>** and **<UP/DOWN>** buttons to navigate to **LOCK**, and press the **<ENTER>** button.

2.) Now use the **<UP/DOWN>** buttons to highlight **YES** or **NO**, and press **<ENTER>**.

3.) Selecting **NO** will disable the menu lock feature, and **YES** will enable it to prevent accidental button triggering.

4.) To unlock the menu while enabled, press **MENU > UP > DOWN > ENTER** in order (*in a circular motion*) **3 times**. Each button press must be within 2 seconds of each other.

Fixture Reset Functions:

Allows users to reset the fixture to factory default settings, without losing customized settings, or reset the custom programs exclusively.

1.) Use the **<MENU>** and **<UP/DOWN>** buttons to navigate to **LOAD** and press **<ENTER>**, then use the **<UP/DOWN>** buttons to highlight **ST L** or **PR L**, and press **<ENTER>**.

2.) Use the **<UP/DOWN>** buttons to highlight either **YES** or **NO**, then press **<ENTER>**.

3.) The **ST L** reset function will reset all default values **with the exception of** those in **ADDR** (address), **CTST** (10 custom colors), and **PROG** (custom scenes and programs).

4.) The **PR L** reset function will only reset all customized program settings found in the **PROG** settings (custom scenes and programs).

Using the IR Remote Control *(sold separately)*

All the goodies and different modes possible with the Blok™ 1 can be accessed by using the IR remote control *(sold separately)*.

The IR remote control is simple to use. It offers the same functionality of the LED control panel, with the addition of quick access shortcut buttons.

<MENU>

Used to navigate to the previous higher-level menu item.

<UP>

Scrolls through menu items and numbers in ascending order.

<DOWN>

Scrolls through menu items and numbers in descending order.

<ENTER>

Is used to select and confirm/store the current selection.

<R1>, <G1>, <B1>, <A1>, <W1>

Shortcut keys used to access the color settings for Red, Green, Blue, Amber, and White.

<STROBE>

Shortcut key used to access strobe settings. After pressing this button you can use the <UP/DOWN> and <ENTER> buttons to modify the strobe (slow <--> fast).

<AUTO>

Shortcut key used to access auto mode settings. After pressing this button you can use the <UP/DOWN> and <ENTER> buttons to access its built-in auto programs.

<SPEED>

Shortcut key used to access speed settings. After pressing this button you can use the <UP/DOWN> and <ENTER> buttons to select a speed value (fast <--> slow).

<CLEAR>

This will clear the modified values of <R1>, <G1>, <B1>, <A1>, <W1>, <STROBE>, and reset the fixture.

**Some of the buttons on this remote are reserved for future use.*

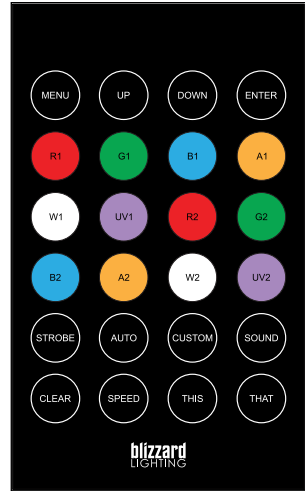

DMX In-Depth Reference: 5/6/8/11-Channel Modes

| 5CH | 6CH | 8CH | 11CH | Value | What It Does |
|-----|-----|-----|------|--|--|
| -- | 1 | 1 | 1 | 000 <--> 255 | Dimmer (0% <--> 100%) |
| 1 | 2 | 2 | 2 | 000 <--> 255 | Red Intensity (0% <--> 100%) |
| 2 | 3 | 3 | 3 | 000 <--> 255 | Green Intensity (0% <--> 100%) |
| 3 | 4 | 4 | 4 | 000 <--> 255 | Blue Intensity (0% <--> 100%) |
| 4 | 5 | 5 | 5 | 000 <--> 255 | Amber Intensity (0% <--> 100%) |
| 5 | 6 | 6 | 6 | 000 <--> 255 | White Intensity (0% <--> 100%) |
| -- | -- | 7 | 7 | 000 <--> 005 006 <--> 115 116 <--> 130 131 <--> 170 171 <--> 210 211 <--> 250 251 <--> 255 | Strobe No strobe Normal strobe (slow <--> fast) No strobe Electronic sine wave (slow <--> fast) Opening pulse (slow <--> fast) Closing pulse (slow <--> fast) No strobe |
| -- | -- | -- | 8 | 000 <--> 005 006 <--> 010 011 <--> 015 016 <--> 020 021 <--> 025 026 <--> 030 031 <--> 035 036 <--> 040 041 <--> 045 046 <--> 050 051 <--> 055 056 <--> 060 061 <--> 065 066 <--> 070 071 <--> 075 076 <--> 080 081 <--> 220 221 <--> 225 226 <--> 230 231 <--> 235 236 <--> 255 | Effect No Function Custom color 1 (CT01 in menu settings) Custom color 2 (CT02 in menu settings) Custom color 3 (CT03 in menu settings) Custom color 4 (CT04 in menu settings) Custom color 5 (CT05 in menu settings) Custom color 6 (CT06 in menu settings) Custom color 7 (CT07 in menu settings) Custom color 8 (CT08 in menu settings) Custom color 9 (CT09 in menu settings) Custom color 10 (CT10 in menu settings) Auto 1 - R, G, B, RG, RB, GB Auto 2 - R↑, R↓, G↑, G↓, B↑, B↓, A↑, A↓, W↑, W↓ Auto 3 - R↑G↑, R↓G↓, R↑B↑, R↓B↓, B↑G↑, B↓G↓ Auto 4 - RGBW↑, RGBW↓ Auto 5 - B, BG↑, BG, B↓G, G, GR↑, GR, G↓R, R, RB↑, RB, R↓B Reserved Custom program 1 (CH01 in menu settings) Custom program 2 (CH02 in menu settings) Custom program 3 (CH03 in menu settings) Reserved |
| -- | -- | -- | 9 | 000 <--> 255 | Speed (fast <--> slow) |
| -- | -- | -- | 10 | 000 <--> 010 011 012 <--> 050 051 052 <--> 090 091 092 <--> 130 131 132 <--> 170 171 172 <--> 210 211 212 <--> 250 251 <--> 255 | Virtual Color Wheel No Function Blue Blue (+ green) Teal Teal (- blue) Green Green (+ red) Yellow Yellow (- green) Red Red (+ blue) Magenta Magenta (- red) Blue |
| -- | -- | 8 | 11 | 000 <--> 010 011 <--> 020 021 <--> 030 031 <--> 040 041 <--> 050 051 <--> 060 061 <--> 070 071 <--> 080 081 <--> 090 091 <--> 255 | Dimming Mode Default (as set in the LED menu) Linear curve Square law curve Inverse square law curve S-curve Linear curve (smooth) Square law curve (smooth) Inverse square law curve (smooth) S-curve (smooth) Default (as set in the LED menu) |

5. APPENDIX

A Quick Lesson On DMX

DMX (aka DMX-512) was created in 1986 by the United States Institute for Theatre Technology (USITT) as a standardized method for connecting lighting consoles to lighting dimmer modules. It was revised in 1990 and again in 2000 to allow more flexibility. The Entertainment Services and Technology Association (ESTA) has since assumed control over the DMX512 standard. It has also been approved and recognized for ANSI standard classification.

DMX covers (and is an abbreviation for) Digital MultipleXed signals. It is the most common communications standard used by lighting and related stage equipment.

DMX provides up to 512 control "channels" per data link. Each of these channels was originally intended to control lamp dimmer levels. You can think of it as 512 faders on a lighting console, connected to 512 light bulbs. Each slider's position is sent over the data link as an 8-bit number having a value between 0 and 255. The value 0 corresponds to the light bulb being completely off while 255 corresponds to the light bulb being fully on.

Each receiving device typically has a means for setting the "starting channel number" that it will respond to. For example, if two 6-channel fixtures are used, the first fixture might be set to start at channel 1 so it would respond to DMX channels 1 through 6, and the next fixture would be set to start at channel 7 so it would respond to channels 7 through 12.

The greatest strength of the DMX communications protocol is that it is very simple and robust. It involves transmitting a reset condition (indicating the start of a new "packet"), a start code, and up to 512 bytes of data. Data packets are transmitted continuously. As soon as one packet is finished, another can begin with no delay if desired (usually another follows within 1 ms). If nothing is changing (i.e. no lamp levels change) the same data will be sent out over and over again. This is a great feature of DMX -- if for some reason the data is not interpreted the first time around, it will be re-sent shortly.

In summary, since its design and evolution in the 1980's DMX has become the standard for lighting control. It is flexible, robust, and scalable, and its ability to control everything from dimmer packs to moving lights to foggers to lasers makes it an indispensable tool for any lighting designer or lighting performer.

Troubleshooting

| Symptom | Solution |
|---|---|
| Light is Dim / Brightness Declines | Check to see if SET > CAL is enabled in the menu. If so, the set values may be too low. Check to INFO > POW in the menu to see if the fixture is in power reduction mode. If yes, take measures for better ventilation. This is automatically triggered to protect the fixture from overheating. |
| No Light Output | Check to ensure fixture is operating under correct mode. |
| Chase Speed Too Fast/Slow | Check to ensure proper setup of speed adjustment. |
| Fixture Not Responding / Responding Erratically | Check to see if the CHMD setting is correct. Check the battery charge level. Check the power cord connection. Reset fixture(s). |

Keeping Your Blok 1™ IP As Good As New

The fixture you've received is a rugged, tough piece of pro lighting equipment, and as long as you take care of it, it will take care of you. That said, like anything, you'll need to take care of it if you want it to operate as designed. You should absolutely keep the fixture clean, especially if you are using it in an environment with a lot of dust, fog, haze, wild animals, wild teenagers or spilled drinks.

Cleaning the optics routinely with a suitable glass cleaner will greatly improve the quality of light output. Keeping the fans free of dust and debris will keep the fixture running cool and prevent damage from overheating.

In transit, keep the fixtures in cases. You wouldn't throw a prized guitar, drumset, or other piece of expensive gear into a gear trailer without a case, and similarly, you shouldn't even think about doing it with your shiny new light fixtures.

Common sense and taking care of your fixtures will be the single biggest thing you can do to keep them running at peak performance and let you worry about designing a great light show, putting on a great concert, or maximizing your client's satisfaction and "wow factor." That's what it's all about, after all!

Returns (Gasp!)

We've taken a lot of precautions to make sure you never even have to worry about sending a defective unit back, or sending a unit in for service. But, like any complex piece of equipment designed and built by humans, once in a while, something doesn't go as planned. If you find yourself with a fixture that isn't behaving like a good little fixture should, you'll need to obtain a Return Authorization (RA).

Don't worry, this is easy. Just go to our website and open a support ticket at www.blizzardlighting.com/support, and we'll issue you an RA. Then, you'll need to send the unit to us using a trackable, pre-paid freight method. We suggest using USPS Priority or UPS. Make sure you carefully pack the fixture for transit, and whenever possible, use the original box & packing for shipping.

When returning your fixture for service, be sure to include the following:

- 1.) Your contact information (Name, Address, Phone Number, Email address).
- 2.) The RA# issued to you
- 3.) A brief description of the problem/symptoms.

We will, at our discretion, repair or replace the fixture. Please remember that any shipping damage which occurs in transit to us is the customer's responsibility, so pack it well!

Shipping Issues

Damage incurred in shipping is the responsibility of the shipper, and must be reported to the carrier immediately upon receipt of the items. Claims must be made within seven (7) days of receipt.

Tech Specs!

| | |
|---------------------------------|---|
| Weight & Dimensions | |
| Width | 9.5 inches (240 mm) |
| Depth | 4.8 inches (122 mm) |
| Height | 7.3 inches (185 mm) |
| Weight | 5.5 lbs (2.5 kg) |
| Power | |
| Operating Voltage | 100V-264VAC, 47-63HZ |
| Power Consumption | 28W |
| Light Source | |
| LED | 1x 25W RGBAW 5-in-1 COB LED |
| Optical | |
| Beam Angle | 30 degree |
| AnyFi™ Wireless Receiver | |
| W-DMX™ Receiver | Frequency Hopping W-DMX™ Protocol |
| Skywire™ Receiver | 2.4GHz ISM (2.402-2.48GHz), 512ch, 6/7 frequency groups |
| Latency | Less Than 5ms |
| Receiver Sensitivity | -94dBm |
| Thermal | |
| Max. Operating Temp. | 104 degrees F (40 degrees C) ambient |
| Control | |
| Protocol | USITT DMX-512 |
| DMX Channels | 5/6/8/11-channel DMX |
| Other Operating Modes | Standalone, Auto, Color Preset |
| Other Information | |
| My blod is typo. | |
| Warranty | 2-year limited warranty, does not cover malfunction caused by damage to LEDs. |

DISCLAIMER:

The power connector fitted to the fixture and fixture cord are designed for compatibility with products manufactured by Neutrik AG, Neutrik USA and their related entities, however they are not manufactured by, affiliated with or endorsed by Neutrik AG, Neutrik USA, or any related entity. Neutrik® and powerCON® are registered trademarks of Neutrik AG.

Dimensional Drawings

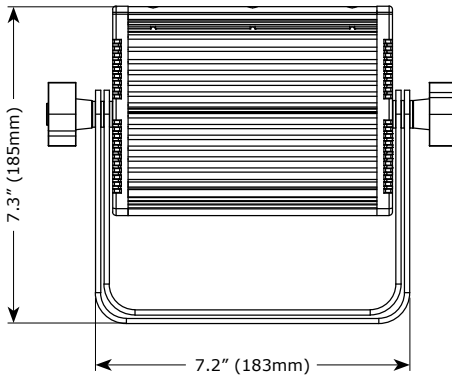
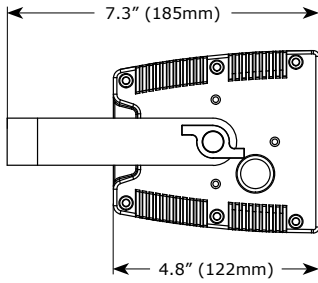
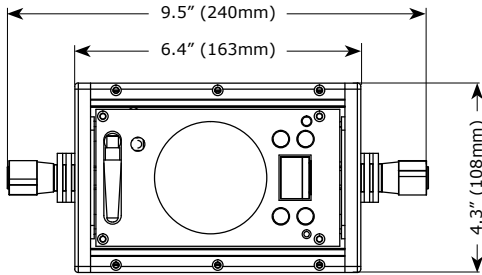

This page is intentionally left blank.



**Enjoy your product!
Our sincerest thanks for your purchase!
--The team @ Blizzard Lighting**