

manta 5



OWNERS MANUAL

Hydrofoiler SL3

ENGLISH - ORIGINAL INSTRUCTIONS

This manual was drafted in English language and may have been translated into other language.
An original English Owners Manual should accompany any translated version.
000123-2 SL3 OWNERS MANUAL



GONE ARE THE CYCLE LANES, THE
NAVIGATION OF TRAFFIC AND TRAILS.



GONE ARE THE WAKES, EMISSIONS AND NOISE
OF COMBUSTION ENGINE WATERCRAFTS.



TIME FOR A NEW ADVENTURE.



From a dream to reality.

Manta5 exists because of cycling enthusiast and water lover Guy Howard-Willis. A tinkerer and entrepreneur at heart, Guy's passion for the outdoors led him to co-found New Zealand's largest multi-sport retailer Torpedo7. After a successful sale of Torpedo7 Guy leapt right into his next venture – to create new world sport.

The hydrofoiling bike concept literally came to Guy's mind in a dream – a dream where he pushed off from his holiday home jetty and rode a bicycle-type product that brought him the same feeling and freedom as his road bike. He cruised out into the bay before being greeted by a pod of dolphins which swam alongside him as he rode.

He woke up but the dream stuck with him and he started the Manta5 journey.



Our Founder's vision

"I want these bikes to go well beyond just being a leisure product - I want it to be a sports product. If you can race it then it's competitive, and if it's competitive then one day it could be an Olympic sport."

Guy Howard-Willis, Founder & Director of Manta5

Welcome to the new adventure.

We'll see you out there.





1. INTRODUCTION TO THE MANTAS HYDROFOILER SL3	8	5.4 Pre-flight checks.....	39
2. SAFETY, WARNINGS & DISCLAIMERS	9	6. RIDING INSTRUCTIONS	40
2.1 Important symbols & warnings.....	9	6.1 Ride Controller introduction.....	41
2.2 Major warnings.....	10	6.2 Using the Ride Controller.....	43
2.3 Safety when learning to ride	10	6.3 Powering ON - standby mode	44
2.4 Hydropack Battery safety.....	11	6.4 Engage motor	44
3. UNBOXING	14	6.5 Entering the water	45
3.1 Box 1 - Chassis.....	14	6.6 Mounting.....	46
3.2 Box 2 - Drivetrain	15	6.7 Launching	48
3.3 Box 3 - Rear Foil.....	16	6.8 Turning	51
3.4 Box 4 - Hydropack Battery	16	6.9 Returning to land	52
4. ASSEMBLY	17	6.10 Powering OFF.....	52
4.1 Tools provided.....	17	7. MAINTENANCE	53
4.2 Charging the Hydropack Battery	18	7.1 Recommended maintenance after each ride.....	54
4.3 Assemble the Tiller	19	7.1 Hydropack Battery maintenance & storage.....	59
4.4 Attach Drivetrain to Rear Foil	20	7.2 Chassis and Drivetrain storage.....	59
4.5 Attach Chassis to Drivetrain	22	7.3 Foil storage.....	59
4.6 Attach Tiller to Chassis.....	24	8. PRODUCT SUPPORT	60
4.7 Mount the Seat Post.....	25	8.1 Warranty registration.....	60
4.8 Attach the Pedals.....	27	8.2 Diagnosis & repairs.....	61
4.9 Adjust the Handlebars	28	8.3 Servicing requirements.....	61
4.10 Connect the Battery to the Chassis	29	8.4 Hydrofoiler SL3 service log.....	62
5. BEFORE YOU RIDE	32	9. MANTAS GLOBAL WARRANTY	63
5.1 Recommended transportation.....	33	9.1 What is covered?	63
5.2 Location selection.....	33	9.2 What is not covered?	64
5.3 Waterside assembly	34	9.3 How to make a claim	64

1. Introduction to the Manta5 Hydrofoiler SL3







- | | | | |
|----|--|----|----------------------------------|
| a. | Hydropack battery (600 or 1000) | m. | Stem |
| b. | Battery cable | n. | Saddle |
| c. | Chassis (Sharkskin Grey or Orca White) | o. | Seat post |
| d. | Tiller | p. | Cranks |
| e. | Mini tiller | q. | Pedals |
| f. | Canard front foil | r. | Nose cone |
| g. | Rear foil (FC2 or Carbon HE2) | s. | Cowling |
| h. | Propeller | t. | Foil shoe |
| i. | Propeller shroud | u. | Tiller quick connect |
| j. | Ride controller | v. | Chassis-drivetrain quick connect |
| k. | Handlebar | w. | Bayonet upright |
| l. | Grips | | |



2. Safety, warnings & disclaimers

All information in the section with regards to safety, warnings and disclaimers are subject to change at the sole discretion of Manta5. The information provided in this Owner's Manual represents the most up-to-date information available at the date of release. For the most current information, please visit the Manta5 website: <https://manta5.com/support/hydrofoiler-sl3-technical-support/>

2.1 IMPORTANT SYMBOLS & WARNINGS

	<p>WARNING: Warns of hazards which could result in personal injury or threat to health, including potential danger zones in which any exposed person (wholly or partially within) is subject to a risk to their health or safety.</p>
	<p>CAUTION: Indicates a potentially hazardous situation, which, if not avoided, may result in risk to user health or safety or, is an alert against unsafe practice.</p>
	<p>NOTICE: Alert of information of particular importance which if not adhered to could result in damage to your hydrofoiler or void your warranty.</p>
	<p>INFORMATION: Indicates information of particular importance, or a tip noting key information to improve your experience with your Hydrofoiler.</p>

2.2 MAJOR WARNINGS

Use of this product and participation in the foil biking involves inherent risks of injury or death. To reduce risks:

- Ride in water conditions that do not exceed the skills of the rider either on bike or in water.
- Riders should remain within reasonable swimming distance to shore at all times.
- Attempting to ride in rough water, or in waves can increase the risk of injury or death.
- Do not use in shallow water, near swimmers or other watercraft.
- Always wear a suitable personal floatation device that is approved by your relevant local regulating body.
- Riders are recommended to wear suitable aquatic footwear and swimwear to protect from potential injury.
- Understand and abide by your local maritime regulations.
- When losing control of the bike, push off pedals to fall away from the bike.
- Never ride after consuming drugs or alcohol.
- Never ride without a suitable communication device or supervision from the land.
- The Hydrofoiler SL3 is for a single rider only. It shall not be towed or used for towing, and should not be used in surf exceeding the intended use or operating conditions.
- Read the manuals before use.
- Always tell someone where you are going and when you expect to return.

2.3 SAFETY WHEN LEARNING TO RIDE

To help prevent serious injury or death, it is important to learn how to ride the Hydrofoiler SL3 correctly. All riders must read and understand the Riding Instructions in section 8. Supplementary to the Riding Instructions found within this manual, Manta5 has created a comprehensive library of instructional rider training video available on the Manta5 website. Before attempting to ride the SL3, all persons must also watch and understand these instructional videos.



<https://training.manta5.com/>

2.4 HYDROPACK BATTERY SAFETY



Lithium-ion batteries can present a serious risk to life and/or property if damaged, defective or improperly used. If the battery exhibits the signs below or any unusual behaviour take immediate action.

- Only use the Manta5 charger provided
- Never charge unattended
- Ensure battery is stable when stored

Manta5 Hydropack batteries have two layers of protection. The transparent outer housing assists visual inspection for any possible damage or water ingress. Before and after each ride immediately inspect for signs of damage or water entry.

If the battery is malfunctioning or housing is damaged immediately discontinue use. Move the battery to an open area away from people and property if safe to do so. In all cases contact your authorised reseller immediately. When storing batteries in confined quarters e.g. a boat, we recommend use of a Zarges (or equivalent) case.

ADVISED ACTION IF YOU NOTICE:

- **DROPPED/DAMAGED CRACKED HOUSING: DO NOT USE.** Move the battery into an open area away from water, people and property if safe to do so and contact Manta5. (See contact information below)
- **EXTREMELY HOT TEMPERATURE AND/OR BATTERY HOUSING DEFORMING: DO NOT USE.** Move the battery into an open area away from people and property if safe to do so. Call local emergency services.

CONTACT MANTA5:

- EUROPE/UK: +44 208 089 7892
- UNITED STATES: +1 786 605 0067
- REST OF WORLD +64 800 114 235
- EMAIL: SUPPORT@MANTA5.COM

WARNING

- **RISK OF FIRE OR EXPLOSION:** Risk of fire or overheating in failure may result in: gases, liquids, vapours or other substances produced, fire damage, injury. In case of battery fire, the battery cell(s) could explode. If a battery emits excessive heat, smoke or unfamiliar audible noises then there is risk of extreme temperatures and/or fire, with the possibility of hot material being ejected. Call emergency services if necessary. Never handle or approach the battery unless it has cooled down and is wrapped in a fire blanket or similar.
- **RISK OF FIRE:** Lithium-ion battery packs can be dangerous if charged incorrectly. Use only the battery charger supplied by Manta5 for charging the Hydrofoiler SL3 lithium-ion battery.
- **RISK OF FIRE:** Do not use the Manta5 battery charger with any other batteries.
- **RISK OF FIRE:** Never connect the charger to an unregulated generator.
- **RISK OF FIRE:** Never let a battery be charged unattended. The battery and charger can get hot while charging. Do not charge near any sources of heat, humidity, water, chemicals or flammable materials and never cover the charger or battery with clothes or other objects.

CAUTION: RISK OF INJURY

- **Broken Battery Housing:** Do not use the battery if the battery casing is broken or if the battery emits an unusual odor, smoke, or excessive heat or leaks any substance. Avoid contact with any substance seeping from the battery.
- **Toxic Substances:** The cells within the batteries contain toxic substances. Do not attempt to open the battery. Do not insert any object into the battery or use any device to pry at the battery casing. If you insert an object into any of the battery ports or openings you could suffer electric shock, injury, burns, or cause a fire. The battery is fitted with tamper-proof fasteners. Attempting to open the battery casing will damage the casing and could release toxic and harmful substances and will render the pack unusable and void any warranty.

NOTICE

- **Submerging:** Do not submerge the batteries and bike separately whilst powered on without the motor properly connected. This could short-circuit the battery and cause a failure.
- **Charging Malfunction:** In the event of a malfunction during charging, isolate the energy sources by switching off and unplugging the charger from the wall mains socket. Stand clear and monitor the situation. Allow the battery to cool before handling it.



3. Unboxing

3.1 BOX 1 - CHASSIS

Dimensions: 1300 mm x 900 mm x 250 mm | Weight: 13 kg

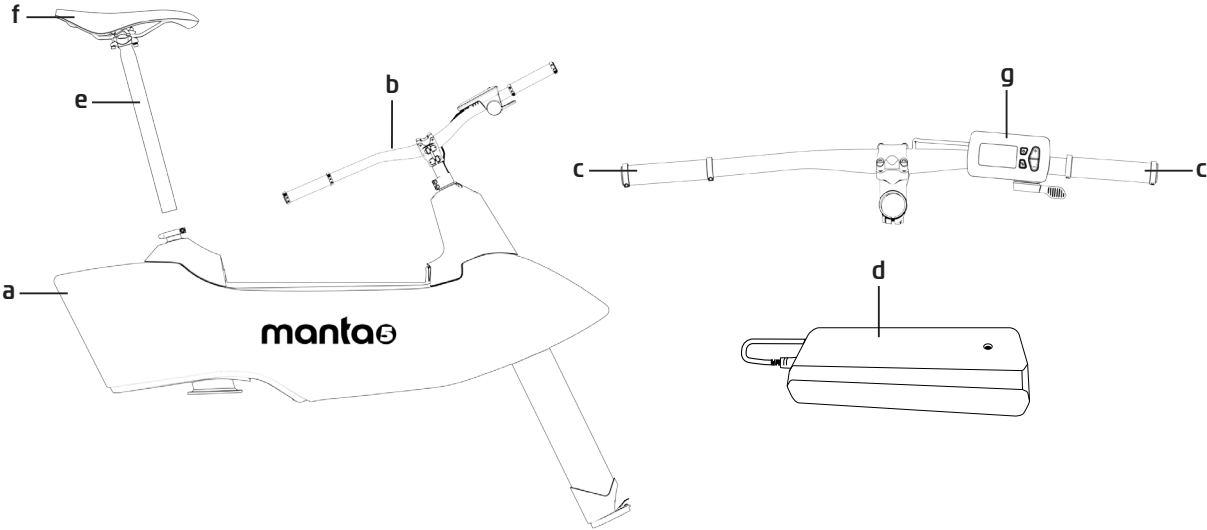

- a. Chassis
- b. Handlebars
- c. Grips
- d. Hydropack battery charger
- e. Seat post
- f. Saddle
- g. Ride controller

3.2 BOX 2 - DRIVETRAIN

Dimensions: 950 mm x 550 mm x 220 mm | Weight: 17 kg

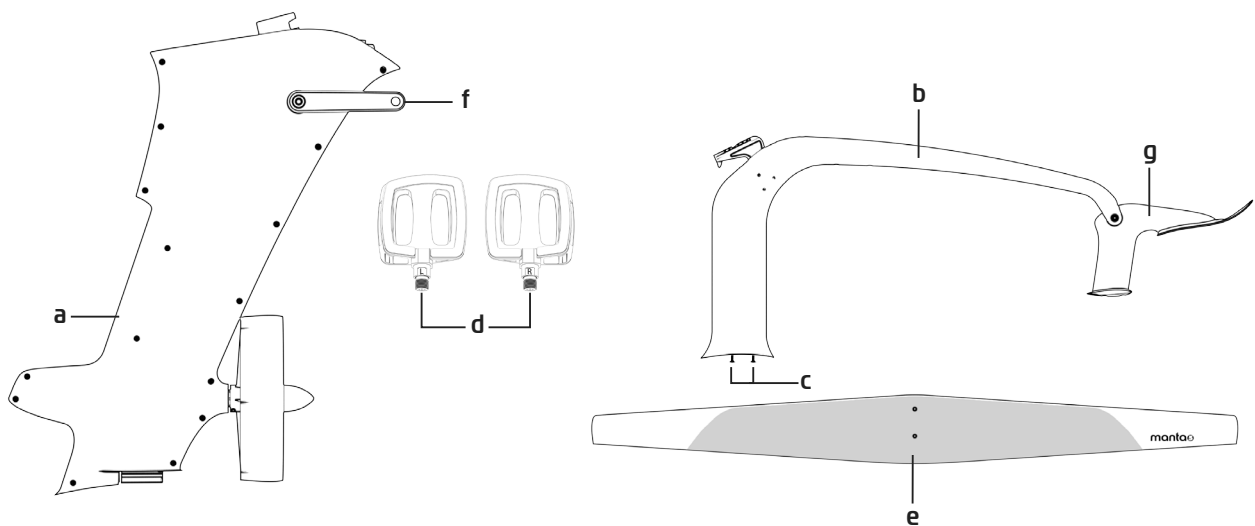

- a. Drivetrain
- b. Tiller
- c. Front foil screws
- d. Pedals
- e. Front foil
- f. Cranks (Assembled)
- g. Mini tiller (Assembled)

3.3 BOX 3 - REAR FOIL

Dimensions: 2040 mm x 280 mm x 100 mm | Weight: 5kg

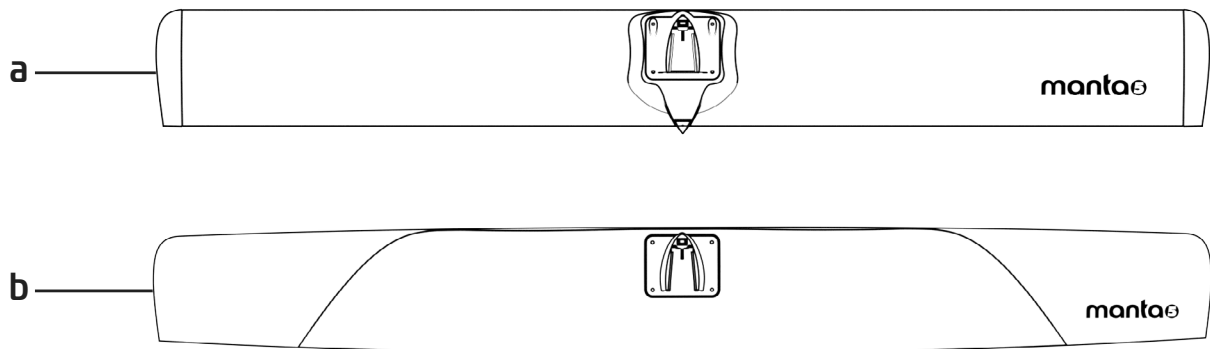

- a. Rear foil: FC2 Fixed Chord (Supplied in SL3 & SL3+ Variants)
- b. Rear foil: HE2 Carbon & FC2 Fixed Chord (Both supplied in SL3 Pro)

3.4 BOX 4 - HYDROPACK BATTERY

Dimensions: 4750 mm x 2600 mm x 1650 mm

Weight: Hydropack 1000: 8kg | Hydropack 600: 5kg

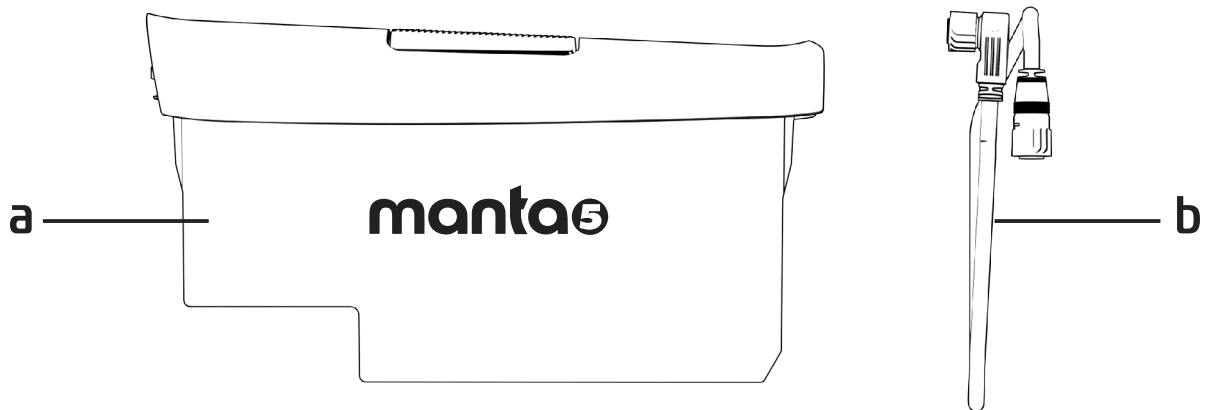

SL3

- a. Hydropack 600 battery
- b. Battery cable

SL3+ / SL3 Pro

- a. Hydropack 1000 battery
- b. Battery cable



4. ASSEMBLY

CAUTION

- **Handling:** Where necessary get help to assemble, handle, lift, transport or manoeuvre the Hydrofoiler SL3 to avoid muscle strain.
- **Handle with Care:** Some parts of the Hydrofoiler SL3 could injure you if mishandled.
- **Disassembly:** The Hydrofoiler SL3 contains some complex items such as the battery, motor and gearboxes that cannot be dismantled by the user. Where events uncover topics not covered in the manuals then please see your nearest Authorised Reseller or Service Centre.
- **Modifications:** Modifications to your Hydrofoiler could make it unsafe, so only replace parts with official Manta5 replacements which have been carefully designed and tested.

4.1 TOOLS PROVIDED

- 2.5mm Allen key (barrel nuts)
- 3mm Allen key (grip removal)
- 4 mm Allen key (canard front foil, stems)
- 5mm Allen key (gearbox)

- 6mm Allen key (rear foil and pedals)
- 8mm Allen key (crank removal)
- 13 mm spanner (propeller)

4.2 CHARGING THE HYDROPACK BATTERY

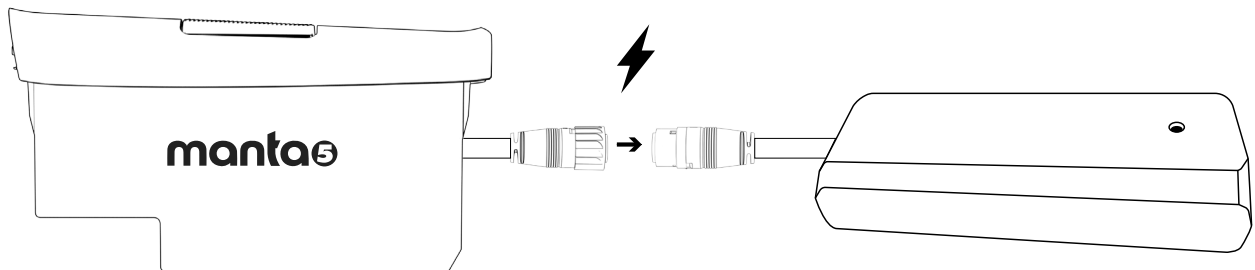

1. Check for any damage to the Hydropack battery that could have been caused during transport. If any damage is suspected, see section Section 2.4, page 11 for instructions.
2. Plug the battery into the charging cable – when pushing the plug in firmly you should hear a click when connected.
3. Ensure the battery is safely connected to the charger by checking that the red dot on the cable is not visible.
4. Orientate the battery upright, with the handle on top.
5. Once confirmed it is connected correctly, plug the charger into the wall. During charging the LED will illuminate red, once charging is complete the LED will be illuminated green.

When you first receive your Hydrofoiler, the Hydropack battery will be partially charged. To get the best life out of your battery; ensure to charge to full capacity before using for the first time.

Lithium batteries are at their most vulnerable state at full charge and should not be stored at 100% charge where possible. It is best to only charge the battery directly before use.

Charge the battery in a cool, dry, well-ventilated location on a non-flammable surface. The battery should not be left to charge unsupervised and there should be a functional smoke alarm in the room.

⚠ NOTICE: Do not charge the battery in wet, high-temperature or high-humidity environments. This means out of direct sunlight, and away from bath/shower-rooms and similar. The battery will not charge if it is 0°C (32°F) or less and greater than 40°C (104°F).

4.3 ASSEMBLE THE TILLER

The tiller comes with the mini-tiller already attached. However, the canard front foil also needs to be attached to the tiller.

1. Remove the front foil screws from the tiller.
2. Place the canard front foil on the ground with the white painted features facing upwards. The leading edge (front) of the foil is painted white.

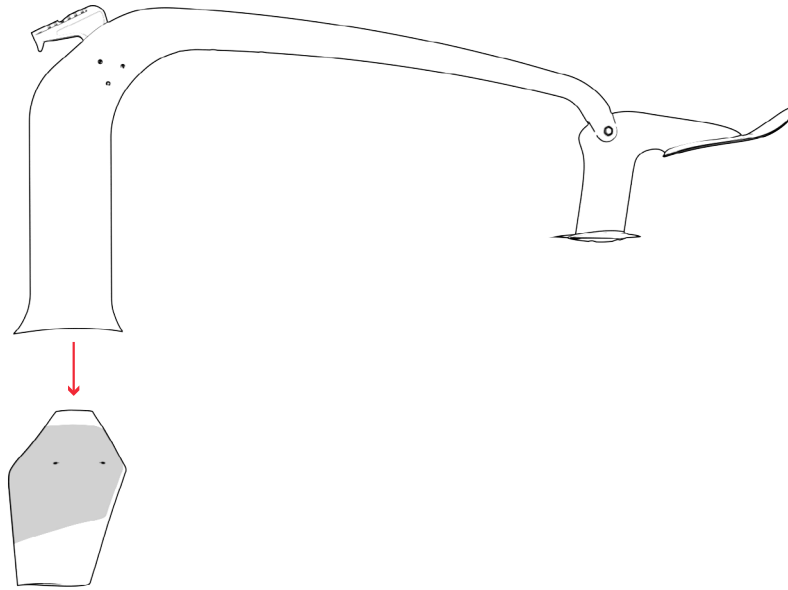

3. Holding the tiller upside down, align the holes with the fuse screws.

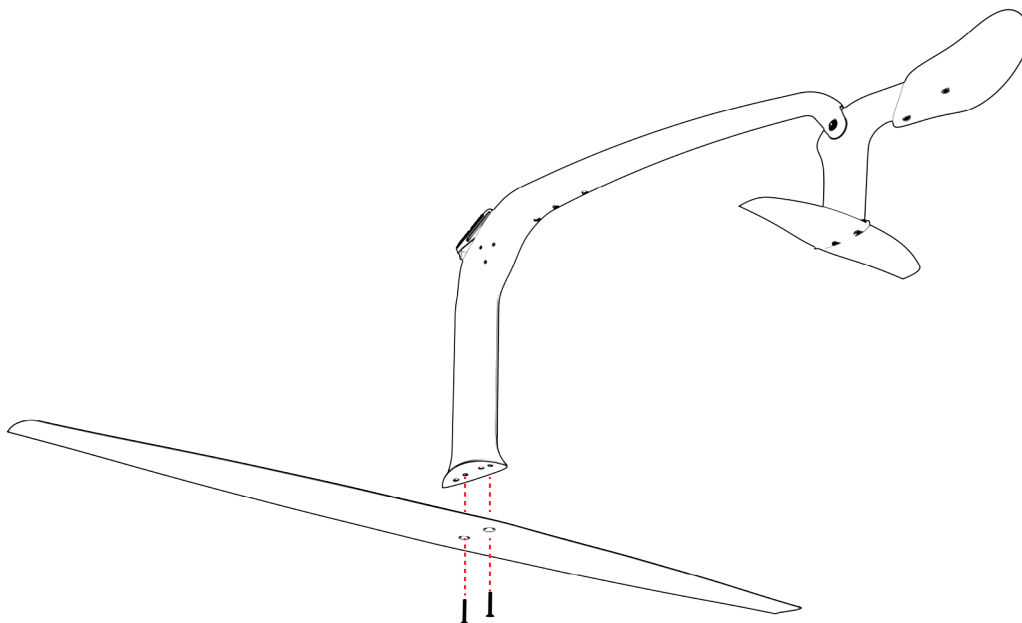

4. Attach the front foil to the tiller using the two M6 fuse screws. Tighten firmly using the 4mm Allen key, without using excessive force.

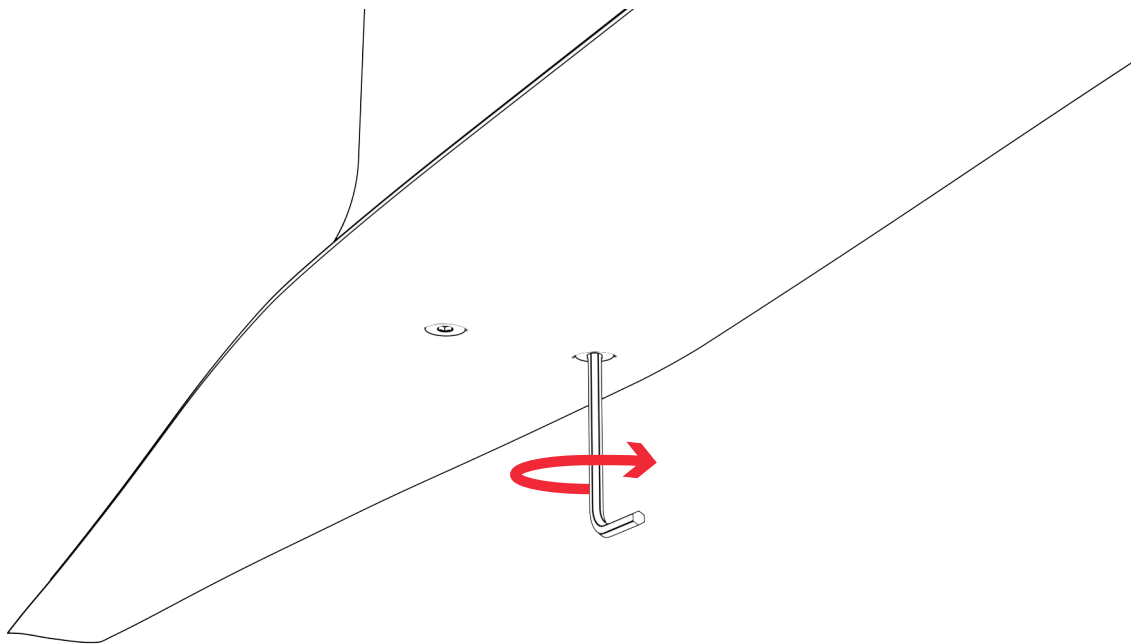

⚠ Check front foil screws are tight before every ride.

4.4 ATTACH DRIVETRAIN TO REAR FOIL

Rear foils comes with the rear foil Shoe already attached.

1. Find an even surface where the rear foil can lay flat on the ground.



2. After placing the rear foil on the ground, align the drivetrain and slot the bayonet upright into the rear foil shoe.

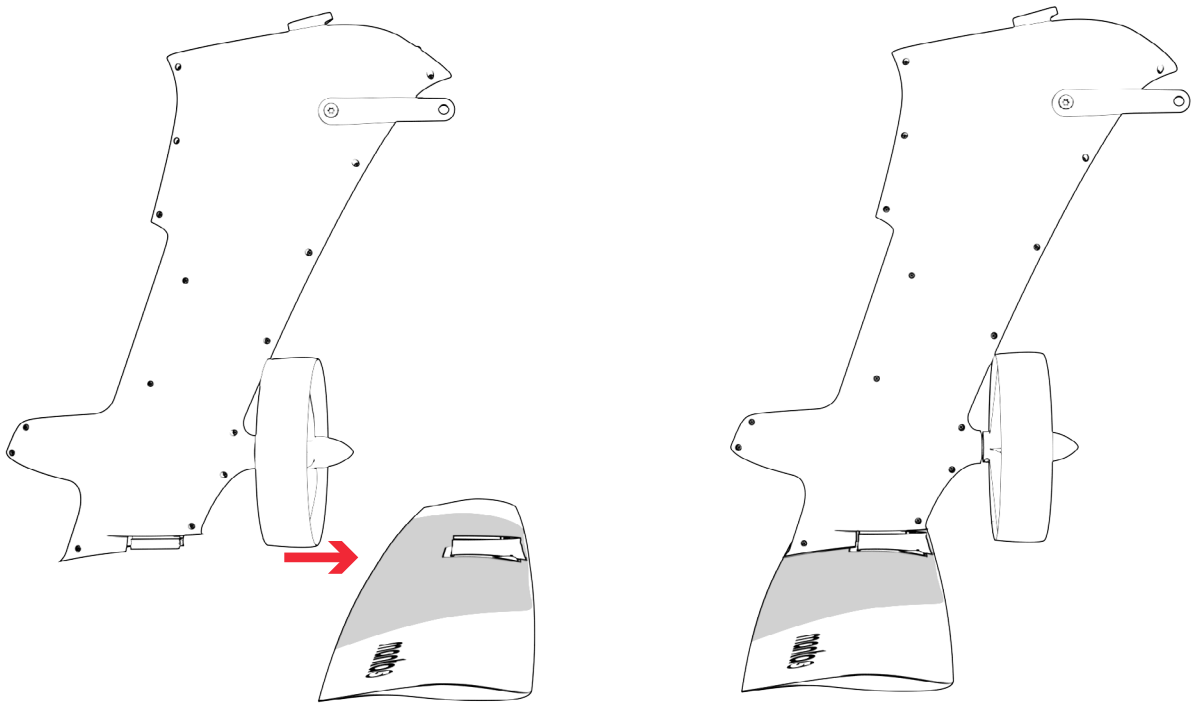

3. Use the 6mm Allen key provided to screw the fastening bolt on the front of the rear foil shoe. Ensure the drivetrain is pushed firmly to ensure the fastening bolt connects to the thread in the bayonet upright.

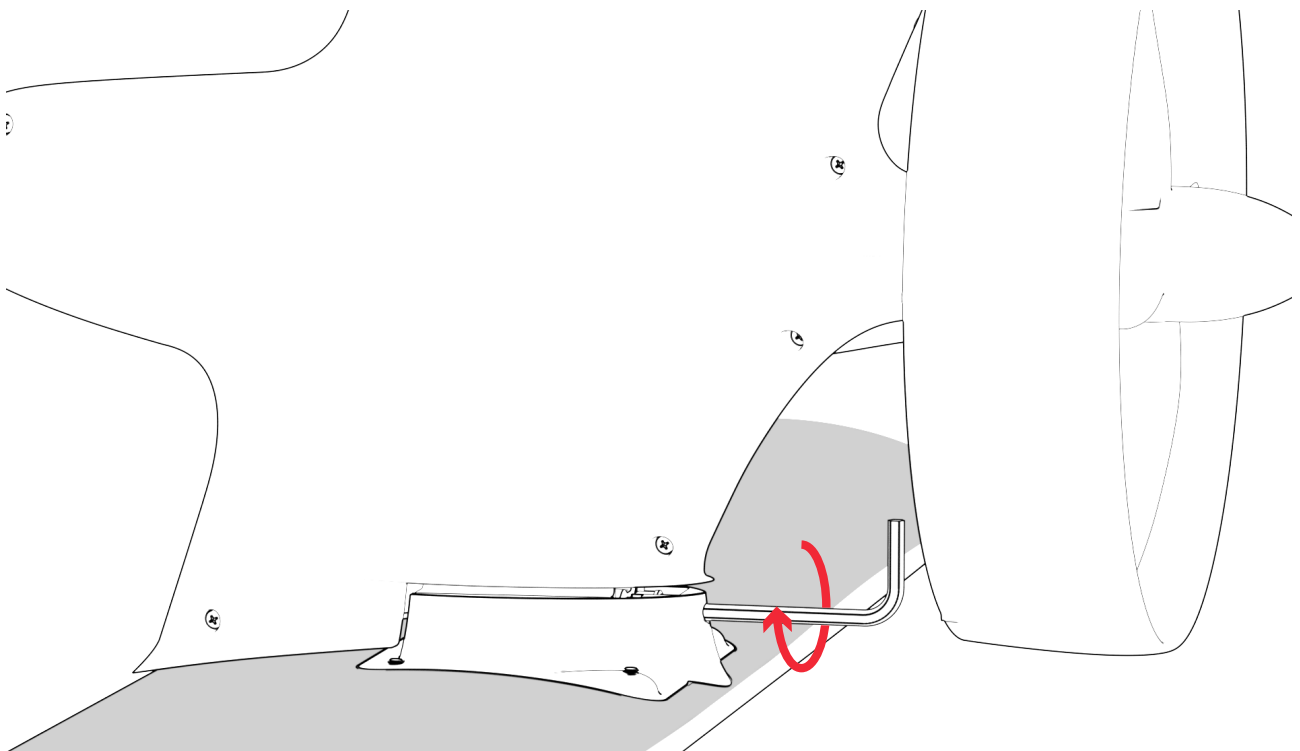

4. Tighten firmly and wobble the drivetrain to check that there is no movement in this connection.

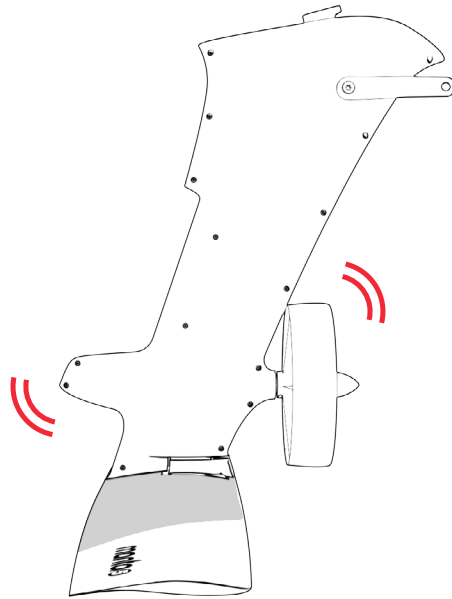

- i** You can allow the drivetrain to lean forward on the propeller shroud on flat firm ground, i.e. not sand or mud.

4.5 ATTACH CHASSIS TO DRIVETRAIN

1. **Make sure red knob located in the rear of the battery tub is pulled forward.** Align the chassis with the drivetrain, ensuring that there is a flush fit all around the interference. The chassis will rest in place on the drivetrain if connected properly.

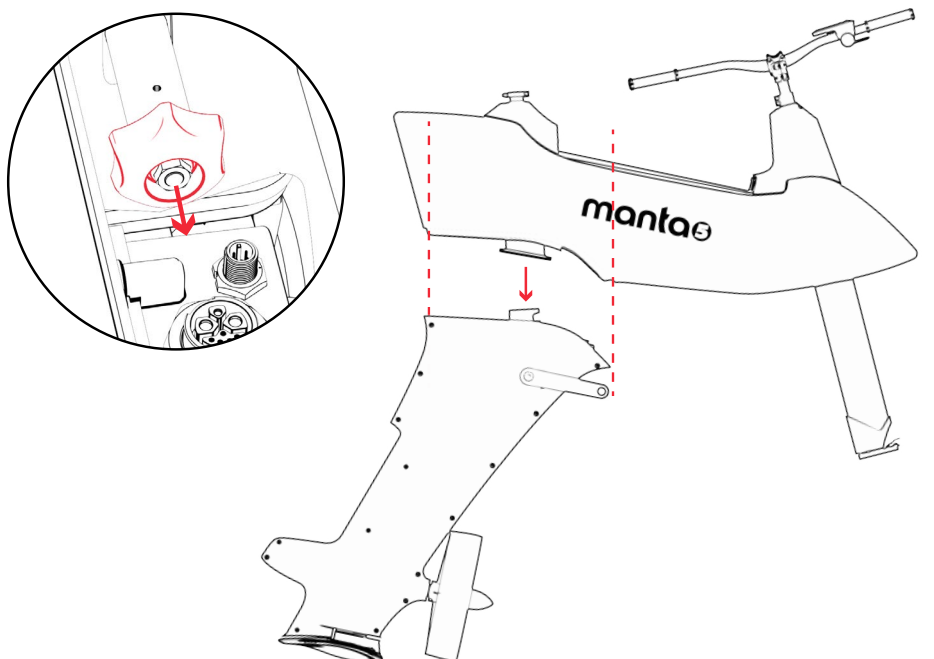

2. Tighten the chassis lock.

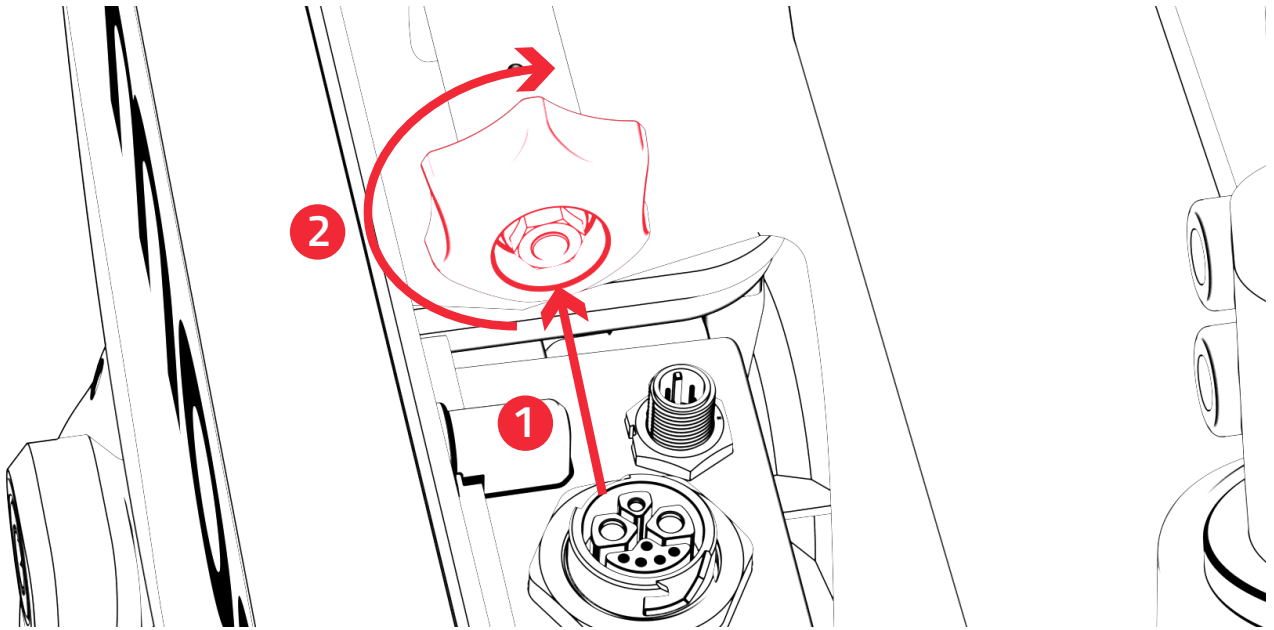

3. Once connected, lift the chassis gently to check that there is no unwanted movement between the chassis and the drivetrain.

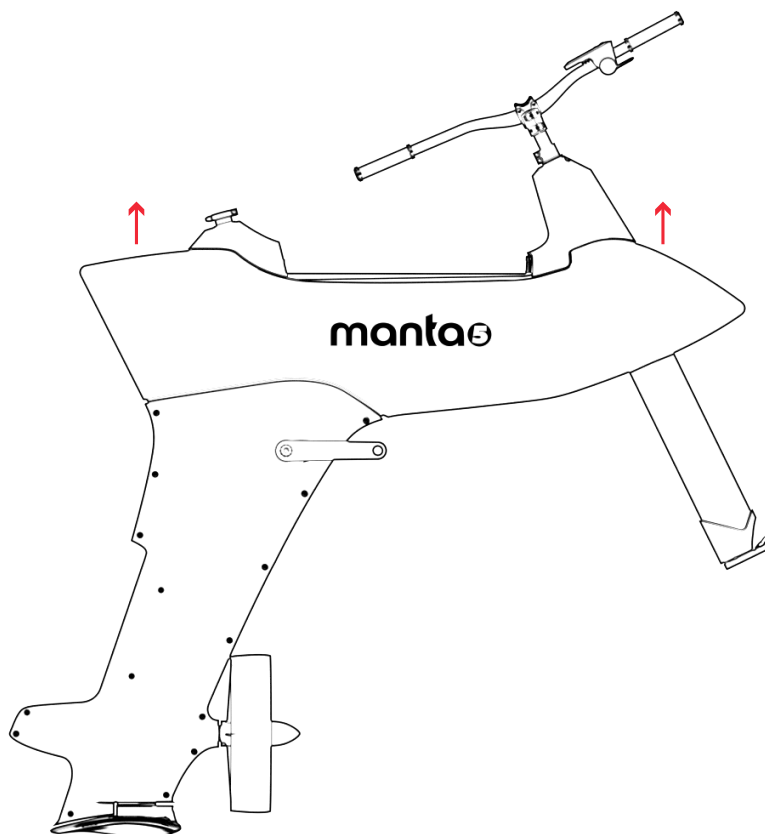

4. Connect the Ride Controller cable to the control box, which is located in front of the chassis lock. Rotate the twist lock to tighten the connection. When tight, pull gently on the cable to ensure that correct connection has been achieved.

! Ensure the Ride Controller cable is unplugged before attempting to disconnect the drivetrain.

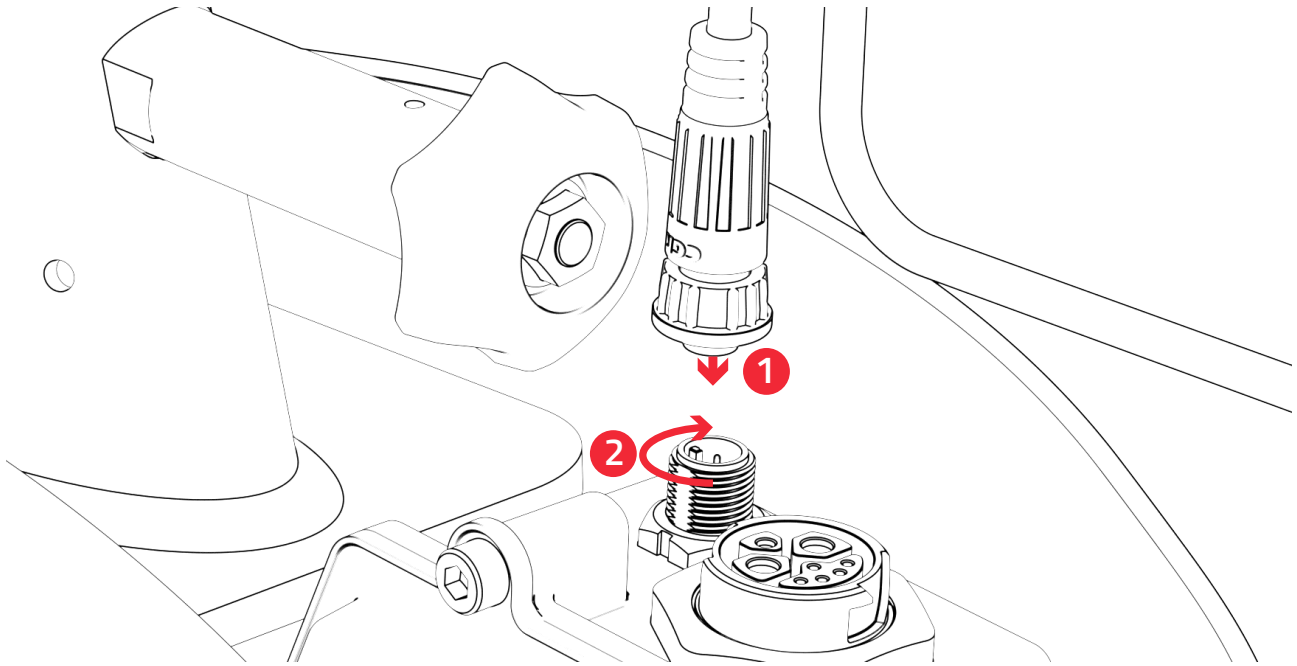

4.6 ATTACH TILLER TO CHASSIS

1. Holding the quick connect connection of the tiller, align and slide the connection into the slot until the latch clicks into place.

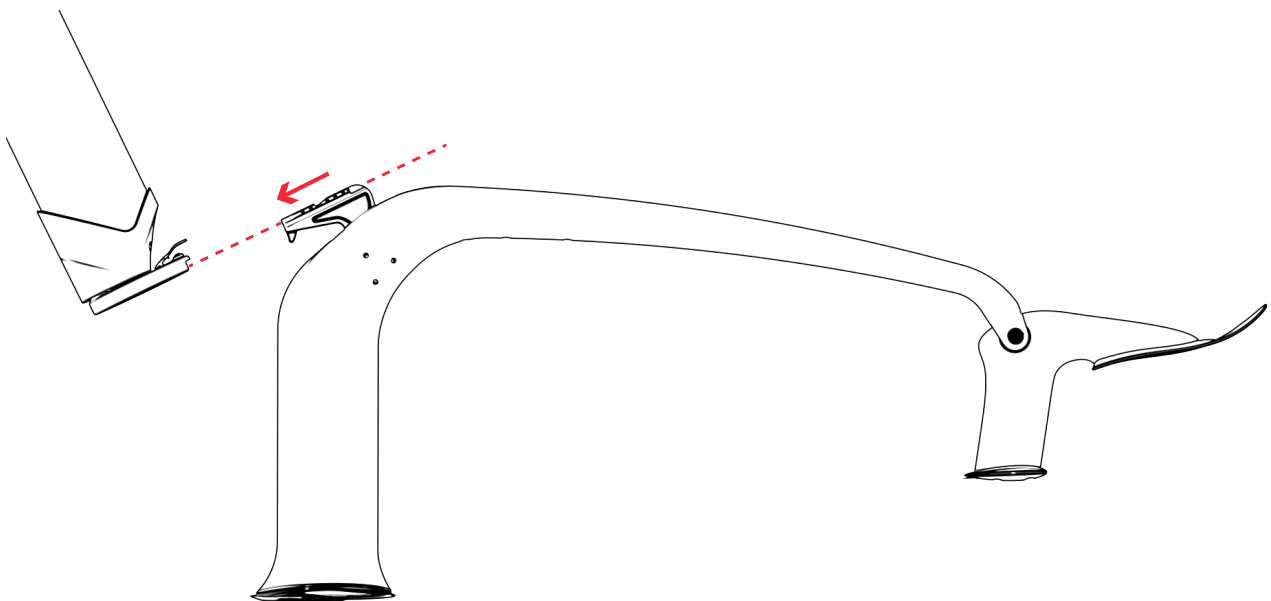

2. There will be an audible click when the tiller is connected correctly, and it should be firmly held in place.

i For attaching and detaching the tiller, ensure that you are holding the tiller quick connect. If you simply hold the tiller, the quick connect may jam and it will make attaching and detaching the tiller more difficult.

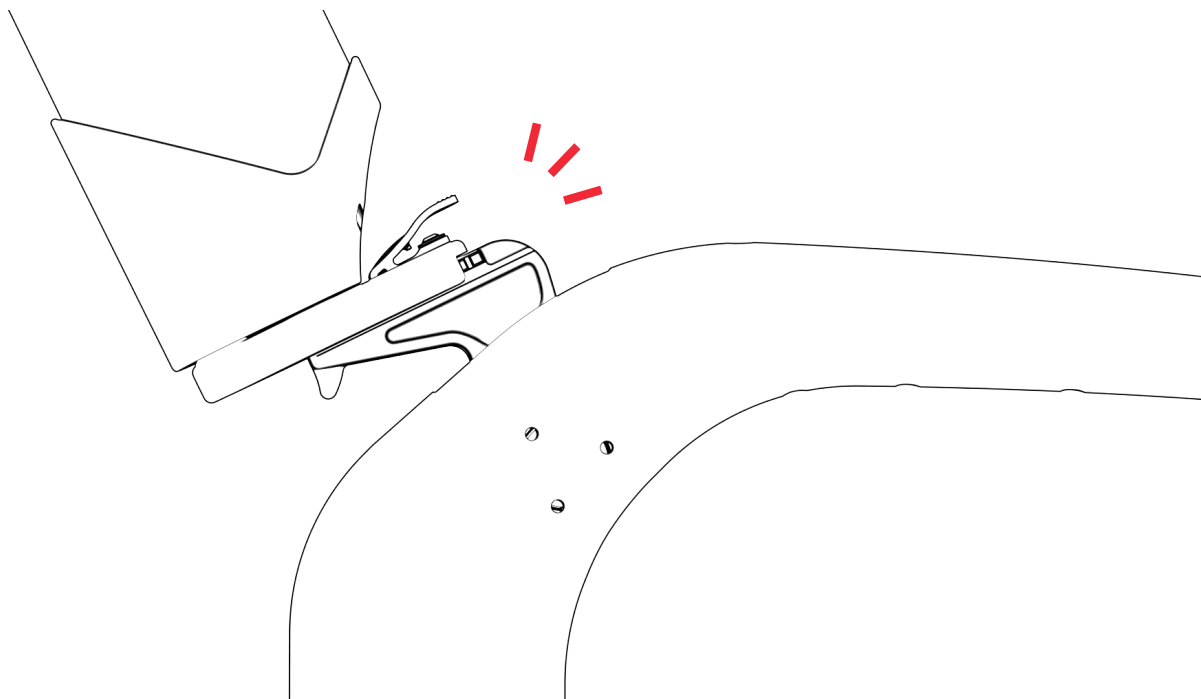

4.7 MOUNT THE SEAT POST

1. Open the latch of the seat post connection, slide the seat post into the chassis and straighten it so that it aligns with the length of the chassis.

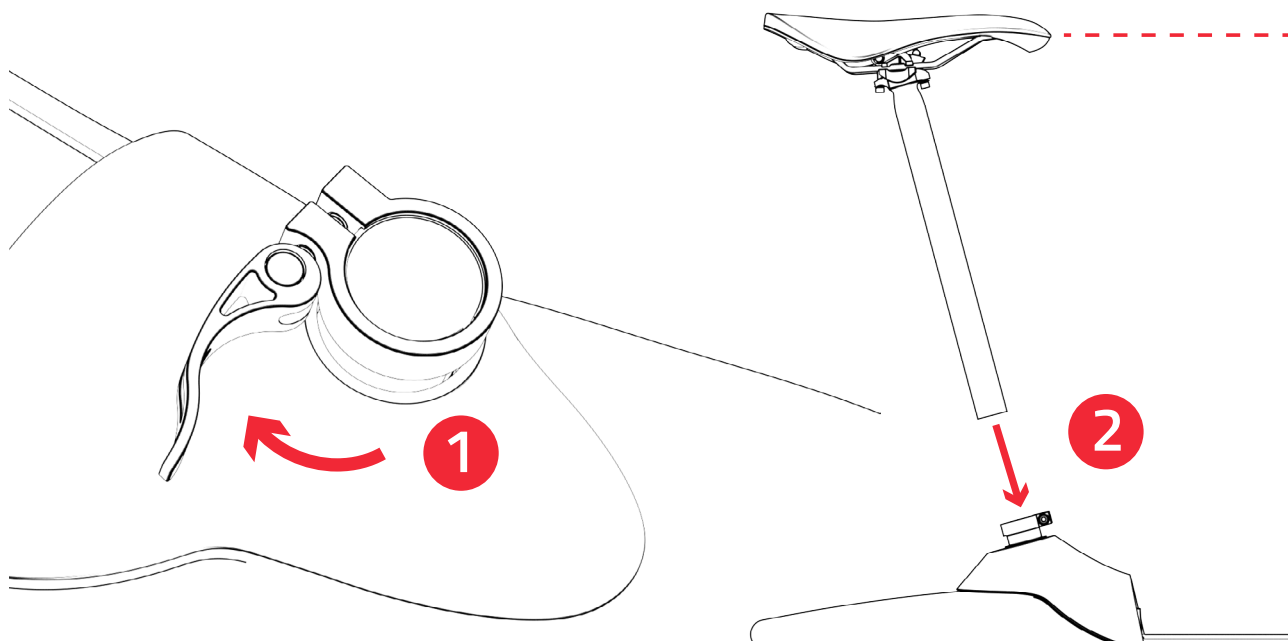

2. Adjust the height of the seat to your preference.

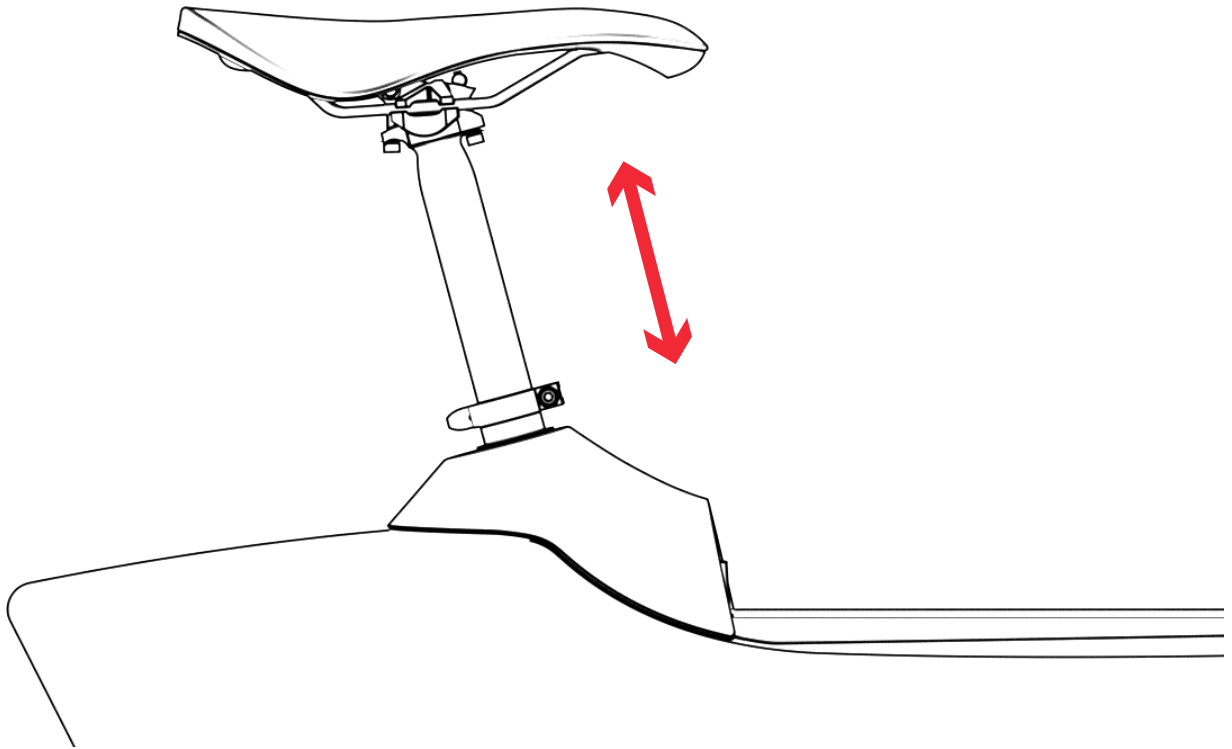

3. Lock the seat post by folding the latch of the seat post connection inwards. This should be firm, and the saddle should not be able to move.

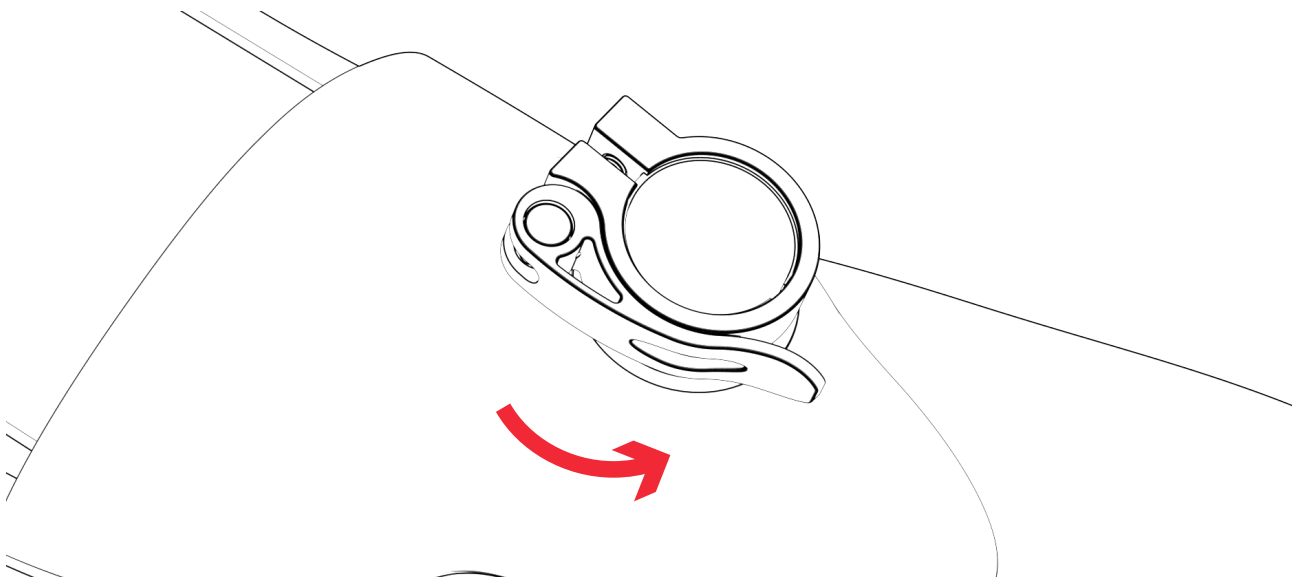

- ⓘ Tighten the seat post connection with a 4mm Allen key if necessary.
- ⓘ For optimal adjustment, the saddle can be moved forwards or rearwards to accommodate for shorter or taller riders.

4.8 ATTACH THE PEDALS

1. Identify which pedal is the 'Left' and which pedal is the 'Right'. The pedals should have a small 'L' or 'R' on the pedal to help with this identification.

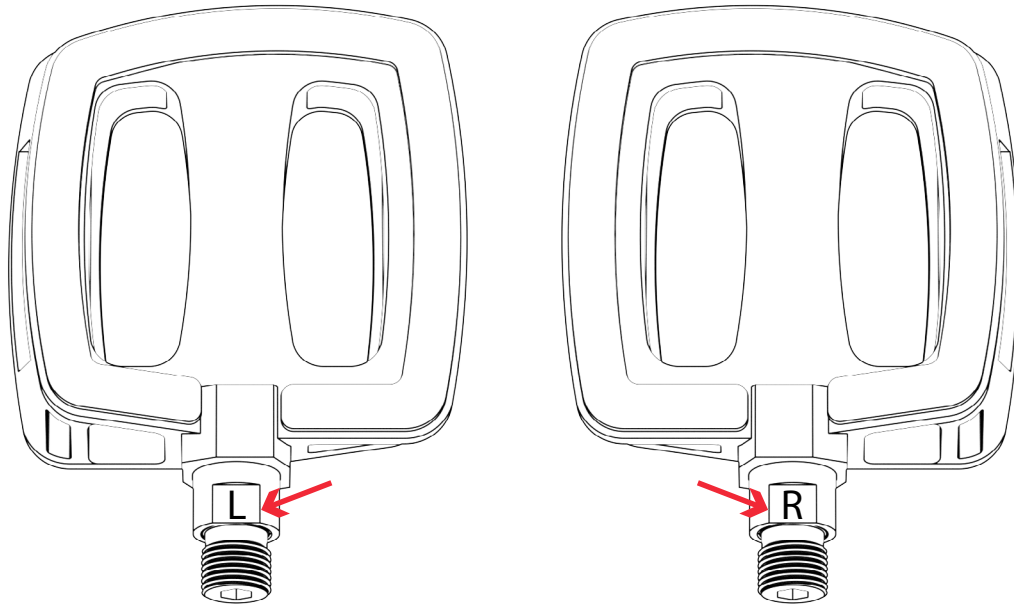

2. Screw the left pedal into the left crank and the right pedal into the right crank. The left pedal will have a left-handed thread, so you will need to turn it anti-clockwise to tighten.

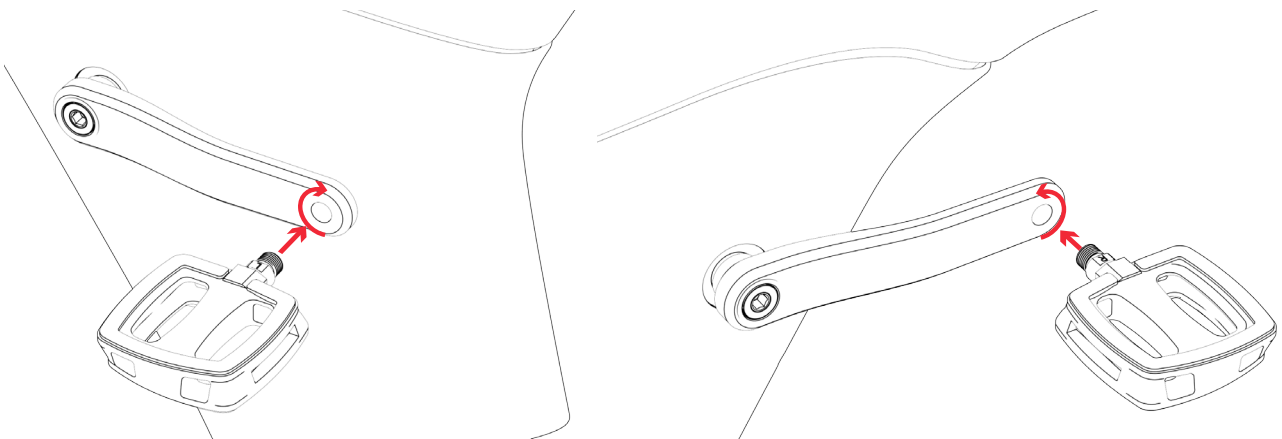

3. Using the 6mm Allen key provided, tighten the pedals firmly.

i The pedals supplied could be slightly different from these instruction, as well as the L (left) and R(right) identification position.

4.9 ADJUST THE HANDLEBARS

The handlebars will come assembled to the steering shaft but will need straightening.

1. Using the 4mm Allen key, loosen the two screws on the stem.

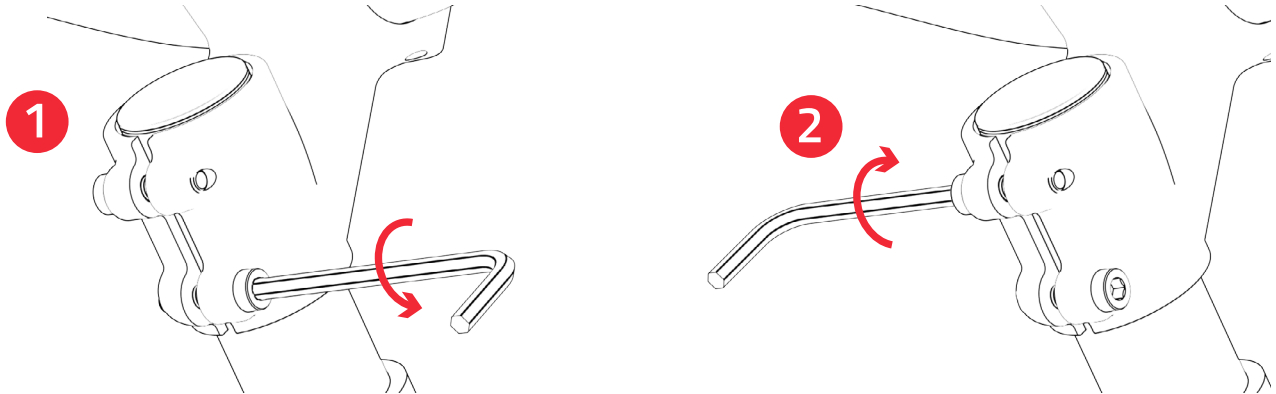

2. Align the tiller so that it is pointing as straight as possible.

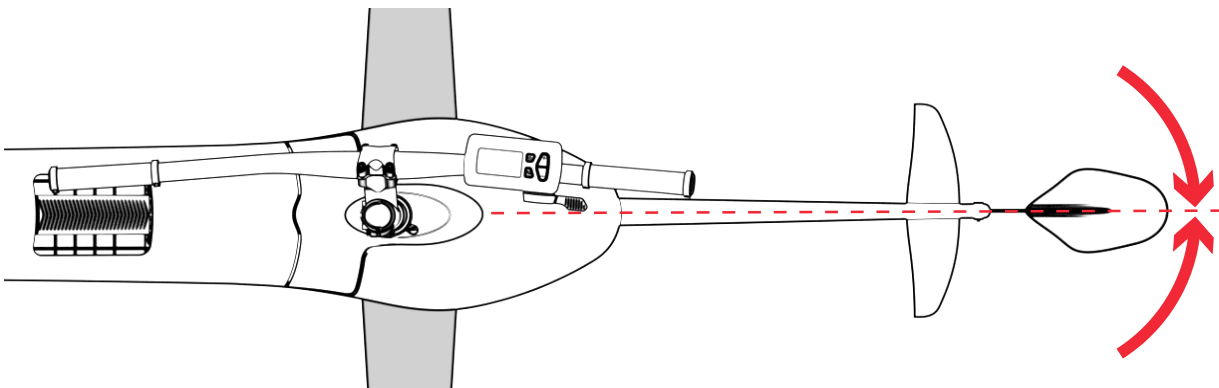

3. Align the handlebars so that they are perpendicular to the direction of the tiller.

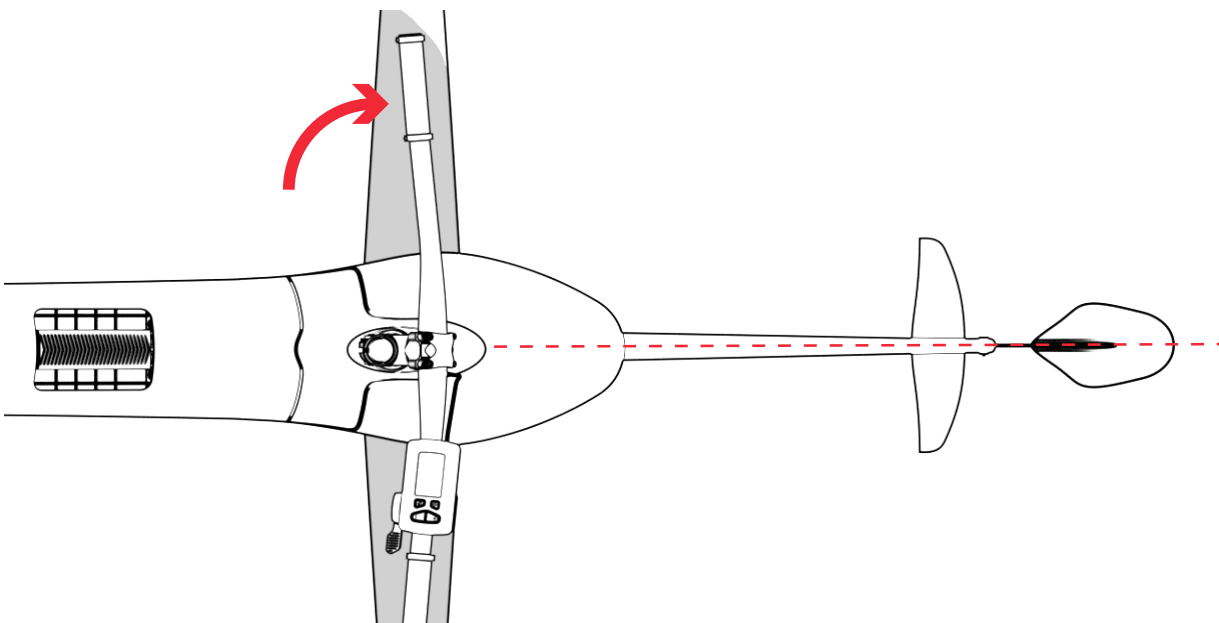

4. With the top of the stem flush with the steering shaft, firmly tighten the two screws on the stem.

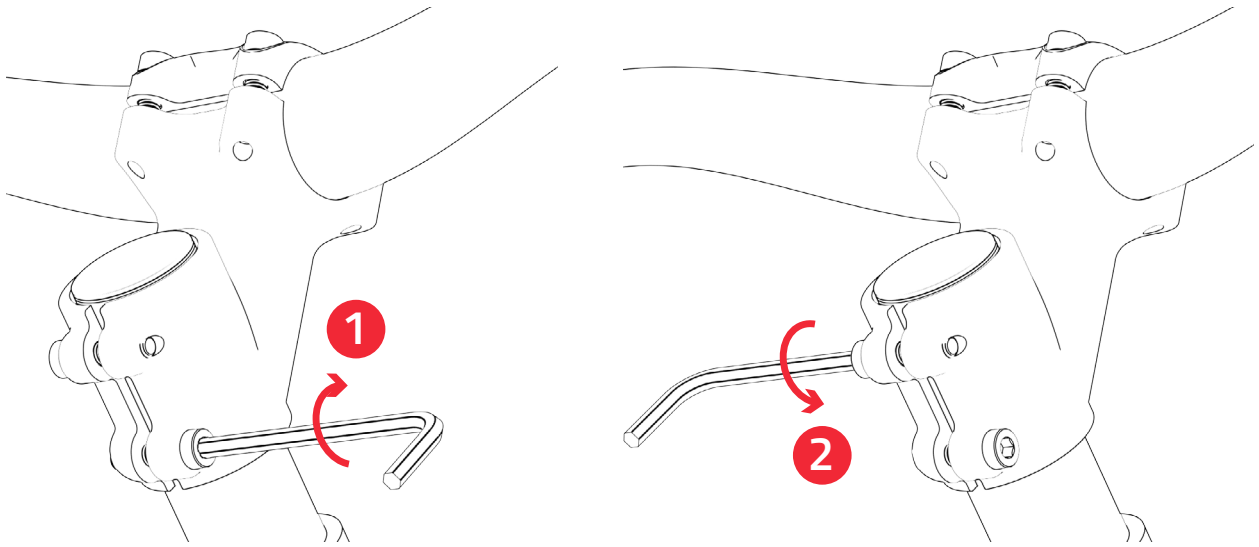

5. Tighten the ride controller and stem using the 3mm Allen key.

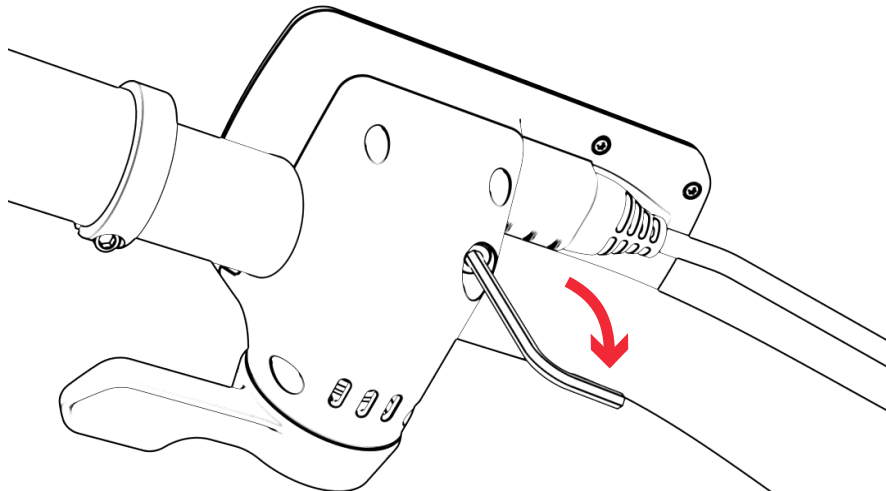

4.10 CONNECT THE BATTERY TO THE CHASSIS

1. Before connecting the battery cables to the battery, inspect the cables for any damage or water on the connection point. The connectors must be dry, free of any corrosion and the cables must not have any damage.

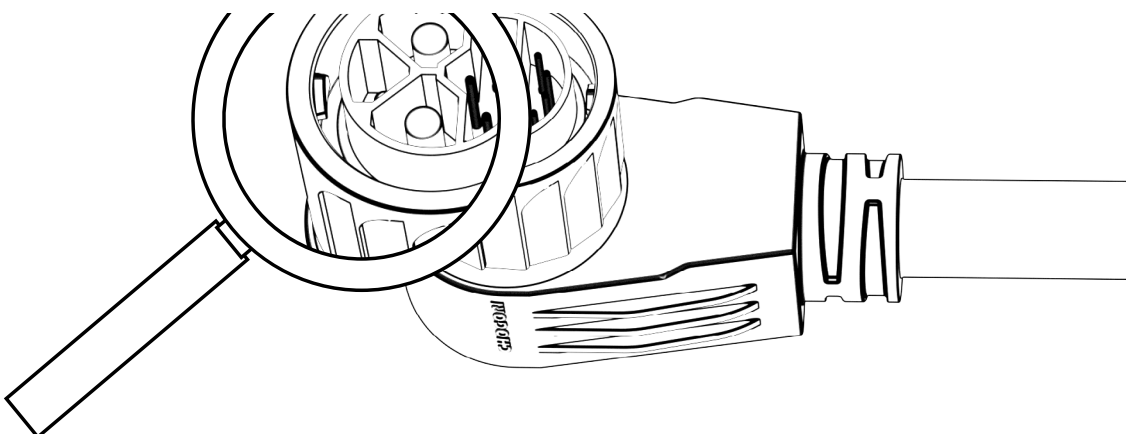

2. Connect the battery cable to the control box. Push down firmly until an audible 'click' is heard. Pull gently on the battery cable connector to ensure that correct connection has been achieved.

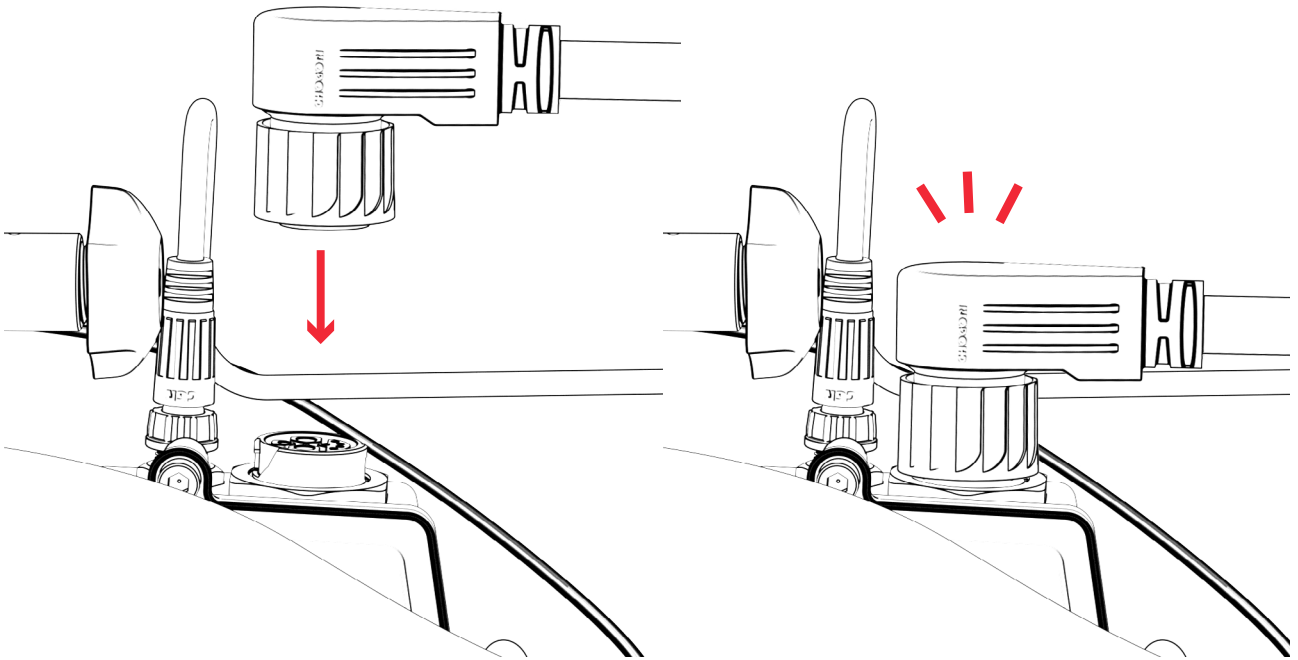

3. Once the battery cable is connected, the screen should display the battery level.

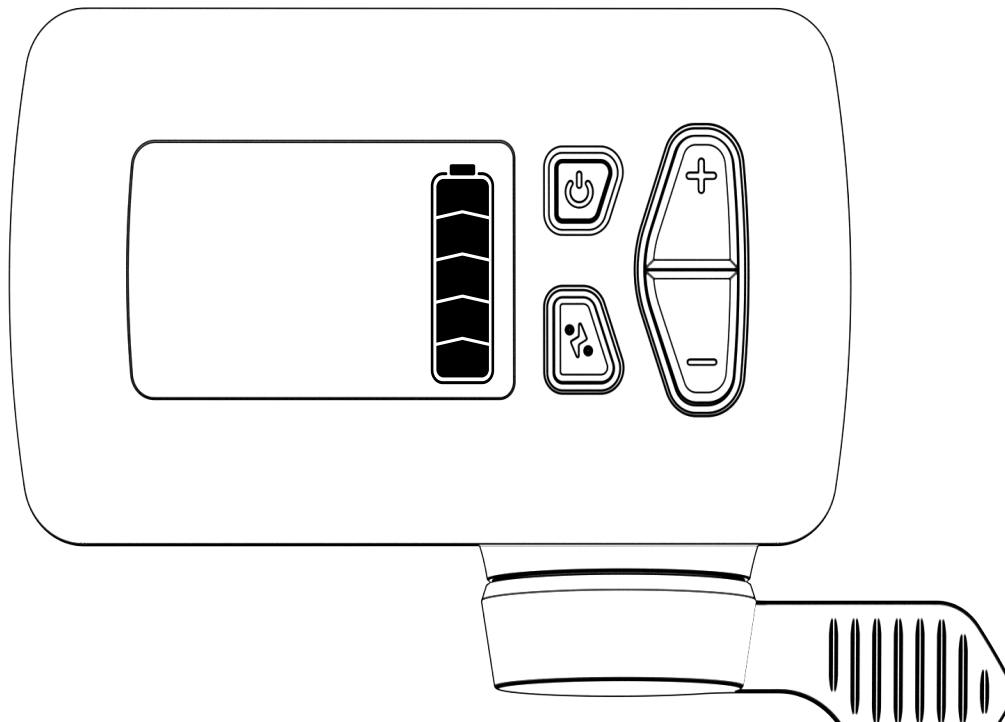

4. Insert the battery into the chassis, with the arrow illustrations on the handle pointing towards the front of the bike.

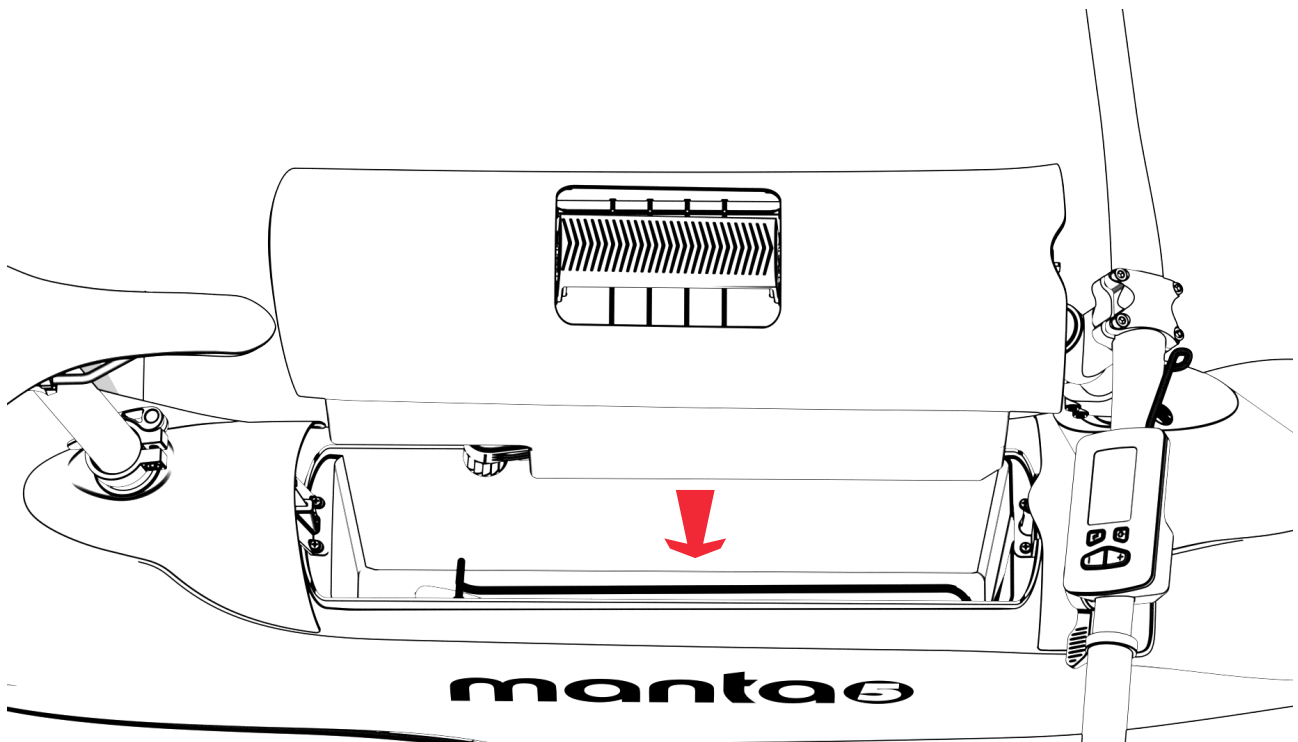

5. Ensuring that the battery is flush with the chassis, push the handle down firmly, locking the battery into place. An audible 'click' can be heard once connected correctly, and the handle should be flush with the battery. Your SL3 is now ready to enter the water.

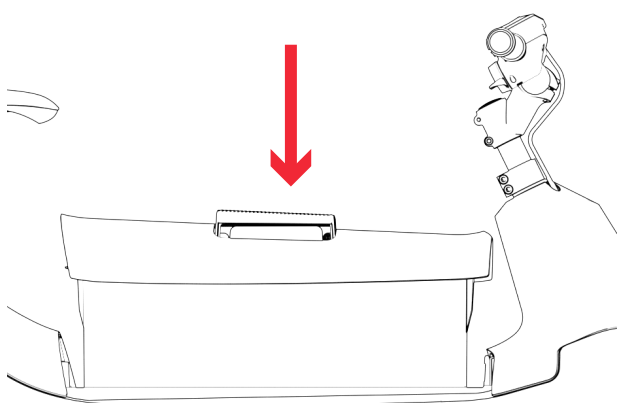

manta 5

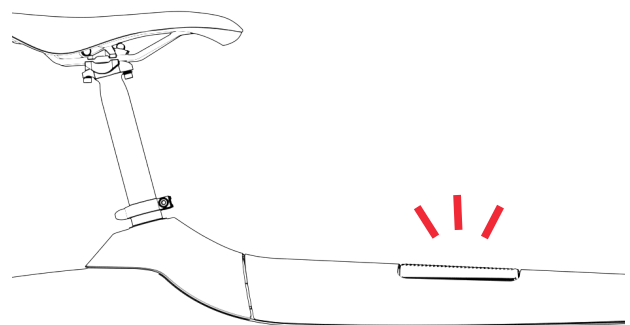

manta 5



5. BEFORE YOU RIDE

WARNING

- **RIDING CONDITIONS:** The rider should ride only in water conditions that do not exceed the skills of the rider and remain within reasonable swimming distance to the shore or a support vessel at all times.
- **RIDING CONDITIONS:** The rider should never ride when there is an offshore wind or current unless they have a support vessel.
- **SUBMERGED OBJECTS:** The rider should check the riding area and attempt to identify any submerged objects which could cause a collision.

CAUTION

- **Local Regulations:** The rider should research, understand, and abide by their local maritime regulations at all times.
- **Riding Depth:** The rider should only ride in water with a depth of more than 2 meters.

5.1 RECOMMENDED TRANSPORTATION



The Hydrofoiler SL3 has been designed to easily disassemble the various parts of the bike easily and quickly for transport in a vehicle. In some vehicles the rear seats may require to be folded down. Unless there is already soft material in the rear of the vehicle, this is recommended to reduce scratches and damage to the Hydrofoiler SL3. The rider should attempt to secure the parts of the Hydrofoiler SL3 to the best of their ability before driving to avoid movement of parts during transport.

5.2 LOCATION SELECTION

Location selection is key for maximum fun and safety when riding your Hydrofoiler. It is worth spending some time finding a suitable ride location before attempting to ride. Below we have some recommendations for selecting the best ride location:

5.2.1 Easy access into the water

Easy access to the water, and into the water are key in getting your Hydrofoiler from your house, storage facility, or vehicle before your ride. Transport the Hydrofoiler disassembled to the water's edge where possible. Therefore, if you have the option of a launch location that has a car park closer to the beach, this would make it easier.

5.2.2 Large enough area to practice turning

Manta5 recommends a large body of water to begin learning to ride, with enough room to conduct wide

turns that are typical of a novice rider. This will help protect you and your new Hydrofoiler from injury or damage.

5.2.3 Calm beach

The recommended ideal launching location is a calm beach. For beginner riders, finding your balance and the stability of the bike when launching and riding is critical to fast progression. This is most effectively done in calm water, free of current and waves.

5.2.4 Deep enough to launch

Hydrofoils should never come in contact with anything below the surface of the water. This includes during launching, which is when the foils are the deepest. However, the rider should always ride in water that is deep enough to launch from to ensure that they can continue riding if they were to fall off. Therefore, the minimum water depth for riding is 2.0 meters (6.5 ft).

5.2.5 Under supervision

For beginner riders, we recommend that someone be with you to supervise until you are a confident rider. As with all outdoor sports, foil biking can also be the victim of fast changes in the weather.

5.2.6 Local rules and regulations

It is the responsibility of the rider to research and understand the local rules and regulations for the body of water they intend to use their Hydrofoiler on. This also includes, but not limited to, speed limits, required safety equipment, and restricted navigation zones.

5.3 WATERSIDE ASSEMBLY

5.3.1 Move the modules to waterside separately

Depending on your location, and the access of your location, you may be required to transport the Hydrofoiler to the water from your vehicle, house, or storage location. When the Hydrofoiler is fully assembled, we recommend that 2 people do this to help avoid injury to themselves or damage to the bike. However, with the modularity of the SL3 and quick connection points we recommend that transport to the waterside is done in separate modules and only fully assembled near the water line.

5.3.2 Set up rear foil on even ground



The first step to the waterside assembly is finding a flat place to lay the rear foil. This should be as close to the water as possible, on a flat, even surface, free of rocks or other sharp objects that could damage the foil.

Attach the Drivetrain

With the rear foil placed flat on the ground, slide the bayonet upright of the drivetrain into the rear foil shoe and tighten using the 6mm Allen key as explained in Section 4.4, page 20. Once assembled, you can gently lean the drivetrain forwards onto the propeller shroud. The propeller shroud has been designed to be able to take this weight, but selection of a flat surface is important to avoid the drivetrain falling over when left resting like this.



5.3.3 Place the assembled tiller in front of drivetrain

Place the tiller section 1.5-2m in front of the drivetrain. This should be roughly where the tiller will rest when attached to the chassis.



5.3.4 Attach the chassis

Attach the chassis to the drivetrain as explained in the initial assembly (Section 4.5, page 22).



5.3.5 Attach tiller

Attach the tiller using the tiller quick connection as explained in Section 4.6, page 24.



5.3.6 Connect battery to chassis

Before connecting the battery, visually inspect the battery for damage, such as cracks or loose screws that could have occurred during transportation. Inspect the cables for any damage or water on the connectors. The connectors must be dry, free of any corrosion and the cables must not have any damage. Attach the battery to the chassis as explained in Section 4.10, page 29.





5.4 PRE-FLIGHT CHECKS

Final pre-ride checks that need to be conducted before riding.

SAFETY CHECKS		HYDROFOILER SL3 CHECKS	
Am I wearing the required personal safety equipment?	<input type="checkbox"/>	Check that the battery housing free of damage	<input type="checkbox"/>
What is the wind, tide and water conditions currently and forecasted? Am I confident in riding in these conditions? If in doubt, don't go out.	<input type="checkbox"/>	Check that the chassis-drivetrain connection is secure and tight.	<input type="checkbox"/>
Are there any submerged objects in the water that could be hazardous?	<input type="checkbox"/>	Check that the Hydropack battery and ride controller cables are connected properly.	<input type="checkbox"/>
Are there any other watercraft or swimmers in the area that could be hazardous?	<input type="checkbox"/>	Check the battery level and that no errors are present.	<input type="checkbox"/>
What is my Plan B if I am unable to return to shore?	<input type="checkbox"/>	Check that all connections are secure and tight, as per the assembly instructions.	<input type="checkbox"/>
Have I told someone where I am riding and when I am scheduled to return?	<input type="checkbox"/>	Perform a function check - activate motor and engage throttle (deactivate before transporting to water).	<input type="checkbox"/>



6. RIDING INSTRUCTIONS

WARNING

- **INSTRUCTIONAL RESOURCES:** Manta5 recommends that all manuals, instructions, and other educational resources provided should be read and understood before attempting to use the Hydrofoiler SL3.
- **PERSONAL PROTECTIVE EQUIPMENT:** Riders should always wear a suitable personal flotation device that is approved by the relevant local regulating body. The rider should also ride with a suitable communication device or have supervision from the land. Furthermore, riders are highly recommended to wear aquatic footwear, swimwear, and a helmet (at the rider's discretion) to protect them from potential injury.

CAUTION

- **Losing Control:** If the rider loses control of the bike, they should push off the pedals and fall away from the bike.
- **Safe Riding Practices:** Riders should maintain safe speeds for the conditions and keep a safe distance from other people, objects and other watercraft. The rider should take early action to avoid collisions and remember that the Hydrofoiler does not have brakes like a conventional bicycle and foils that protrude 1m each side.

6.1 RIDE CONTROLLER INTRODUCTION

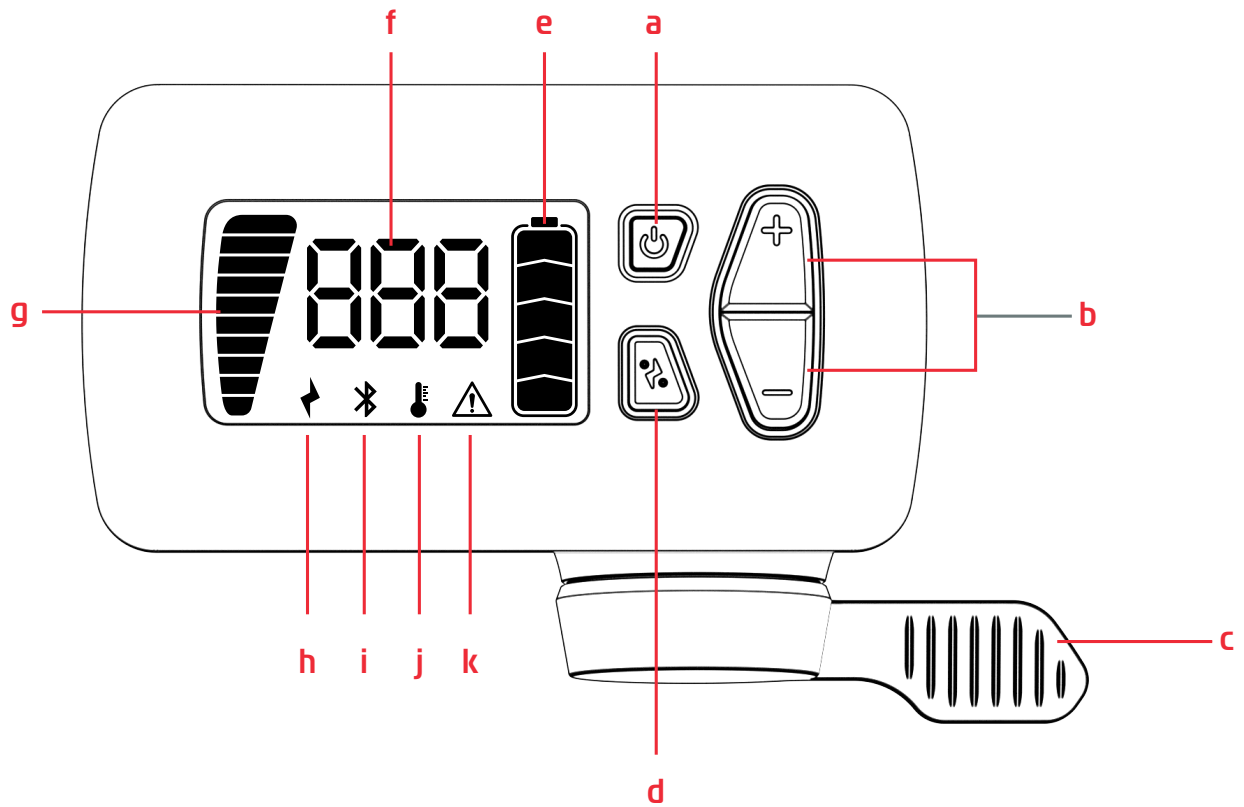

- a. Power button
- b. Rocker buttons (+/-)
- c. Throttle lever
- d. Activate motor button
- e. Battery state of charge
- f. Throttle gauge
- g. Assistance level (0-10)
- h. Motor active symbol
- i. Bluetooth connection
- j. Temperature warning
- k. Error/ fault warning

a. Power Button

The Power Button is used for Powering On the Hydrofoiler SL3, as explained in Section 6.3, page 44.

b. Rocker Buttons (+/-)

The Rocker Buttons are used to change the level of electrical assistance. The '+' increases the assistance power provided by the battery and the '-' decreases the assistance power.

c. Throttle Lever

The Throttle lever is used for launching and electric only foiling (no pedalling). Similar to an electric scooter, the amount you push the Throttle Lever corresponds to the amount of power applied.

d. Activate Motor Button

The Activation Motor Button can be used to activate the motor of the SL3 for launching (Section 6.6.4, page 47) and for deactivating the motor when returning to land (Section 6.9, page 52). This is displayed by the Motor Activate Symbol (h).

e. Battery State of Charge

The battery state of charge is found on the right-hand side of the screen and displays battery level in 5 increments of 20% charge each.

f. Throttle Gauge

Indicates the position of the throttle from 0 to 100.

g. Assistance Level (0-10)

The Assistance Level is found on the left-hand side of the screen and displays the level of assistance that the battery power will provide when pedalling. This is displayed in 10 assistance levels and is changed using the Rocker Buttons (b).

h. Motor Activate Symbol

The Motor Activate Symbol is displayed along the bottom of the screen in the shape of the lightning bolt. This indicates whether the motor is active or not and is controlled by the Motor Activate Button (d).

i. Bluetooth® Connection

The Bluetooth® Connection Symbol is displayed along the bottom of the screen in the shape of the Bluetooth® Logo. This indicates the connection of the Ride Controller.

j. Temperature Warning

The Temperature Warning Symbol appears along the bottom of the screen in the shape of a thermometer when the Hydrofoiler SL3 overheats. If you encounter the Temperature Warning, cease riding and allow the Hydrofoiler SL3 to cool down.

k. Error/Fault Warning

The Error/Fault Warning Symbol appears along the bottom of the screen in the shape of a warning signal. This indicates that there is an error in the SL3 that needs attention. If you encounter the Error/Fault Warning do not ride and contact your Authorised Reseller or a Manta5 Service Agent.

6.2 USING THE RIDE CONTROLLER

6.2.1 Using the throttle

The new throttle not only makes launching easy, but it also offers riders the option of not pedalling. If you would like a break from pedalling, simply apply the throttle and stop pedalling. Please note that using the throttle alone will reduce your battery range.

6.2.2 Changing levels of assistance

The Hydrofoiler SL3 allows the rider to combine physical power output from pedalling with the electrical power provided by the electric motor. Riders can toggle between 10 levels of electrical assistance while riding. As the electrical assistance is increased, it will become easier for the rider, but the ride time will decrease.

The level of assistance can be changed with the Rocker Buttons, and the current Assistance Level can be viewed on the screen of the Ride Controller.

6.2.3 Monitoring battery level

When riding, the electrical energy provided by the battery will gradually begin to decrease. Multiple factors impact this such as rider weight, temperature, battery health, water conditions, etc. However,

the main factor is the level of electrical assistance.

Riders should continuously monitor the battery level. This can be found on the screen of the Ride Controller. The battery level is displayed in 5 increments of 20% charge, respectively. Once 20% battery level or less remains, the battery will begin to flash, indicating time to return to shore. To increase the riding range, reduce the level of electric assistance (Section 6.2.2, page 43).

6.3 POWERING ON - STANDBY MODE

1. Power the Ride Controller by pressing and holding the POWER Button for 3 seconds. The screen will show "ON".

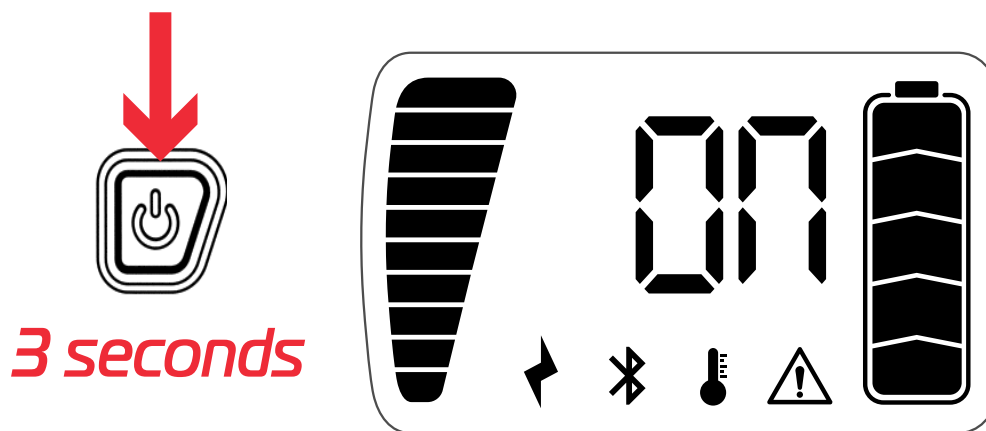

2. Review the screen for any potential errors. If an error appears, please refer to the SL3 Ride Controller Errors (Section 6.1, page 41).

6.4 ENGAGE MOTOR

ⓘ While in standby mode the motor is not active and needs to be engaged to start.

The motor can be activated in one of two ways.

- Rotate the pedals one full rotation (360 degrees) or;
- Hold the motor activate button for 3 seconds. Either of these methods will activate the motor and allow you to use the throttle and electric assistance.

After a 20 second period of inactivity the motor will automatically deactivate.

⚠ WARNING BEFORE TRANSPORT ENSURE THE MOTOR IS IN STANDBY MODE OR TURNED OFF

6.5 ENTERING THE WATER



- When fully assembled, the Hydrofoiler SL3 is large. The closer you can assemble to the water the better.
- When moving to deeper water it is easier to pull from the tiller as opposed to pushing from the back. The rear foil should already begin to generate some lift to stop the rear foil from dragging on the bottom.

6.6 MOUNTING

Be patient when learning to launch the Hydrofoiler SL3. Take breaks often and enjoy the process of mastering a new skill.

6.6.1 Depth and direction

Once the Hydrofoiler SL3 is in the water, ensure that the water depth is at least 2 meters. Point the SL3 in a safe direction, with at least 100 meters of clear water. We recommend calm waters for new riders for the highest chance of success.

6.6.2 Mounting

Approach from the side and place your hands on the chassis. Push under the water until your arms are fully outstretched, while keeping upright. Change your grip to the handlebars and seat and continue to push the bike down as deep as you can.



PRO TIP: The deeper you can push the Hydrofoiler SL3 below you the better.

6.6.3 Finding your stability

Once you are standing on the pedals, with your hands on the handlebars, it is important to find your

stability. Move your body forwards, backwards, and side to side. This will help you understand the stability of your Hydrofoiler SL3 underwater.



PRO TIP: Spend a few minutes stationary finding your balance underwater before moving to the next step.

6.6.4 Motor activation

Once you have mounted and understand the balance in the water, stand in an upright position and rotate the pedals one full rotation (360 degrees). This will activate the motor and allow you to use the throttle.

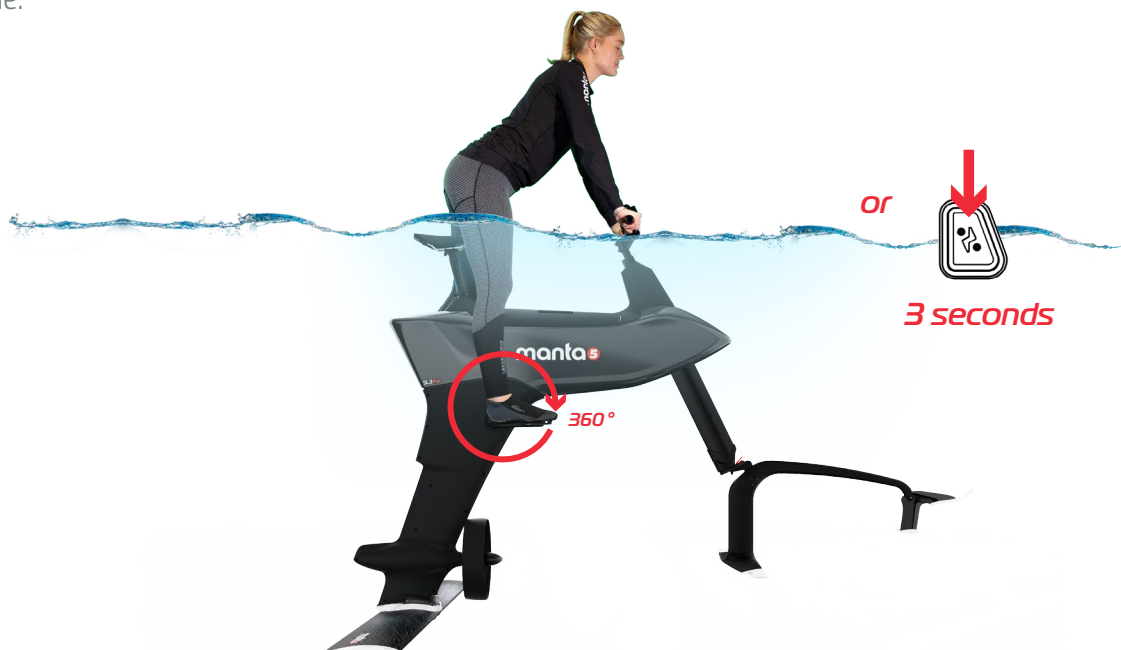

- ⓘ After a period of inactivity in standby mode the Hydrofoiler will automatically turn off. If this happens when attempting to launch, dismount and press the power ON button on the Ride Controller. Re-mount and activate the motor as described above.

6.7 LAUNCHING

6.7.1 Point the nose downwards

Point the nose slightly downwards before applying the throttle. This will allow you to ride submerged for longer, and therefore increase more speed before attempting to launch.



6.7.2 Launch position

For best success during launching, stand in an upright position (not sitting on the saddle), with both of your legs and arms straight and the pedals at even heights. Look forward, and with a straight body, push your hips towards the handlebars to move your weight forwards. You should be in position so you can look down on the top of the front foil.



6.7.3 Take off

Once the SL3 is pointing slightly downwards, gently apply some throttle. The throttle is very sensitive, and similar to an electric scooter, the further it is pushed in, the more power will be applied. Start by only applying a very small amount of throttle.

PRO TIP: Submerged Riding - First time riders are encouraged to get comfortable riding on the bike completely submerged before trying to launch. The faster you can go underwater the better your chance for successful takeoffs



Once you are comfortable riding underwater at almost full power, you can try to launch. Stay in your launch position, apply full power, and then slowly begin leaning back. Lean back until you can feel the SL3 begin to lift you out of the water. Like an aircraft on a runway, this wants to be smooth and gradual. Hold full power and your body position until you are completely above the water, and you begin foiling.



6.7.4 Pedalling

Congratulations! You are now foiling. To transition to your riding position, sit down on the saddle, start pedalling, and let go of the throttle.



Top three tips for a successful launch:

- Lean forward more as you increase the throttle. Heavier riders should have their whole torso leaning completely over the front of the handlebars.
- A longer runway and maximising speed underwater increase the chances of take-off. Don't try to launch too early.
- Point the nose of the bike slightly downwards before you begin your take off - it helps to prevent stalling.

6.8 TURNING



Once you are up and foiling, learning how to turn is an important next step. This is unlike turning on a normal bicycle and will take some practice to do controlled and consistently.

The SL3 turns using a combination of the roll angle and the direction of the tiller. To carve tight turns you need to shift your weight as well as the direction of the tiller.

Here are some tips for learning to take corners:

6.8.1 Slow down for corners

Reduce throttle, the better you get the faster you can turn.

6.8.2 Leaning into the corner before you start turning

For optimal turning, it is good to let the foil start to roll over before turning the handlebars. This will help with more stable riding. Start leaning in the direction you would like to turn, and then turn the handlebars once the SL3 has started to roll in the desired direction.

6.8.3 Leaning out of the corner

Once the Hydrofoiler SL3 has started to roll in the direction you would like to go, you will need to lean out of the corner to prevent from rolling completely over and falling off. Do this by leaning your body into the other direction to stabilise.

6.9 RETURNING TO LAND

When returning to land, it is important to stop foiling before water depth reaches less than 2 meters. This will eliminate the risk of coming into contact with the bottom or submerged objects with the foils or the tiller.

6.10 POWERING OFF

Power OFF the Ride Controller by pressing and holding the POWER Button for 3 seconds. The screen will turn off and only show the battery level until the battery is disconnected. The rider must Power OFF before attempting to remove the battery.

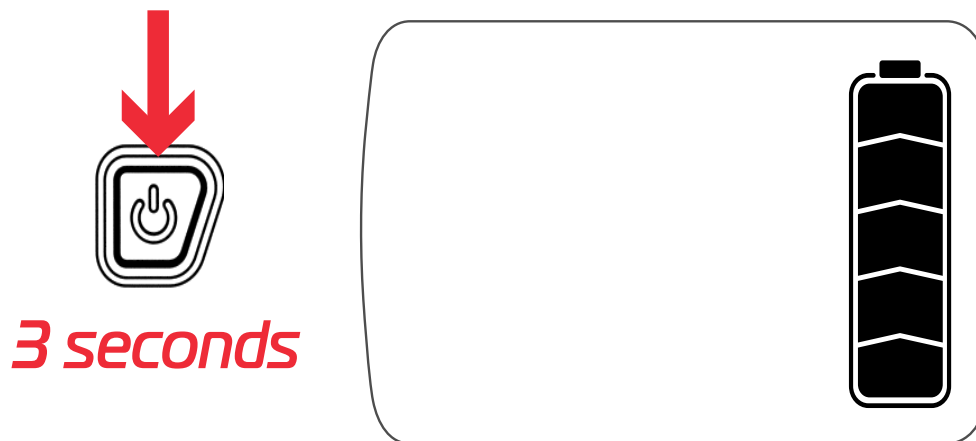



7. MAINTENANCE

WARNING

- **REMOVE BATTERY:** Always remove the Hydropack battery from the Hydrofoiler SL3 before all maintenance.

NOTICE

- **Approved Repair:** Batteries, motors, and gearboxes cannot be repaired by the user and must be replaced or sent to a Manta5 approved service centre for repair. Contact the Manta5 Reseller you purchased your Hydrofoiler SL3 from for further instruction.
- **Stability:** Make sure that your hydrofoil bike is stationary and stable before commencing adjustments or maintenance.
- **Corrosion:** Products that are not cared for after use in marine environments can lead to accelerated corrosion of exposed parts of your Hydrofoiler.

Manta5 recommends that adjustment and maintenance operations be carried out by the user at regular intervals, aiming for preventive maintenance measures to ensure product longevity.

These instructions are designed to enable adjustment and maintenance to be carried out safely by the user, including the protective measures that should be taken during these operations.

7.1 WASH DOWN WITH FRESH WATER

! NOTICE

- Do not use a high-pressure water jet to clean the Hydrofoiler SL3
- Only fresh water is recommended to wash or clean the Hydrofoiler SL3. Soaps and detergents may unintentionally remove grease or oils from parts. Users who wish to use soaps or detergents to clean their Hydrofoiler do so at their own risk.

a. Connectors

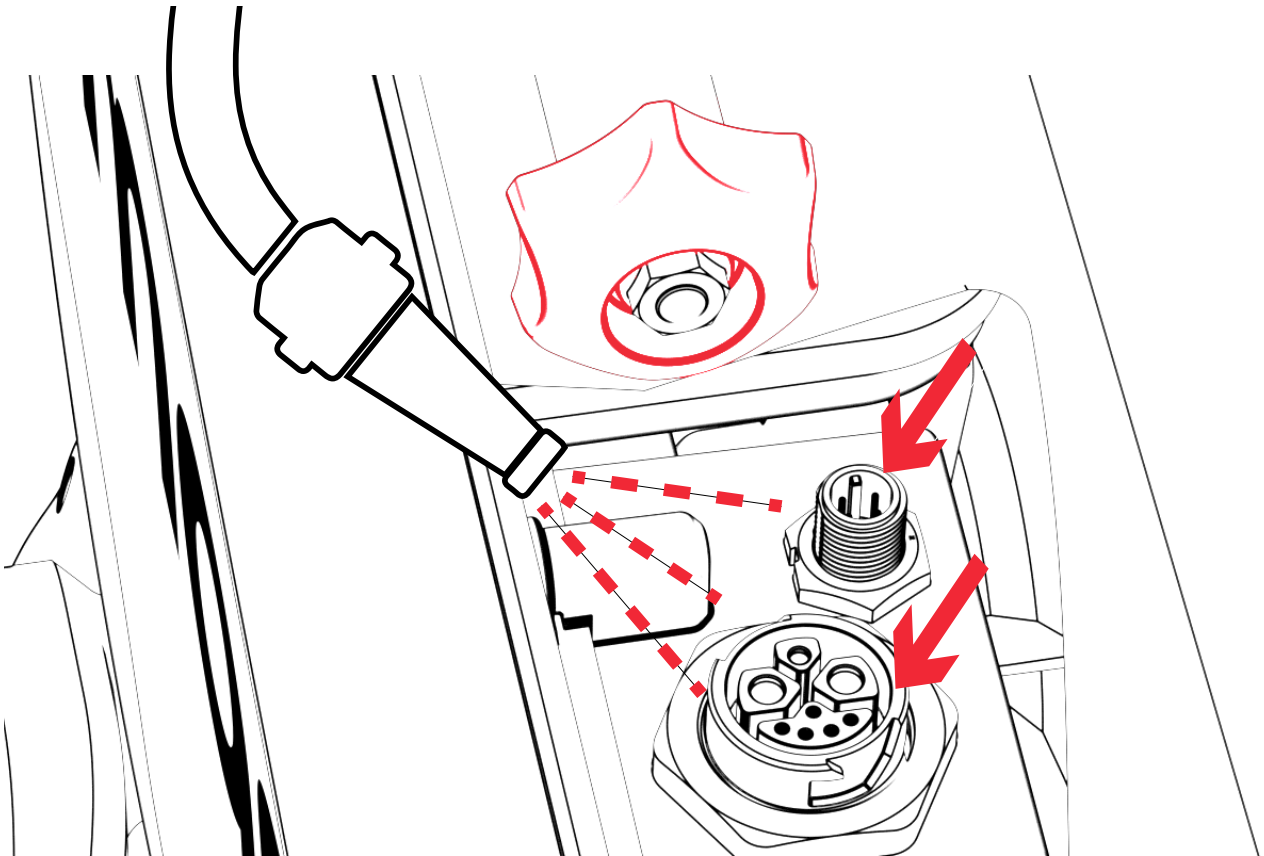

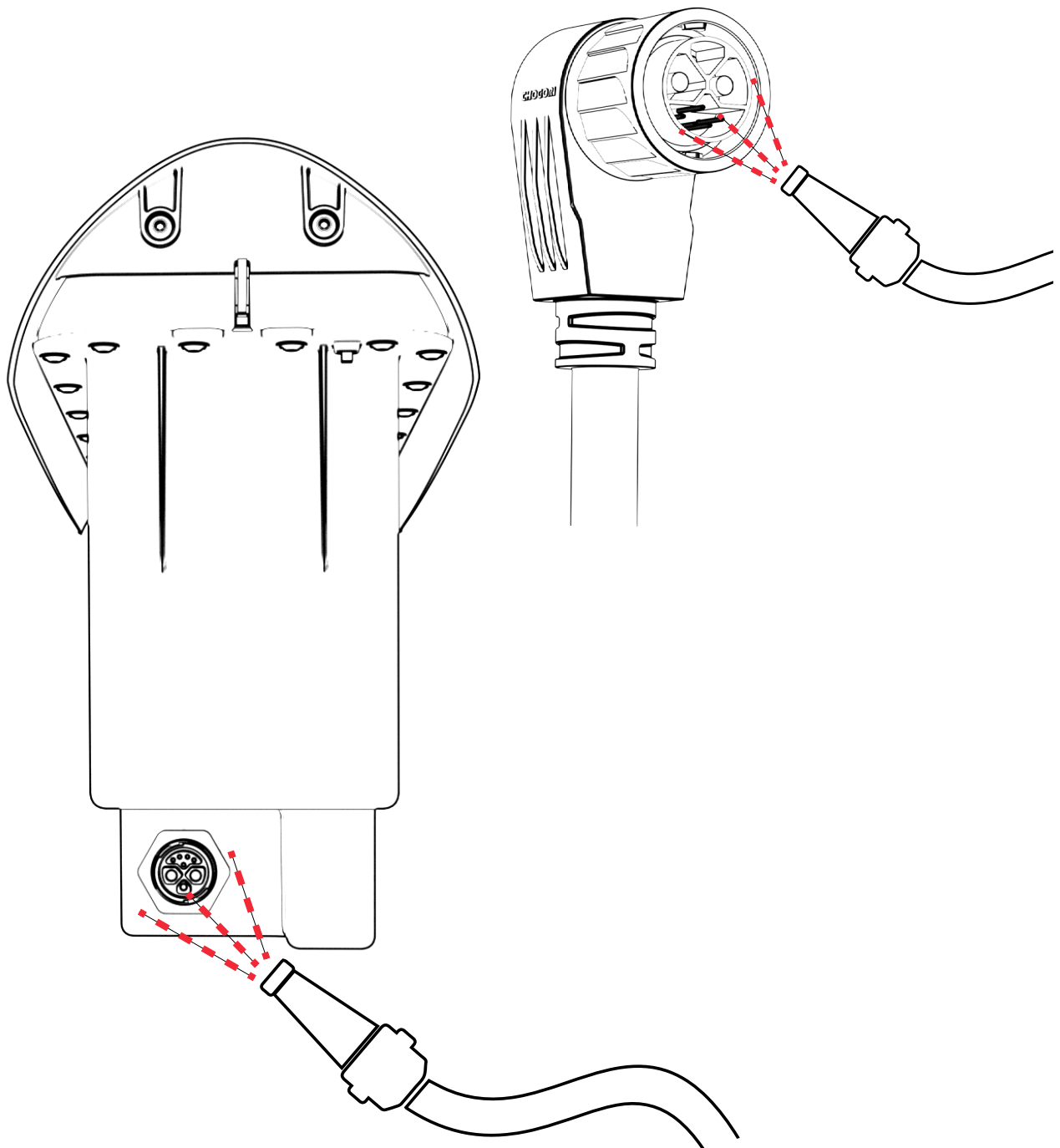

! NOTICE

Where bikes are used in salt water specifically:

- Lightly rinse with fresh water and dry electrical connector contacts on the battery cable, battery, and on top of drivetrain.
- Apply contact lubricant to all these connectors once a month or every few rides.

If you see any sign of corrosion then you should increase the frequency you inspect, clean, and lubricate these connectors.

b. All exterior surfaces

Especially when used in salt water, all exterior surfaces should be washed down thoroughly. Even stainless-steel and aluminium components on the stem and seat post can corrode if not washed after use in salt water.

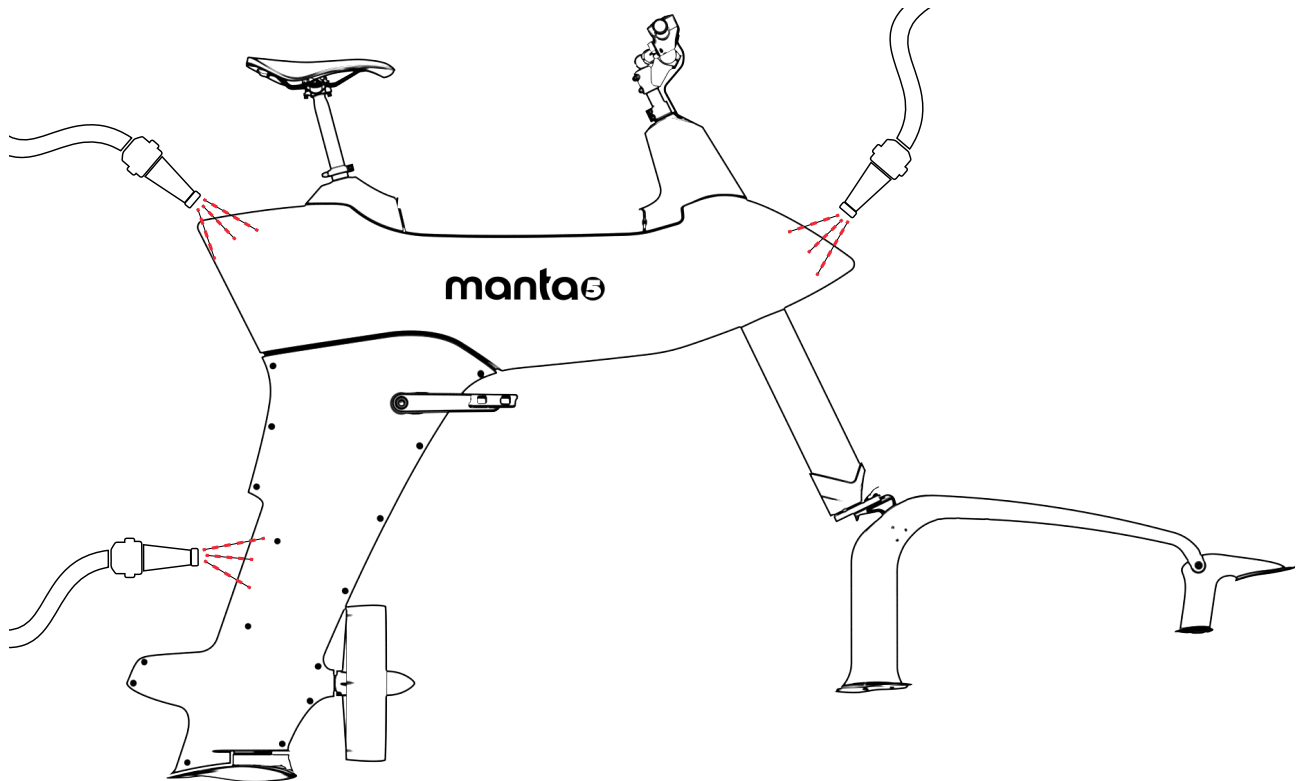

c. Inside the tiller

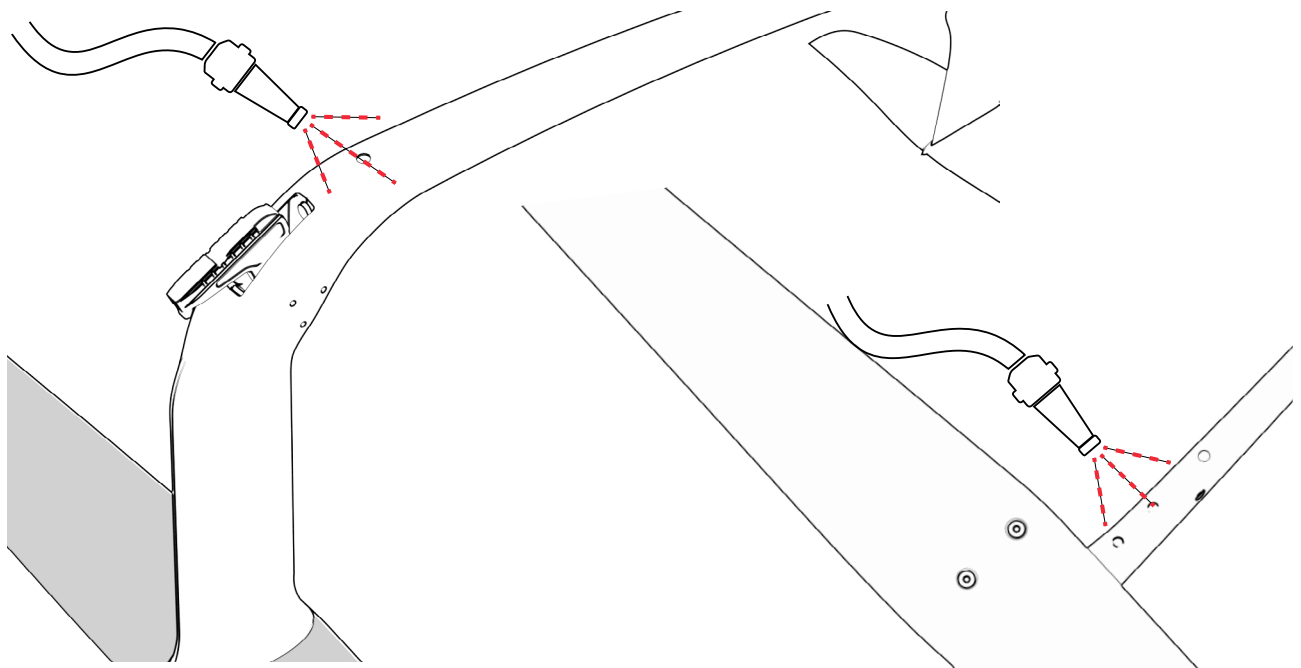

d. Tiller quick connect

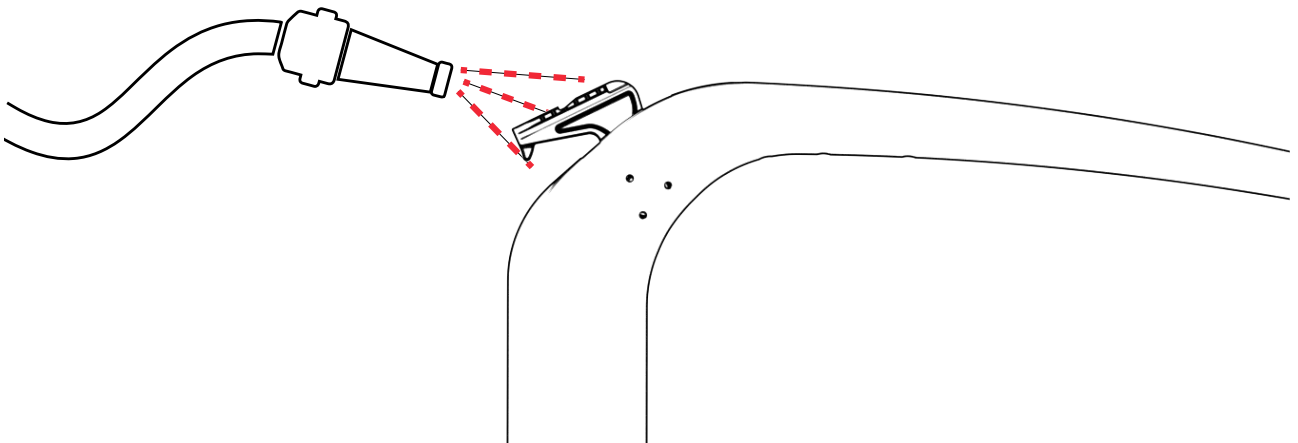

e. Bayonet upright & foil shoe

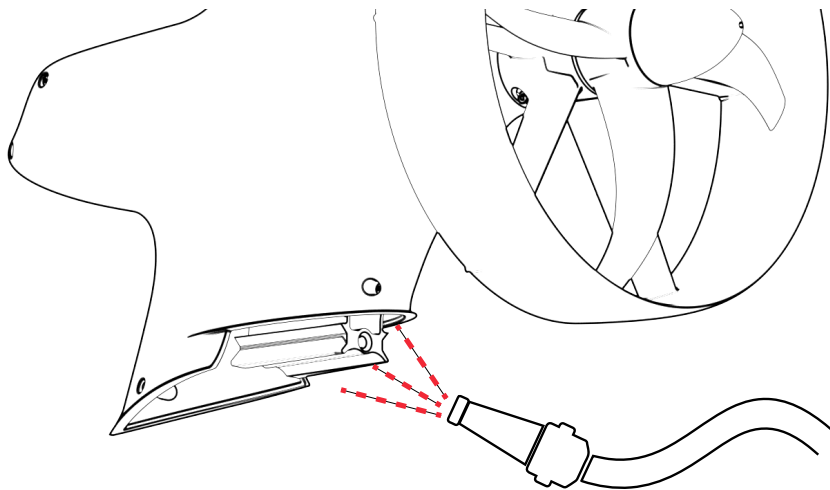

f. Chassis-drivechain connection

Rinsing the knob should be done when the drivetrain and chassis are disconnected to avoid water in the drivetrain connector. Furthermore, this should be left disassembled when stored for long periods of time.

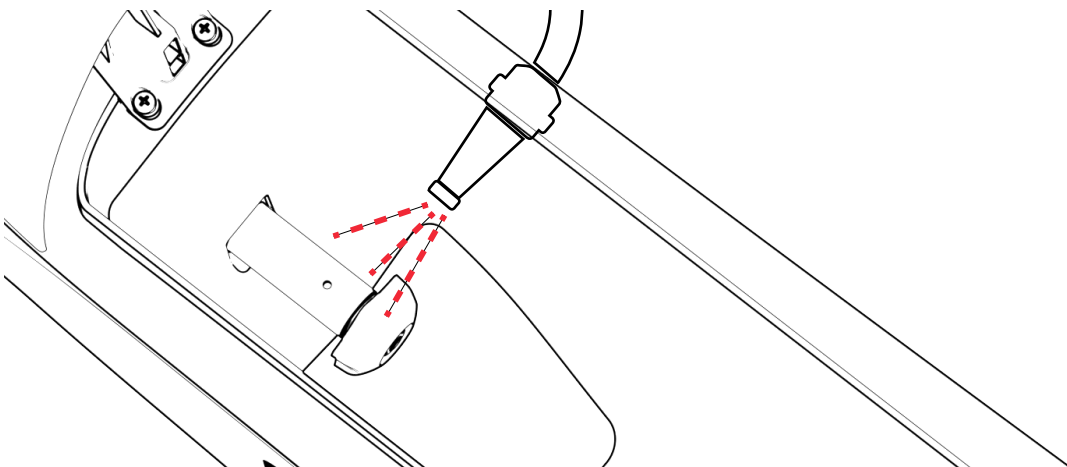

7.2 APPLY CONTACT LUBRICANT AFTER USE IN SALT WATER

Apply the provided contact lubricant to all the connectors pins as shown below:

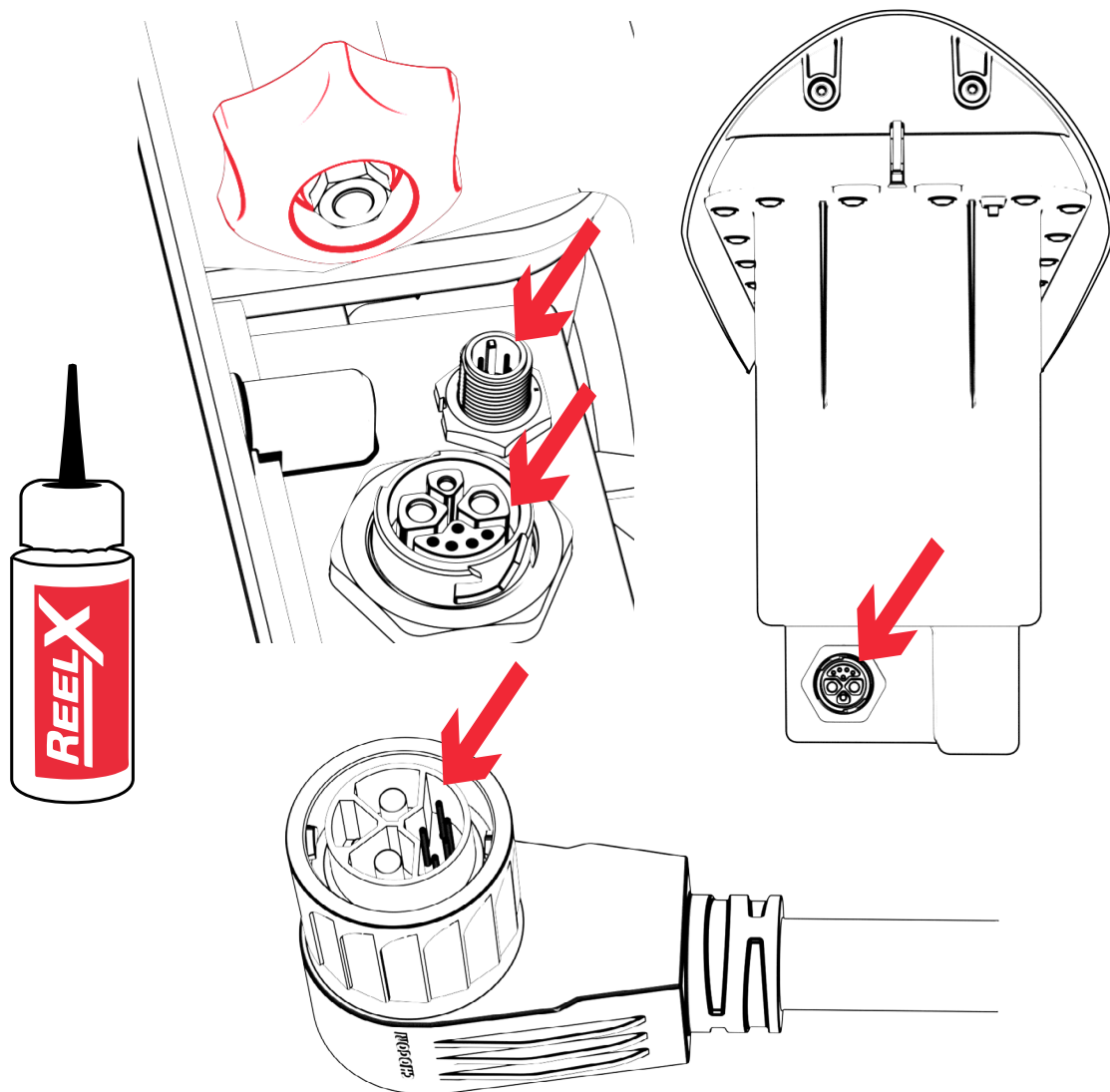

! NOTICE

- **Failure to maintain electrical connectors may cause electrical system failure**
- Disconnect the battery cable from both ends when finished with ride
- If in fresh water, simply ensure the connectors and pins are dry before storing the bike
- If any sign of corrosion is present on any of the pins, reapply electrical contact lubricant to the connectors once they are clean and dry

7.3 CHECK & MAINTAIN

a. Seat post & saddle

Check the tension of the fasteners that hold the seat post and saddle in place to ensure that they do not come loose during operation.

b. Stem

Check the tension of the fasteners that hold the stem in place to ensure that the handlebars do not come loose during operation.

c. Tension of front foil screws

Check the tension of the front foil screws. Tighten firmly by hand using the Allen key provided. Please refer to Section 4.3, page 19, for the initial assembly instructions of the front foil to the tiller.

7.4 INSPECT

a. Hydropack battery cable plug

Inspect that the plug of the battery cable has no damage, nor that there is no corrosion build up inside the plug. If there is any damage or corrosion to the battery cable plug, stop use immediately and contact your local reseller or servicing agent.

b. Ride Controller cable plug

Inspect that the plug of the ride controller cable has no damage of any form, nor that there is no corrosion build up inside the plug. If there is any damage or corrosion to the ride controller cable plug, you may experience errors when riding and contact your local reseller or servicing agent.

7.5 HYDROPACK BATTERY MAINTENANCE & STORAGE

The Hydropack battery life can be prolonged when being properly maintained and especially when being operated and stored at the right temperatures. With increasing age, however, the battery capacity will diminish, even when properly maintained. A significantly reduced operating period after charging indicates that the battery is worn out and must be replaced.

- a. Never store a completely discharged battery as it might result in permanent damage.
- b. The Hydropack battery should never be charged unattended.
- c. It is recommended to charge to 100% within 24hrs of riding and should not be stored at 100% charge.
- d. The Hydropack battery should not be charged to at least 30% before long-term storage. We recommend a storage charge at least once a year when the SL3 has not been used.
- e. It is not recommended to have the Hydropack battery connected permanently to the charger.
- f. Store the battery in the following locations:
 - In a room with a smoke alarm.
 - Away from combustible or easily flammable objects.
 - Away from heat sources
- g. The battery should be oriented upright when charging (the handle at the top) and during storage.
- h. Store the battery at temperatures between 10°C and 20°C (50°F and 68°F). Never store a battery at temperatures below -10°C (14°F) or above +60°C (140°F). To ensure that the battery lifetime is as long as possible, storage at approximately 20°C (room temperature) is recommended. As an example, do not leave the battery in a vehicle in summer and store it out of direct sunlight.
- i. Do not leave the Hydropack battery secured into the Hydrofoiler for long periods. It should be removed between foiling sessions as well as for long term storage.

7.6 CHASSIS AND DRIVETRAIN STORAGE

- a. The chassis and the drivetrain can remain assembled. However, loosen the chassis lock to reduce the risk of chassis-drivetrain locking surfaces potentially seizing during storage.
- b. Store in a clean, dry and cool environment, out of the sun.
- c. Additional rear foil shoes can be purchased for storage solutions (contact your local Manta5 reseller to order an additional rear foil shoe).

7.7 FOIL STORAGE

- a. Before storage, wash down the foils with fresh water and dry them.
- b. Stow the foils in a secure place to prevent damage.



8. PRODUCT SUPPORT

8.1 WARRANTY REGISTRATION

The Manta5 Hydrofoiler SL3 is covered by the Manta5 Global Warranty (Section 12). However, for the Manta5 Global Warranty to be valid, the Dealer needs to register the warranty of the SL3. It is the customer's responsibility to ensure that their dealer has correctly registered the warranty of their Hydrofoiler SL3 upon purchase. If in doubt, register here:



<https://manta5.com/partners/product-registration/>

8.2 DIAGNOSIS & REPAIRS

For the most common and recent issue diagnosis articles refer to the below:



<https://manta5.com/support/hydrofoiler-sl3-technical-support/>

For all repairs, please contact your dealer/reseller. Otherwise, contact the nearest qualified Manta5 servicing agent or partner that would be able to facilitate this. Any repairs attempted by non-authorized persons may risk voiding the Manta5 Global Warranty.

8.3 SERVICING REQUIREMENTS

The SL3 must be serviced regularly to ensure a long-lifetime and correct performance. Refer to the required service activity below that must be undertaken by a qualified Manta5 servicing agent. The Manta5 Global Warranty may be voided if the required servicing schedule is not followed.

REQUIRED SERVICE ACTIVITY	REGULAR 200 HR SERVICE OR 12 MONTHLY (200,400,...)
Service by authorised servicing agent	✓

8.4 HYDROFOILER SL3 SERVICE LOG

Associated documentation must be completed at each service or maintenance

CUSTOMER FIRST NAME	
CUSTOMER LAST NAME	
CUSTOMER PHONE	
CUSTOMER EMAIL	

DATE	WORK PERFORMED	PERFORMED BY	NOTES



9. MANTA5 GLOBAL WARRANTY

This Manta5 Limited Warranty (“Warranty”) is a voluntary manufacturer’s warranty by Manta5 LP, a New Zealand limited partnership (limited partnership number 2592602), acting via its general partner Bright Spark Innovations GP Limited, a New Zealand company (company number 4749042) (“Manta5”). This Warranty applies to the products listed below. Your legal rights as a purchaser may vary by country or jurisdiction. This Warranty does not affect these rights.

Before using the product, please read all Manta5’s “Product Materials” including, without limitation, user manuals, safety guidelines, specifications, training videos, social media posts, and service communications from Manta5 or its authorised representatives. Manta5 product warranty registration must be completed upon purchase through the required monthly warranty reporting.

Manta5 warrants for the relevant coverage periods that the Hydrofoiler will be free from defects in material and workmanship under normal use in accordance with Manta5’s Product Materials.

9.1 WHAT IS COVERED?

Warranty periods are from date of delivery and differ between products as detailed below. The following products are covered under warranty:

- **2-Year Warranty on Manta5 Hydrofoiler:**
 - Chassis

- Foils (front and rear)
- Motors
- Gearboxes
- Manta5 Hydrofoiler batteries (including battery): 1-year warranty or up to 250 charge cycles, whichever occurs first.

Proof of original retail purchase must be presented when making a claim under this warranty. Note that where the product is no longer owned by the original owner, the remaining warranty period (if any) is transferable to a second owner provided proof of original retail purchase is presented when making a claim.

9.2 WHAT IS NOT COVERED?

This Warranty is void under the following circumstances:

- Improper use of the Hydrofoiler, including excessive, or other abnormal use.
- Crash, physical impact, collisions or fire resulting from non-manufacturing processes, or use in unsafe locations or unsafe conditions.
- By damage or defects caused by transport, loading, unloading, dropping, out of water handling, or inappropriate storage including, without limitation, damage or defects caused by exposure to temperatures stated in the Product materials.
- Modification of the product without Manta5 approval.
- Improper maintenance or servicing (including any failure to comply with the Product Materials when maintaining or servicing the product), improper alteration, improper assembly and/or use of parts, accessories or software that are not compatible with the product.
- Wear and tear. Even when maintained correctly, some parts will eventually wear out and require replacement (such as seals, oil, bearings etc.). Similarly, the paint and bike graphics may be scratched as a result of normal use. Parts that are damaged due to wear and tear are not covered under this warranty.
- Commercial use of any kind.
- If the serial number has been removed or defaced.
- Colour matching of replacement parts is not included in this Warranty.
- This warranty does not cover any software programs, whether provided with the Hydrofoiler or installed subsequently, or any loss of the Customer's data.

9.3 HOW TO MAKE A CLAIM

All customers must contact their nearest authorized Manta5 dealer to make a warranty claim. Resellers

must submit all warranty claims directly to their Distributor or Wholesale Regional Distributor they purchased product from.

Distributor and Wholesale Regional Distributor Partners must submit warranty claims received by their reseller networks directly to Manta5 for approval via ticket only. The ticket process for warranty claim can be received by contacting Manta5 customer support (support@manta5.com).

In the event that a valid warranty claim is made, Manta5 may either opt to request that the dealer/distributor repair the product, or replace it with a similar product as then available.

This warranty is governed by the laws of New Zealand. In the event of any translation, the English version of the warranty will prevail. In the event of any dispute, the parties irrevocably submit to the exclusive jurisdiction of the courts of New Zealand.

manta5

HYDROFOIL BIKES