



OUTFITTER BALE BLIND ASSEMBLY INSTRUCTIONS

READ THESE INSTRUCTIONS IN ENTIRETY PRIOR TO ASSEMBLING THIS PRODUCT

WARNING! The safe use and operation of this product is the sole responsibility of the user. It is also the sole responsibility of the owner to provide any person(s) who borrow or purchase this product with this instruction manual. Additionally, failure to follow these instructions may subject you to personal liability penalties as determined by the U.S. Judicial system.

WARNING! Do not remove, modify and/or omit any portion or otherwise mechanically modify this product(s) or its assemblies in any manner. Modification, misuse and/or part substitution shall immediately void your factory warranty. If you suspect that a part(s) is missing and/or defective, immediately discontinue all use of the product and contact Redneck Manufacturing at 877-523-9986 for replacement of missing or defective parts.

WARNING! Before digging always contact your local One-Call system to prevent personal injury, Interruption of services, environmental accidents or job delays. Electric lines can shock or electrocute. Gas lines can rupture causing explosion or fire. Laser light in fiber optic cable can cause blindness. One-Call will notify participating utility companies of your proposed project. If you do not know the number for the local One-Call, call the National One-Call at 1-888-258-0808 for this information.

NOTE: Assembling this product does not require more than one individual, but some steps in the assembly process may be easier achieved with assistance. For this reason, we recommend assembling this product with the aid of an additional person, so assistance can be provided when needed.

NOTE: Some parts of this product are manufactured to be universal in use, so there may be some parts containing holes that will not be used in the assembly of this particular model. To minimize confusion in the assembly process, please read these instructions in entirety before beginning.

NOTE: When transporting your assembled Redneck Bale Blind, we recommend first removing the hay blankets and silent slide window coverings from the completely assembled frame. This will help prevent unnecessary wear and tear to your bale blind blanket.

NOTE: REMOVE COVER DURING OFFSEASON. Redneck Blinds strongly recommends removing your Soft Side Cover when hunting season is over. This will help prolong the life of the cover by preventing sun fading, rodent damage, and tattering from strong winds. READ THESE INSTRUCTIONS IN THEIR ENTIRETY PRIOR TO ASSEMBLING THIS PRODUCT.

Should you have any questions about the assembly, installation or use of this product, or any other Redneck Outdoor product, please call one of our customer service representatives toll free at 877-523-9986.

STEP 1: Remove all parts from the packaging and familiarize yourself with all the parts and tools required. Find the bill of materials on pages 18-20 and verify that all parts and hardware are present.

STEP 2: Locate the (2) LOWER WINDOW BRACES "C" and the (2) LOWER WINDOW BRACE EXTENSIONS "CC" and (8) CROSS MEMBER BRACES "G". Slide the LOWER WINDOW BRACE EXTENSIONS "CC" into the corresponding opening in the LOWER WINDOW BRACES "C". Align the CROSS MEMBER BRACES "G" with the corresponding holes, as illustrated in Figure 10.1, and fasten with the hardware (2) 1.5" Bolts (2) 1.25" Bolts and (4) Nuts in the hole locations. This will create the (2) parts COMPLETED LOWER WINDOW BRACE, as it will be referred to in the remainder of the assembly manual.

NOTE: Make sure the (4) Set Screws already installed in the LOWER WINDOW BRACES "C" and the LOWER WINDOW BRACE EXTENSIONS "CC" are facing the same direction, and the CROSS MEMBER BRACES "G" are installed on the opposite side of the horizontal Set Screws, as illustrated in Figure 10.1. Where the CROSS MEMBER BRACES "G" share a hardware location with LOWER WINDOW BRACE EXTENSIONS "CC", use the 1.5" Bolt.

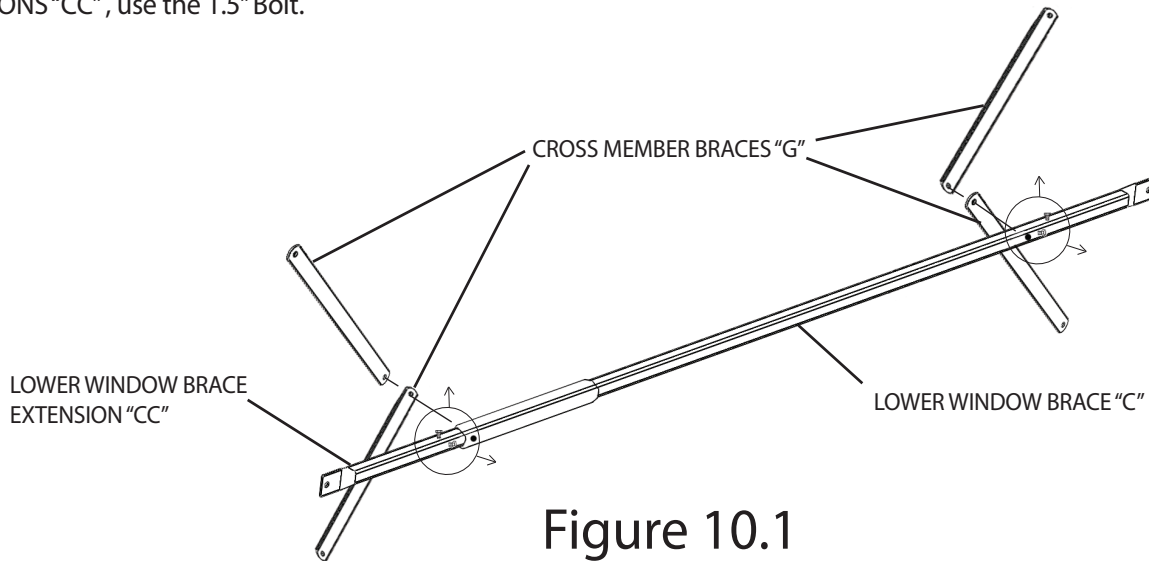

Figure 10.1

These (2) parts will be referred to as **COMPLETED LOWER WINDOW BRACE** in remainder of assembly instructions.

STEP 3: Locate (2) SIDE BRACES "E", (2) SIDE BRACE EXTENSIONS "EE" and (4) CROSS MEMBER BRACES "G". Slide the SIDE BRACE EXTENSIONS "EE" into the corresponding opening in the SIDE BRACES "E". Align the CROSS MEMBER BRACES "G" with the corresponding holes, as illustrated in Figure 11.1, and fasten with the hardware (2) 1.5" Bolts (2) 1.25" Bolts and (4) Nuts in the hole locations. This will create the (2) parts COMPLETED SIDE BRACE WITH TWO CROSS MEMBERS, as it will be referred to in the remainder of the assembly manual.

NOTE: Make sure the (2) Set Screw already installed in the SIDE BRACES "E" and the SIDE BRACE EXTENSIONS "EE" are facing the same direction, as illustrated in Figure 11.1. Where the CROSS MEMBER BRACES "G" share a hardware location with SIDE BRACE EXTENSION "EE", use the 1.5" Bolt.

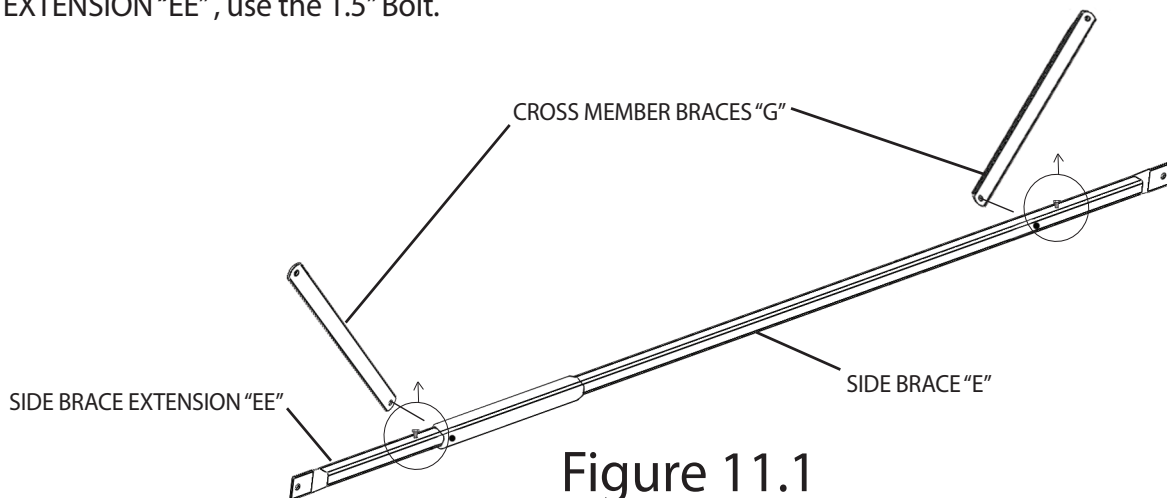

Figure 11.1

These (2) parts will be referred to as **COMPLETED SIDE BRACE WITH TWO CROSS MEMBERS** in remainder of assembly instructions.

STEP 4: Locate (1) SIDE BRACE "E" , (1) SIDE BRACE EXTENSION "EE" and (4) CROSS MEMBER BRACES "G". Slide the SIDE BRACE EXTENSIONS "EE" into the corresponding opening in the SIDE BRACE "E" . Align the CROSS MEMBER BRACES "G" with the corresponding holes , as illustrated in Figure 12.1, and fasten with the hardware (1) 1.5" Bolt (1) 1.25" Bolt and (2) Nuts in the hole locations. This will create the (1) part COMPLETED SIDE BRACE WITH FOUR CROSS MEMBERS , as it will be referred to in the remainder of the assembly manual.

NOTE: Make sure the (2) Set Screw already installed in the SIDE BRACE "E" and the SIDE BRACE EXTENSION "EE" are facing the same direction, as illustrated in Figure 12.1. Where the CROSS MEMBER BRACES "G" share a hardware location with SIDE BRACE EXTENSION "EE" , use the 1.5" Bolt.

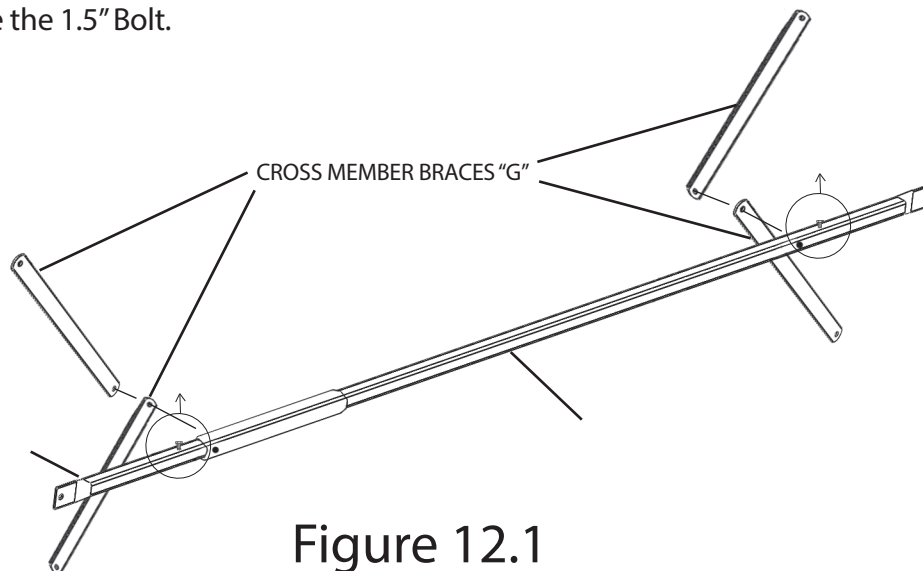

Figure 12.1

This (1) part will be referred to as **COMPLETED SIDE BRACE WITH FOUR CROSS MEMBERS** in remainder of assembly instructions.

STEP 5: Locate the remaining (4) SIDE BRACES "E" and (4) SIDE BRACE EXTENSIONS "EE". Slide the SIDE BRACE EXTENSION "EE" into the corresponding opening in the SIDE BRACE "E" , as illustrated in Figure 13.1, and fasten with the hardware (4) 1.5" Bolts (4) 1.25" Bolts and (8) Nuts in the hole locations. This will create the (4) parts COMPLETED SIDE BRACE , as it will be referred to in the remainder of the assembly manual.

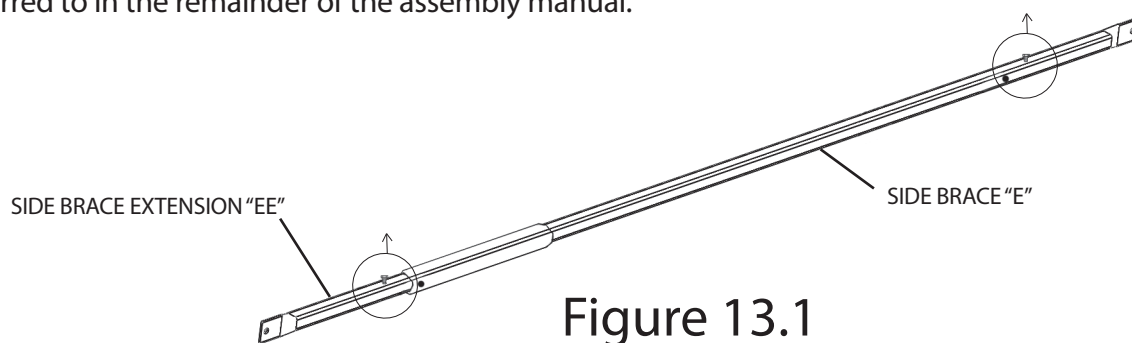

Figure 13.1

These (4) parts will be referred to as **COMPLETED SIDE BRACE** in remainder of assembly instructions.

STEP 6: Locate the (2) END FRAME BOTTOM HOOPS "M" and (2) COMPLETED SIDE BRACES. Using the hardware connection in (4) places, align and fasten the hole ends of the (2) COMPLETED SIDE BRACES with the corresponding holes in the (2) END FRAME BOTTOM HOOPS "M" , as illustrated in Figure 14.1, fastening with the hardware (4) 1.5" Bolts and (4) Nuts.

NOTE: Make sure the (6) Set Screws already installed in the (2) END FRAME BOTTOM HOOPS "M" are facing towards the interior of the blind, as illustrated in Figure 14.1 & 14.2. The (4) Set Screws in the (2) COMPLETED SIDE BRACES need to be facing up, as illustrated in Figure 14.1.

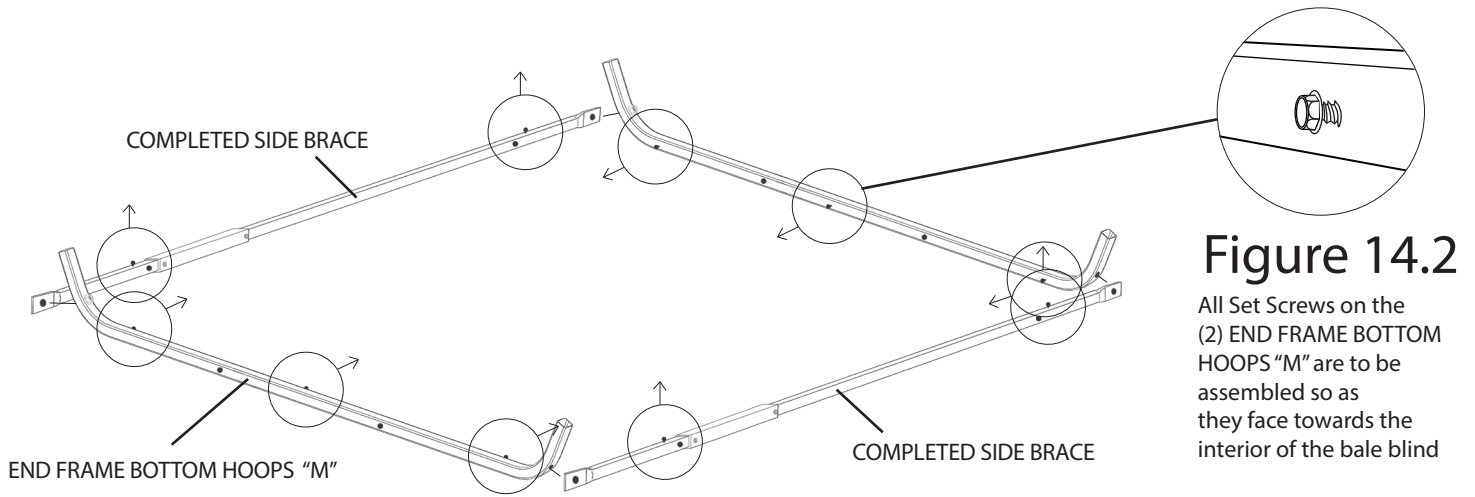

Figure 14.2

All Set Screws on the (2) END FRAME BOTTOM HOOPS "M" are to be assembled so as they face towards the interior of the bale blind

Figure 14.1

STEP 7: Locate the (3) parts that will be assembled to create the first section of the bale blind frame. These parts are (2) END FRAME LOWER SIDE HOOPS "K" and (1) COMPLETED LOWER WINDOW BRACE. Using the hardware connection in (2) places, align and fasten the hole ends in the COMPLETED LOWER WINDOW BRACE with the upper most holes in the (2) END FRAME LOWER SIDE HOOPS "K", and fasten with (2) Bolts and (2) Nuts. Next align the hole ends of the bottom (2) CROSS MEMBER BRACES "G" with the corresponding holes in the (2) END FRAME LOWER SIDE HOOPS "K", and fasten with (2) Bolts and (2) Nuts, as illustrated in Figure 15.1.

NOTE: On the COMPLETED LOWER WINDOW BRACE, make sure (2) Set Screws already installed are facing towards what would be the interior of the blind, while the other (2) Set Screws already installed are facing upwards, as illustrated in Figure 15.1. The Set Screw already installed on the (2) END FRAME LOWER SIDE HOOPS "K" need to be facing towards the interior of the frame, as illustrated in Figure 15.1.

NOTE: The bottom (2) CROSS MEMBER BRACES "G" will have their opposing end fastened to the (2) END FRAME LOWER SIDE HOOPS "K", while the top (2) CROSS MEMBER BRACES "G" will have their opposing ends not fastened to any part, as illustrated in Figure 15.1.

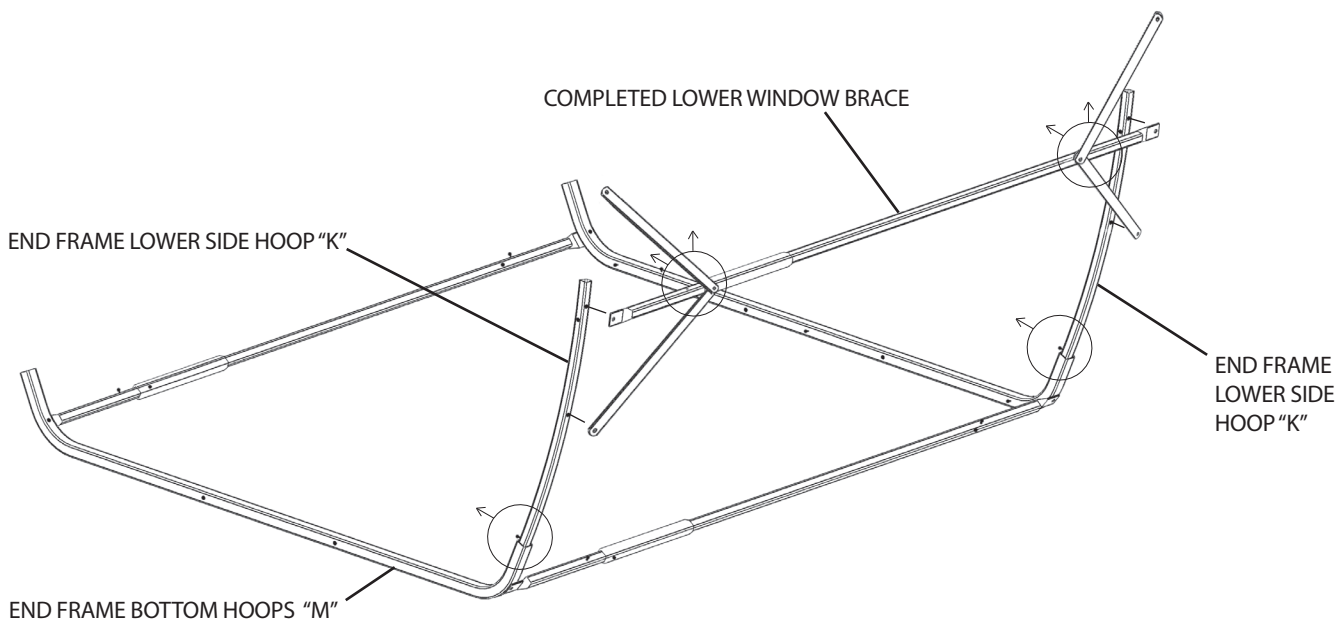

Figure 15.1

STEP 8: Install Section 1 that was created in Step 7, into the base that was created in Step 6, resulting in the frame illustrated in Figure 16.1.

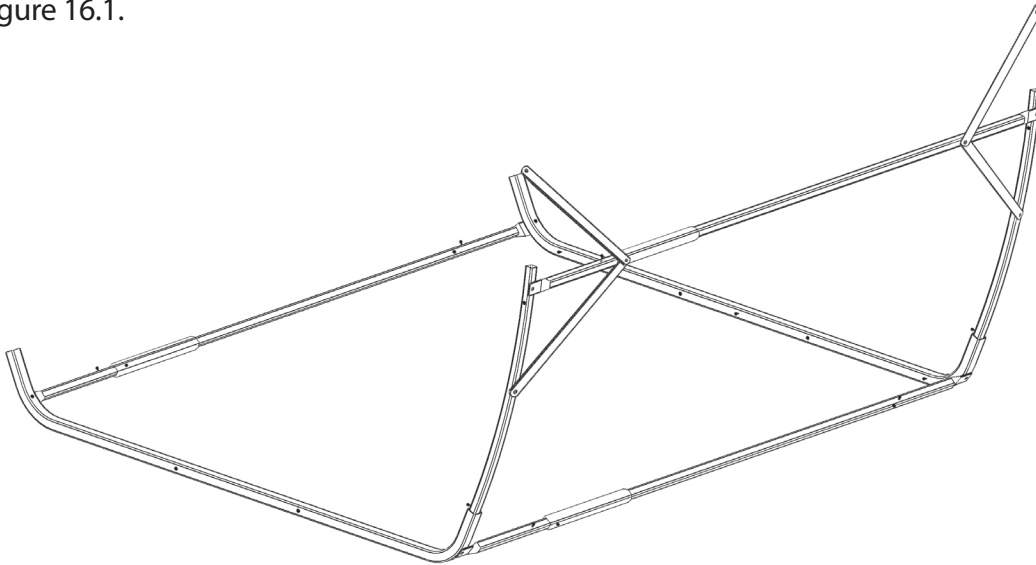

Figure 16.1

STEP 9: Locate the (3) parts that will be assembled to create the second section of the bale blind frame. These parts are (1) COMPLETED SIDE BRACE WITH TWO CROSS MEMBERS, (1) END FRAME UPPER SIDE HOOP WITH DOOR CATCHES "I" and (1) END FRAME UPPER SIDE HOOP "J". Using the hardware connection in (2) places, align and fasten the hole ends in the COMPLETED SIDE BRACE WITH TWO CROSS MEMBERS with the middle hole in the END FRAME UPPER SIDE HOOP WITH MAGNET "I" and the middle hole in the END FRAME UPPER SIDE HOOP "J", fastening with (2) Bolts and (2) Nuts. Next align the hole ends of the (2) CROSS MEMBER BRACES "G" with the upper most holes in the END FRAME UPPER SIDE HOOP WITH DOOR CATCHES "I" and the END FRAME UPPER SIDE HOOP "J", and fastening with (2) Bolts and (2) Nuts, as illustrated in Figure 17.1.

NOTE: On the END FRAME UPPER SIDE HOOP WITH DOOR CATCHES "I", make sure the door catches are facing towards what would be the exterior of the bale blind, as illustrated in Figure 17.1. On the COMPLETED SIDE BRACE WITH TWO CROSS MEMBERS, make sure the (2) Set Screws already installed are facing upwards, as illustrated in Figure 17.1.

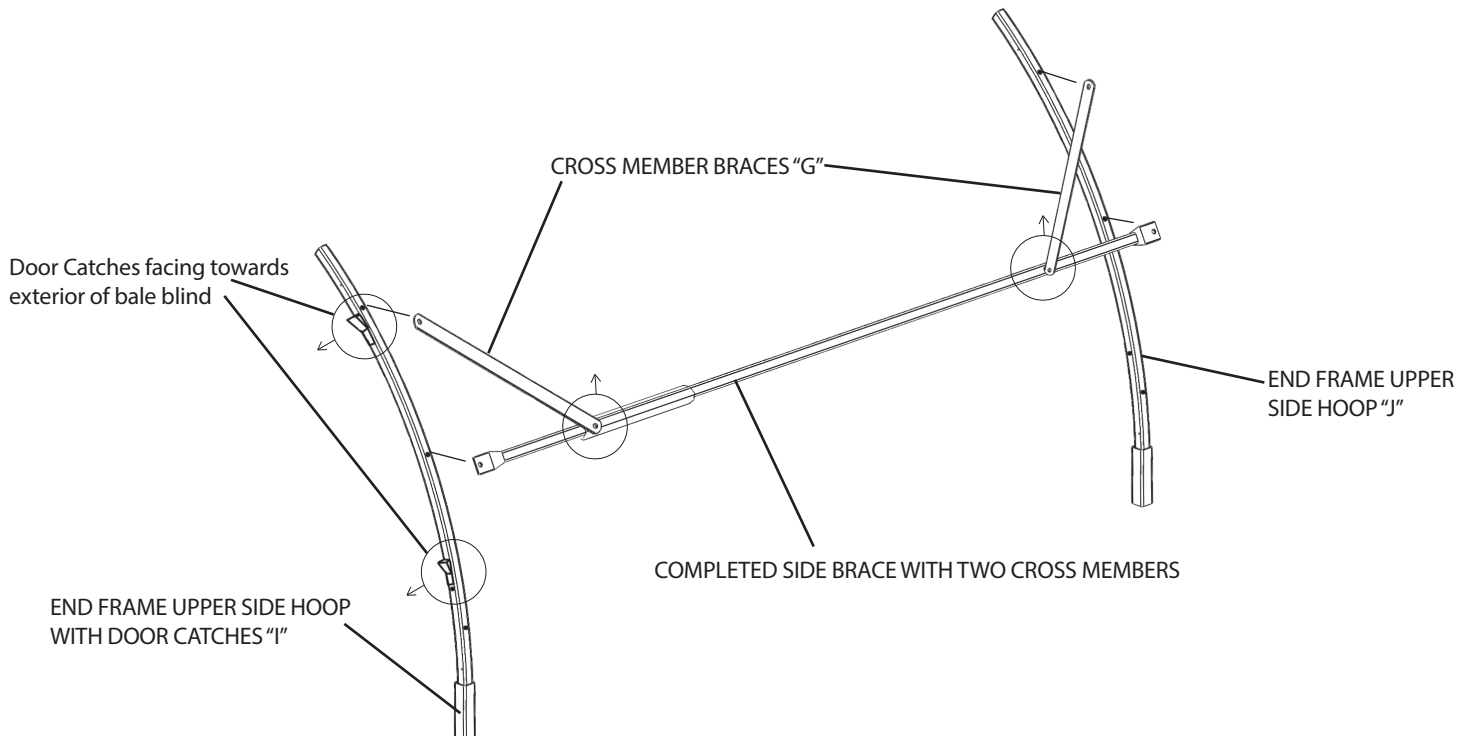

Figure 17.1

STEP 10: Install Section 2 that was created in Step 9, into Section 1 that was created in Step 7, resulting in the frame illustrated in Figure 18.1. Using the hardware connection in (2) places, align and fasten the (2) CROSS MEMBER BRACES "G" from Section 1 onto the corresponding holes on Section 2 with (2) Bolts and (2) Nuts, resulting in the frame illustrated in Figure 18.1.

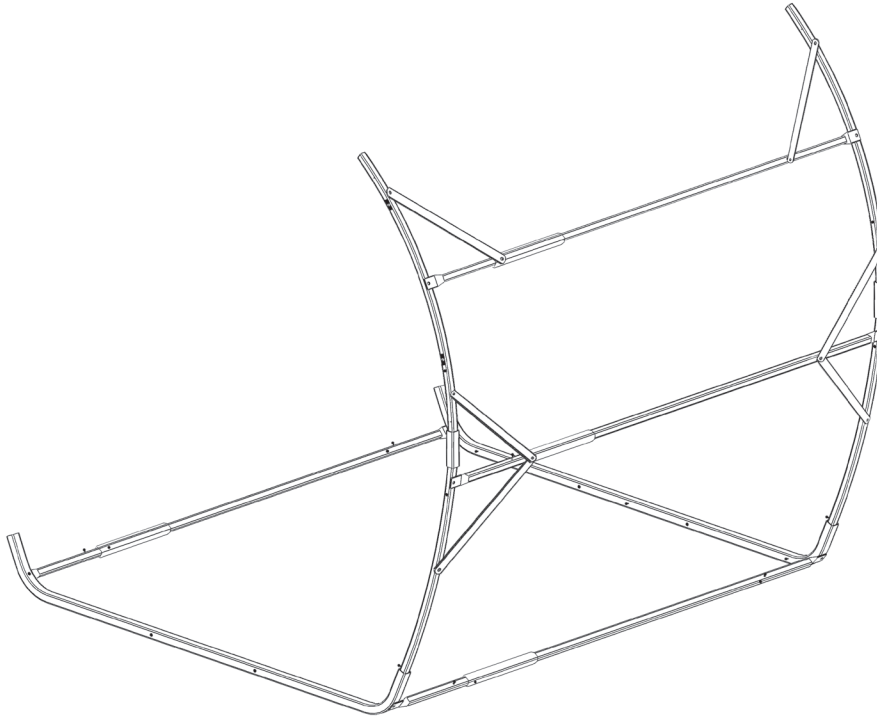

Figure 18.1

STEP 11: Locate the (5) parts that will be assembled to create the third section of the bale blind frame. These parts are the (2) END FRAME TOP HOOPS "H", (2) COMPLETED SIDE BRACES and (1) COMPLETED SIDE BRACE WITH FOUR CROSS MEMBERS. Using the hardware connection in (4) places, align and fasten the hole ends of the (2) COMPLETED SIDE BRACES with the corresponding holes in the (2) END FRAME TOP HOOPS "H", and fasten with (4) Bolts and (4) Nuts, as illustrated in Figure 19.1. Using the hardware connection in (6) places, align and fasten the hole ends of the (1) COMPLETED SIDE BRACE WITH FOUR CROSS MEMBERS with the corresponding holes in the (2) END FRAME TOP HOOPS "H", and fasten with (6) Bolts and (6) Nuts, as illustrated in Figure 19.1.

NOTE: The (2) COMPLETED SIDE BRACES to be installed on the outer most holes of the (2) END FRAME TOP HOOPS "H", will have their (4) Set Screws facing upwards, as illustrated in Figure 19.1.

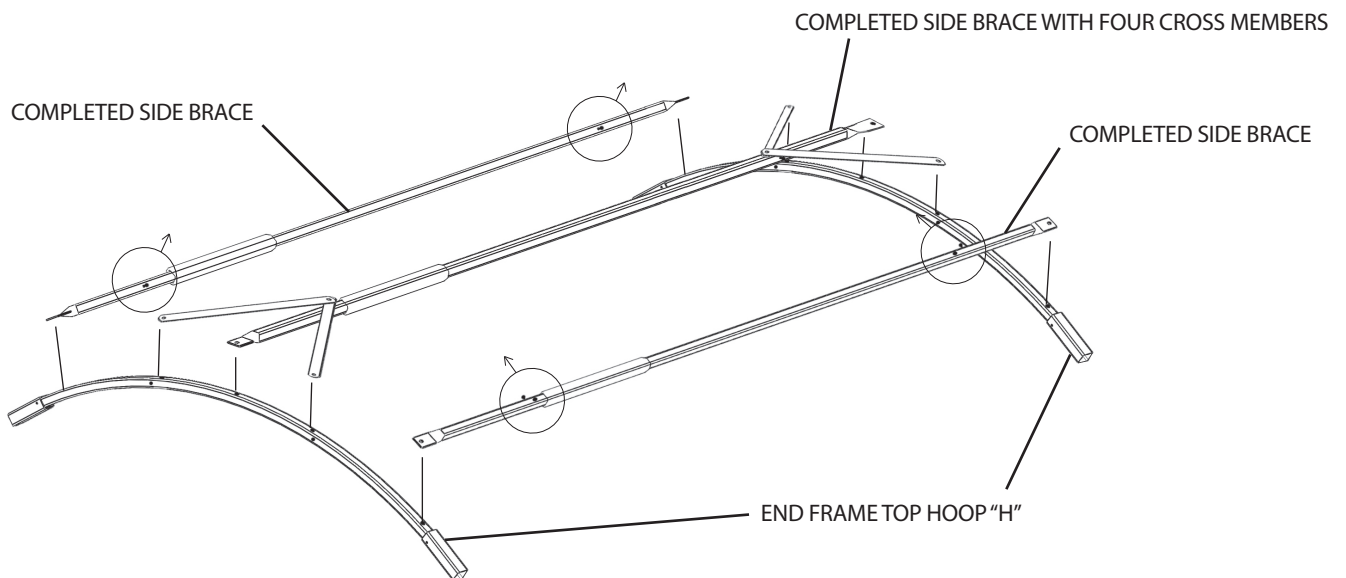

Figure 19.1

STEP 12: Install Section 3 that was created in Step 11, into Section 2 that was created in Step 9, resulting in the frame illustrated in Figure 20.1.

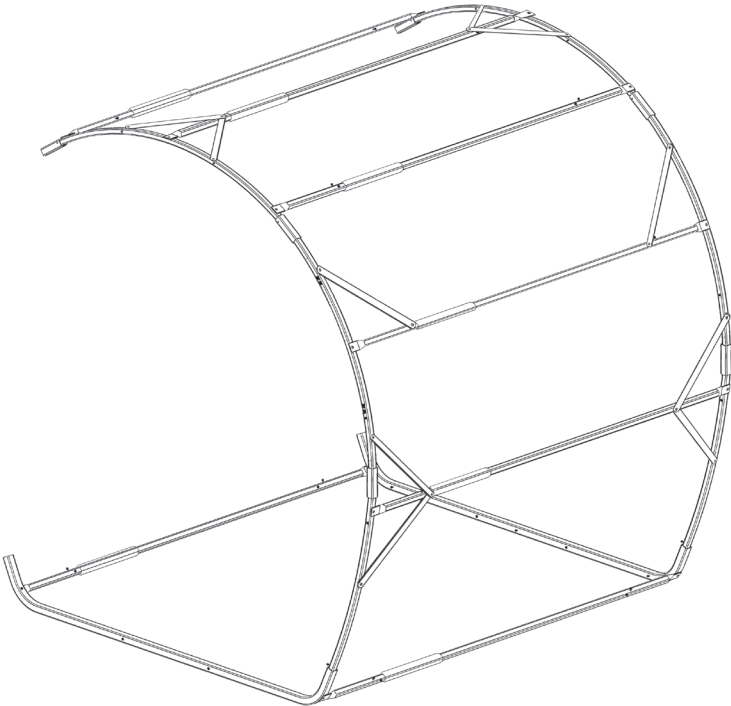

Figure 20.1

STEP 13: Locate the (3) parts that will be assembled to create the fourth section of the bale blind frame. These parts are (1) COMPLETED SIDE BRACE WITH TWO CROSS MEMBERS and (2) END FRAME UPPER SIDE HOOPS "J". Using the hardware connection in (2) places, align and fasten the hole ends in the COMPLETED SIDE BRACE WITH TWO CROSS MEMBERS with the middle hole in the the (2) END FRAME UPPER SIDE HOOP "J", fastening with (2) Bolts and (2) Nuts. Next align the hole ends of the (2) CROSS MEMBER BRACES "G" with the corresponding holes in the (2) END FRAME UPPER SIDE HOOP "J", and fastening with (2) Bolts and (2) Nuts, as illustrated in Figure 21.1.

NOTE: Step 13 assembly is similar to Step 9. On the COMPLETED SIDE BRACE WITH TWO CROSS MEMBERS, make sure the (2) Set Screws already installed are facing upwards, as illustrated in Figure 21.1.

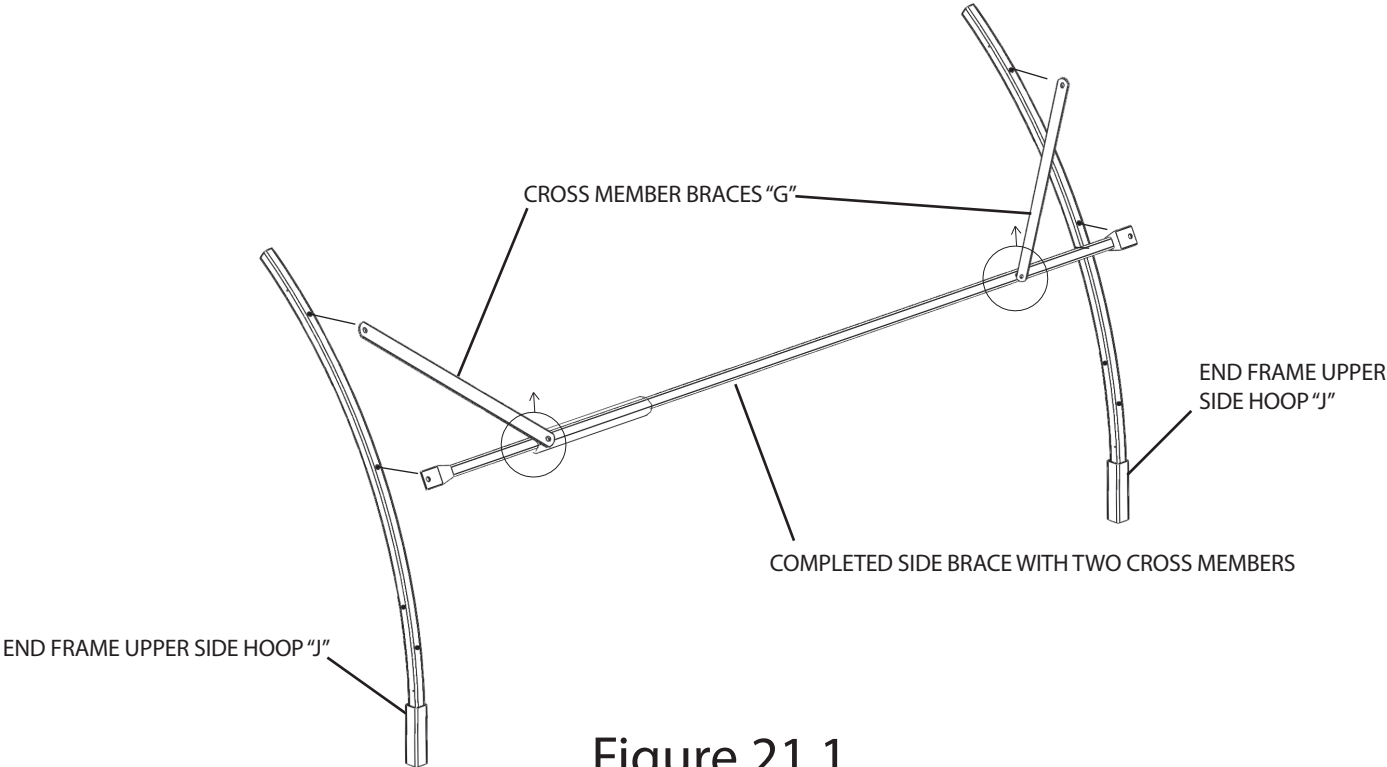

Figure 21.1

STEP 14: Locate the (3) parts that will be assembled to create the fifth section of the bale blind frame. These parts are (2) END FRAME LOWER SIDE HOOPS "K" and (1) COMPLETED LOWER WINDOW BRACE. Using the hardware connection in (2) places, align and fasten the hole ends in the COMPLETED LOWER WINDOW BRACE with the upper most holes in the (2) END FRAME LOWER SIDE HOOPS "K", and fasten with (2) Bolts and (2) Nuts. Next align the hole ends of the bottom (2) CROSS MEMBER BRACES "G" with the corresponding holes in the (2) END FRAME LOWER SIDE HOOPS "K", and fasten with (2) Bolts and (2) Nuts, as illustrated in Figure 22.1.

NOTE: Step 14 assembly is similar to Step 7. On the COMPLETED LOWER WINDOW BRACE, make sure (2) Set Screws already installed are facing towards what would be the interior of the blind, while the other (2) Set Screws already installed are facing upwards, as illustrated in Figure 22.1.

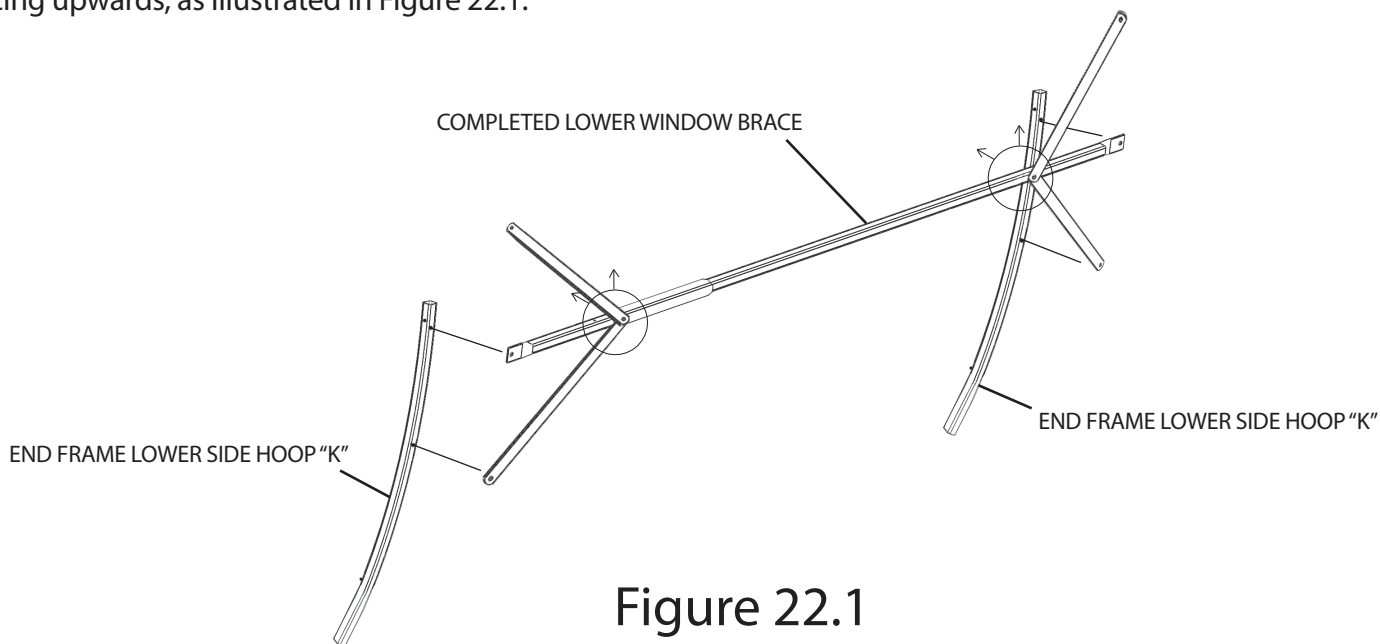

Figure 22.1

STEP 15: Install Section 4 that was created in Step 13, with Section 5 that was just created in Step 14, resulting in the frame section illustrated in Figure 23.1. Using the hardware connection in (2) places, align and fasten the (2) CROSS MEMBER BRACES "G" from Section 5 into the corresponding holes on Section 4 with (2) Bolts and (2) Nuts, resulting in the frame v in Figure 23.1

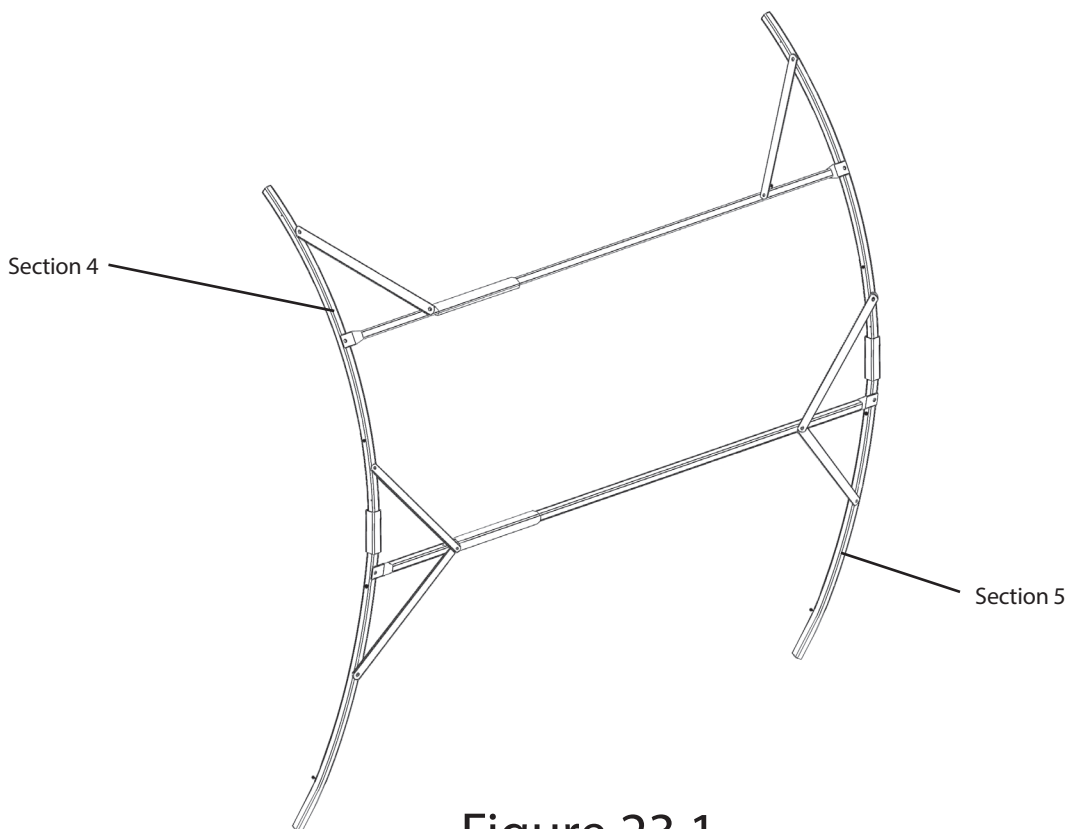

Figure 23.1

STEP 16: Install the top of Section 4 that was created in Step 13 into Section 3 that was created in Step 11 and install the bottom of Section 5 that was created in Step 14 into the frame base that was created in Step 6, resulting in the frame illustrated in Figure 24.1.

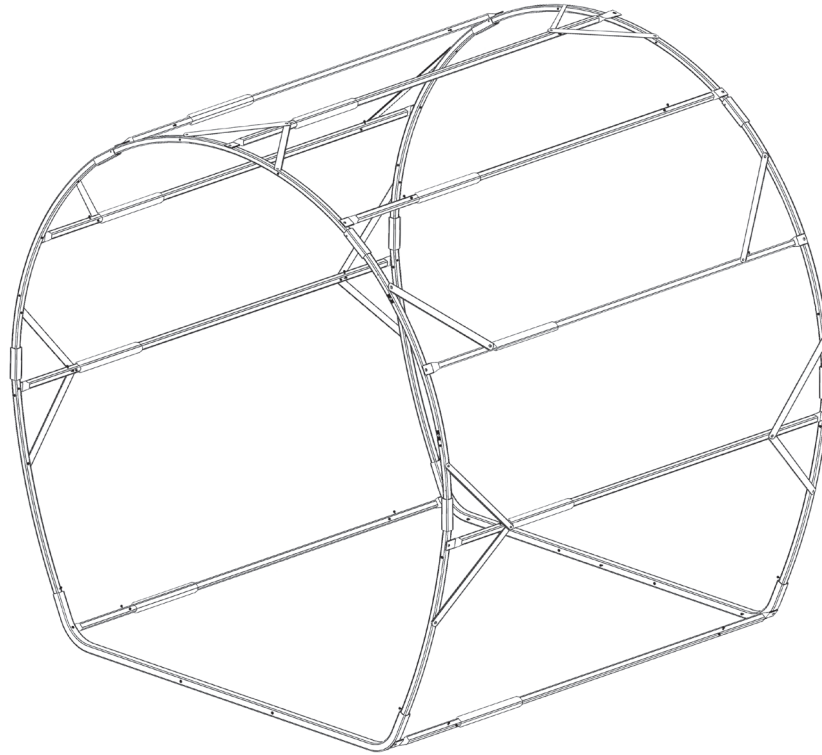

Figure 24.1

STEP 17: Locate the (2) END FRAME VERTICAL BRACES “B” and the (2) END FRAME VERTICAL BRACE EXTENSIONS “BB”. Slide the END FRAME VERTICAL BRACES “B” into the corresponding opening in the END FRAME VERTICAL BRACE EXTENSIONS “BB” as illustrated in Figure 25.1, and fasten with the hardware (1) 1.25” Bolt and (1) Nut. This will create part COMPLETED VERTICAL BRACE , as it will be referred to in the remainder of the assembly manual.

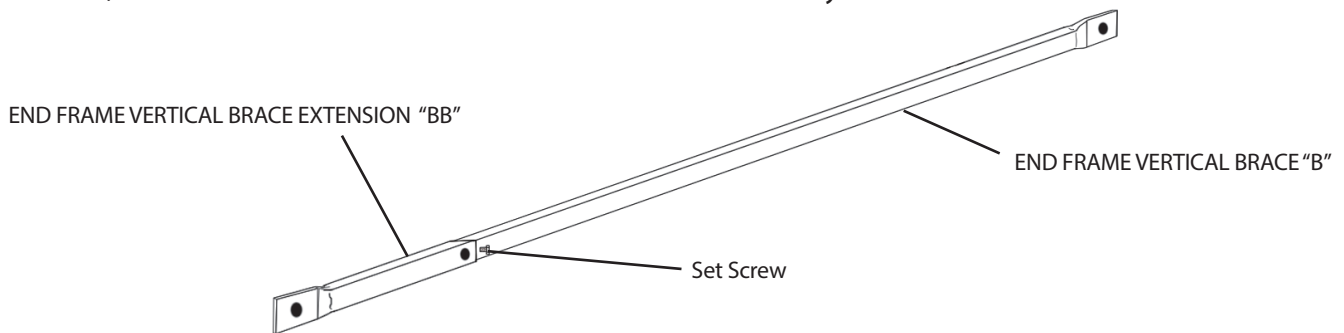

Figure 25.1

This part will be referred to as **COMPLETED VERTICAL BRACE** in remainder of assembly instructions.

STEP 18: Locate the (3) parts that will be assembled to create the support system for the door side end hoop, the side with the Magnet in it’s configuration. These parts are (1) COMPLETED VERTICAL BRACE and (2) END FRAME CROSS BRACE “F”. In this step you will also use the (1) Wing Nut and (1) 2” Bolt. All parts installed on this step are to be assembled on the outside of the existing frame, and the (2) END FRAME CROSS BRACES “F” will share a hardware connection location with the COMPLETED VERTICAL BRACE , where they join at the END FRAME BOTTOM HOOP “M” and END FRAME TOP HOOP “H”. Were the hardware connection is shared on the END FRAME BOTTOM HOOP “M”, this location will require (1) Wing Nut and (1) 2” Bolt. Make sure the COMPLETED VERTICAL BRACE is installed in such a way, that when viewed from the exterior of the blind, it is located on the right-hand side of the hoop, with it’s (1) Set Screw facing towards the interior of the blind.

Begin by starting at the bottom of the frame. Align and fasten the hole ends of the COMPLETED VERTICAL BRACE and (1) END FRAME CROSS BRACE "F" where they share a hardware connection at the END FRAME BOTTOM HOOP "M", and fasten with the (1) Wing Nut and (1) 2" Bolt, as illustrated in Figure 26.1 & 26.2. Next align and fasten the top part of the COMPLETED VERTICAL BRACE and the other (1) END FRAME CROSS BRACE "F" to the right-hand side corresponding hole in the END FRAME TOP HOOP "H", fastening with (1) 1.5" Bolt and (1) Nut. Then align and fasten the bottom END FRAME CROSS BRACE "F" to the corresponding hole in the END FRAME LOWER SIDE HOOP "K", fastening with (1) Bolt and (1) Nut, as illustrated in Figure 26.1. Finally align and fasten the top (1) END FRAME CROSS BRACE "F" to the corresponding hole in the END FRAME UPPER SIDE HOOP "J", fastening with (1) Bolt and (1) Nut.

NOTE: Assembly in this step is easier achieved by starting at the bottom of the frame and working your way up.

NOTE: All parts installed on this step are to be assembled on the outside of the existing frame, and the END FRAME CROSS BRACE "F" will share a hardware connection location with the COMPLETED VERTICAL BRACE, where they join at the END FRAME BOTTOM HOOP "M", connecting at this location with the (1) Wing Nut and (1) 2" Bolt, as illustrated in Figure 26.1 & 26.2.

NOTE: Make sure the COMPLETED VERTICAL BRACE is installed in such a way, that when viewed from the exterior of the blind, it is located on the right-hand side of the hoop, with it's (1) Set Screw facing towards the interior of the blind.

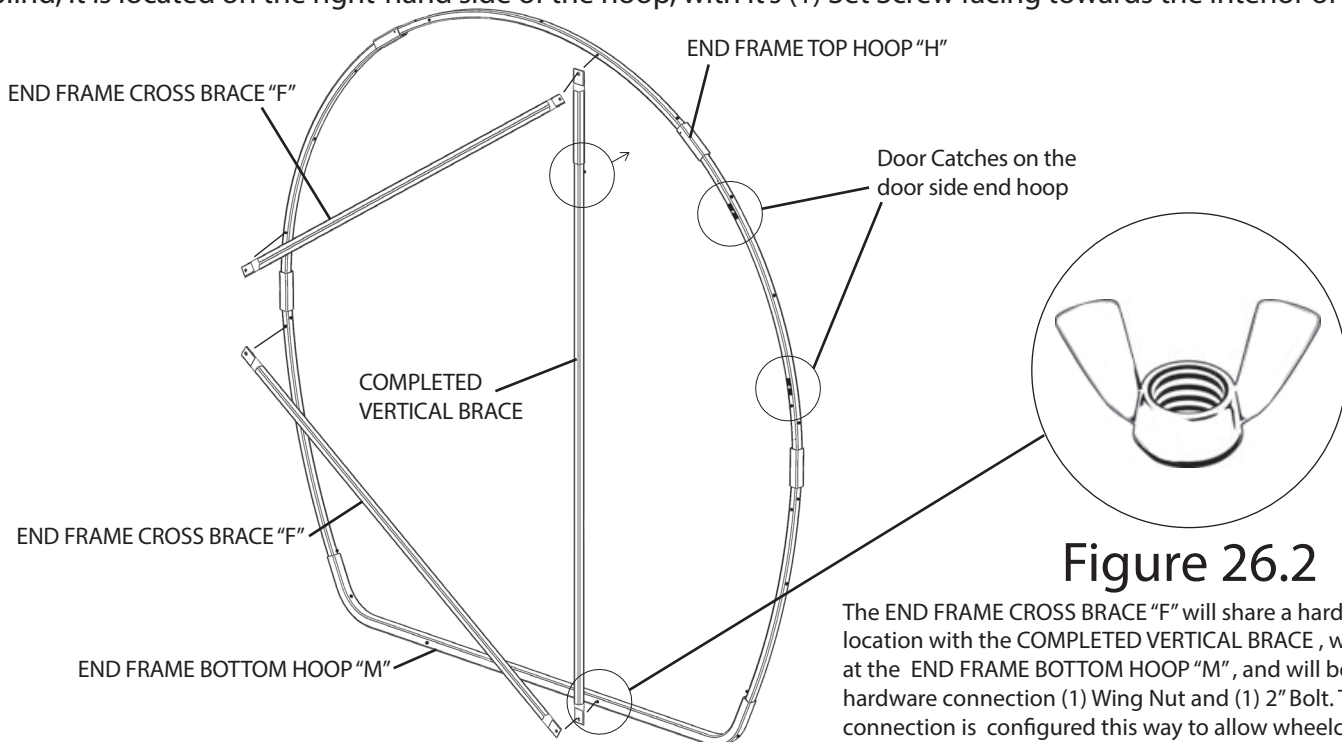

Figure 26.1

The END FRAME CROSS BRACE "F" will share a hardware connection location with the COMPLETED VERTICAL BRACE, where they join at the END FRAME BOTTOM HOOP "M", and will be fastened with the hardware connection (1) Wing Nut and (1) 2" Bolt. The hardware connection is configured this way to allow wheelchair access on the door side end hoop.

STEP 19: Repeat Step 18 to create the support system for the opposing end hoop, with the exception that there will not be a Wing Nut used in this step, only (4) Nuts, resulting in the frame illustrated in Figure 27.1.

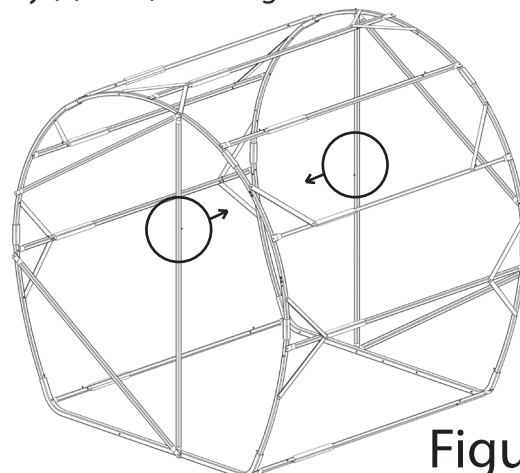

Figure 27.1

STEP 20: Locate the (4) TOP CROSS BRACES "L". Begin by unfolding the (4) TOP CROSS BRACES "L" and locking them in their extended position, as illustrated in Figure 28.1.

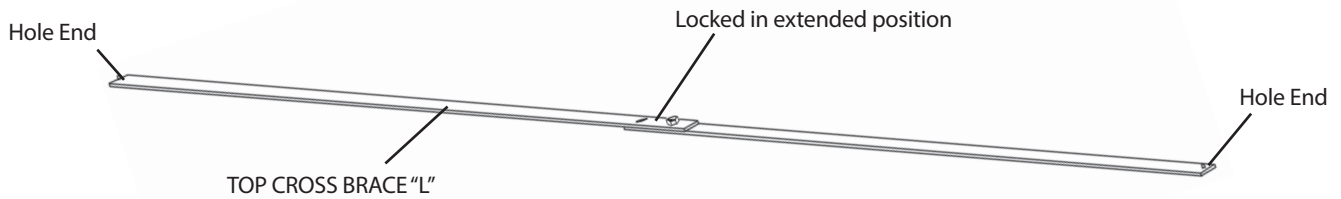

Figure 28.1

STEP 21: The (4) TOP CROSS BRACES "L" will be installed along the top part of your bale blind frame, on the outside of the (3) COMPLETED SIDE BRACES in Section 3, with their hole end resting under the (2) COMPLETED SIDE BRACES located in Section 2 and Section 4, resulting in the frame illustrated in Figure 29.1. Then fasten hole ends with Zip-Ties.

NOTE: If performing this step without assistance, assembly is easier achieved by standing inside the interior of the blind, and bending the (4) TOP CROSS BRACES "L" down over the (3) COMPLETED SIDE BRACES in Section 3, then sliding each hole end under the (2) COMPLETED SIDE BRACES located in Section 2 and Section 4.

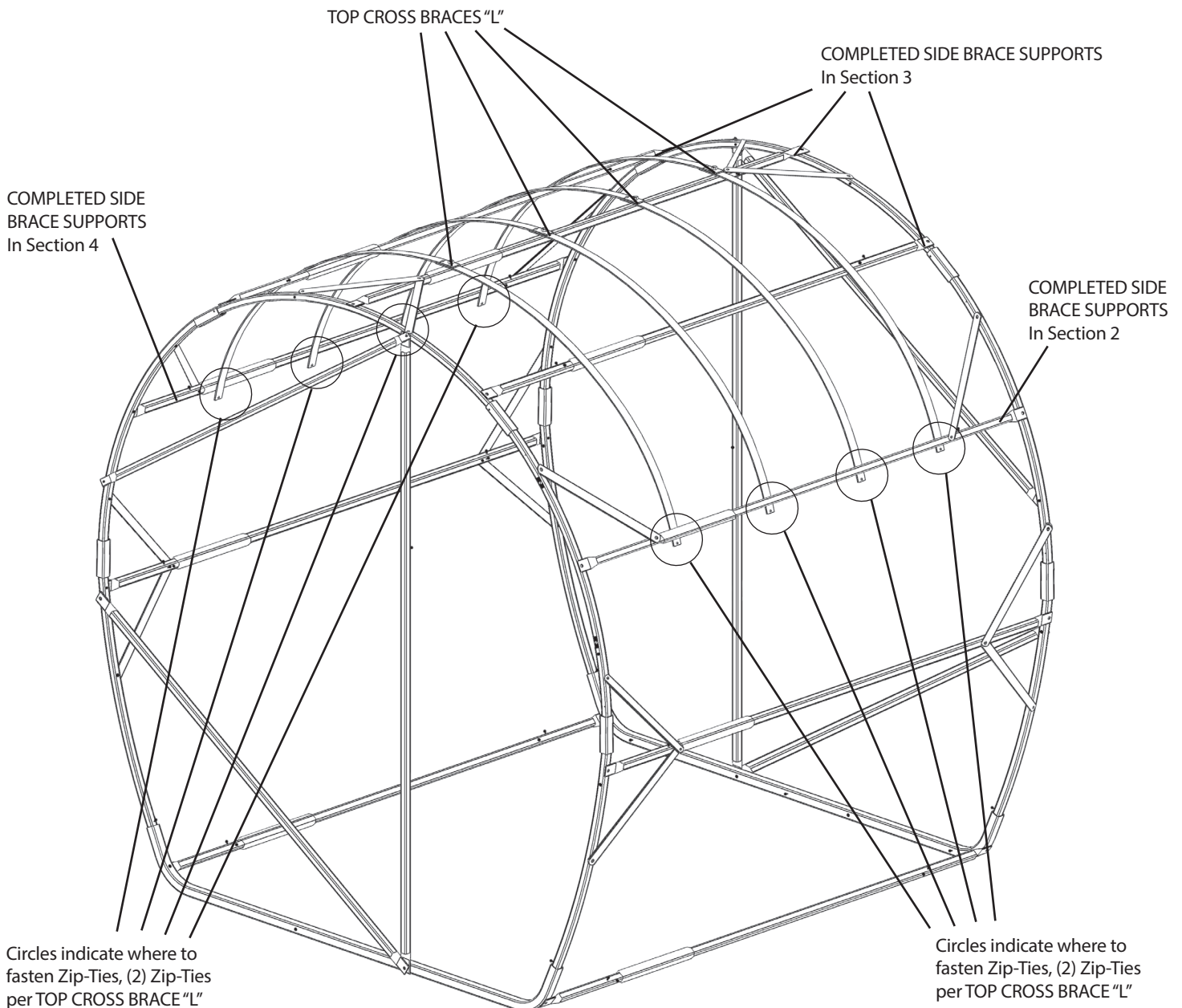

Figure 29.1

STEP 22: Locate the (4) TOP BLANKET SUPPORTS "Z". Begin by unfolding the (4) TOP BLANKET SUPPORTS "Z" and locking them in their extended position, as illustrated in Figure 30.1. If needed, tighten the Bolt and Nut to secure part in extended position.

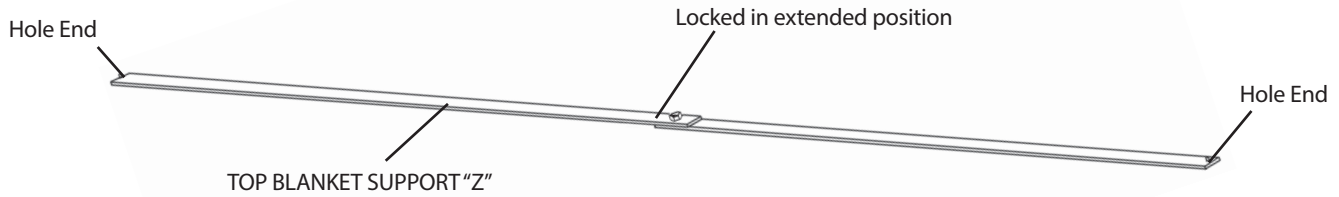

Figure 30.1

STEP 23: Using a total of (24) Zip-Ties, (6) Zip-Ties per TOP BLANKET SUPPORT "Z", align and fasten the (4) TOP BLANKET SUPPORTS "Z" along the top of the bale blind frame. Begin at the hole ends of the TOP BLANKET SUPPORT "Z", attaching each end to the End Hoop frame, then attach the middle portion of the TOP BLANKET SUPPORT "Z" where it lays over each TOP CROSS BRACE "L", as illustrated in Figure 31.1.

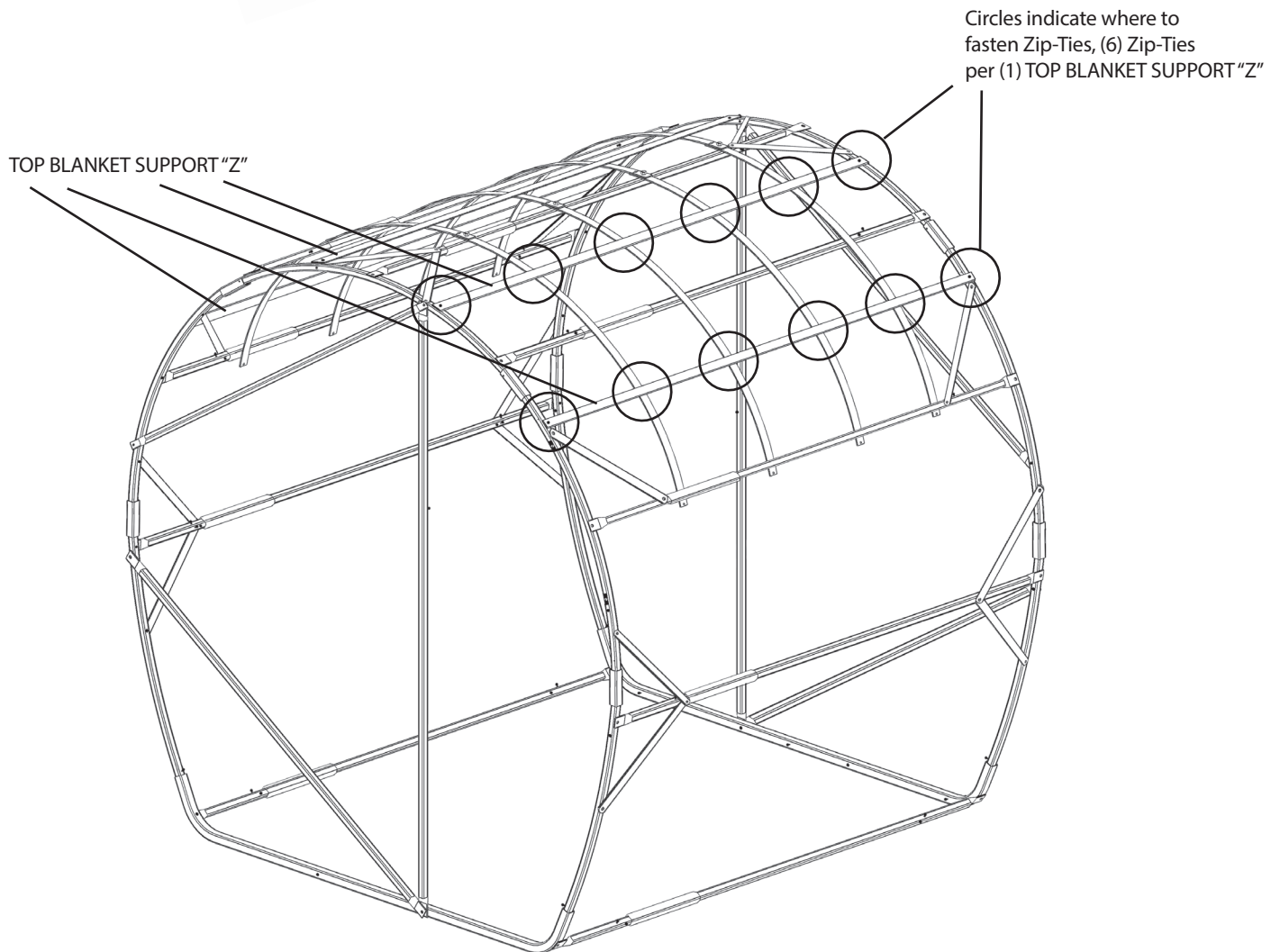

Figure 31.1

STEP 24: Locate the (1) DOOR SIDE END BLANKET WITH MAGNET "N" that will be installed on the door side end hoop, the side of the frame with the Magnet in it's configuration. Installation will begin at the top, and work downward following around the perimeter of the end hoop, initially using the loosest possible setting on the bungee straps. Once the end blanket is in place, the settings on the bungee straps may be tightened to create a taut fit.

Beginning at the top of the DOOR SIDE END BLANKET WITH DOOR HANDLE "N", attach the shorter, top-most bungee strap to the corresponding set screw located on the top-most COMPLETED SIDE BRACE located in Section 3 of the bale blind frame, as illustrated in Figure 32.1. Next attach the longest bungee strap to the corresponding set screw located on COMPLETED VERTICAL BRACE, as illustrated in 32.1. Working downward following around the perimeter of the end hoop, attach each bungee strap to it's corresponding set screw on the bale blind frame, as illustrated in Figure 32.1. Once you have attached each bungee strap in its location, go back through and tighten any bungee strap location that may require more tension.

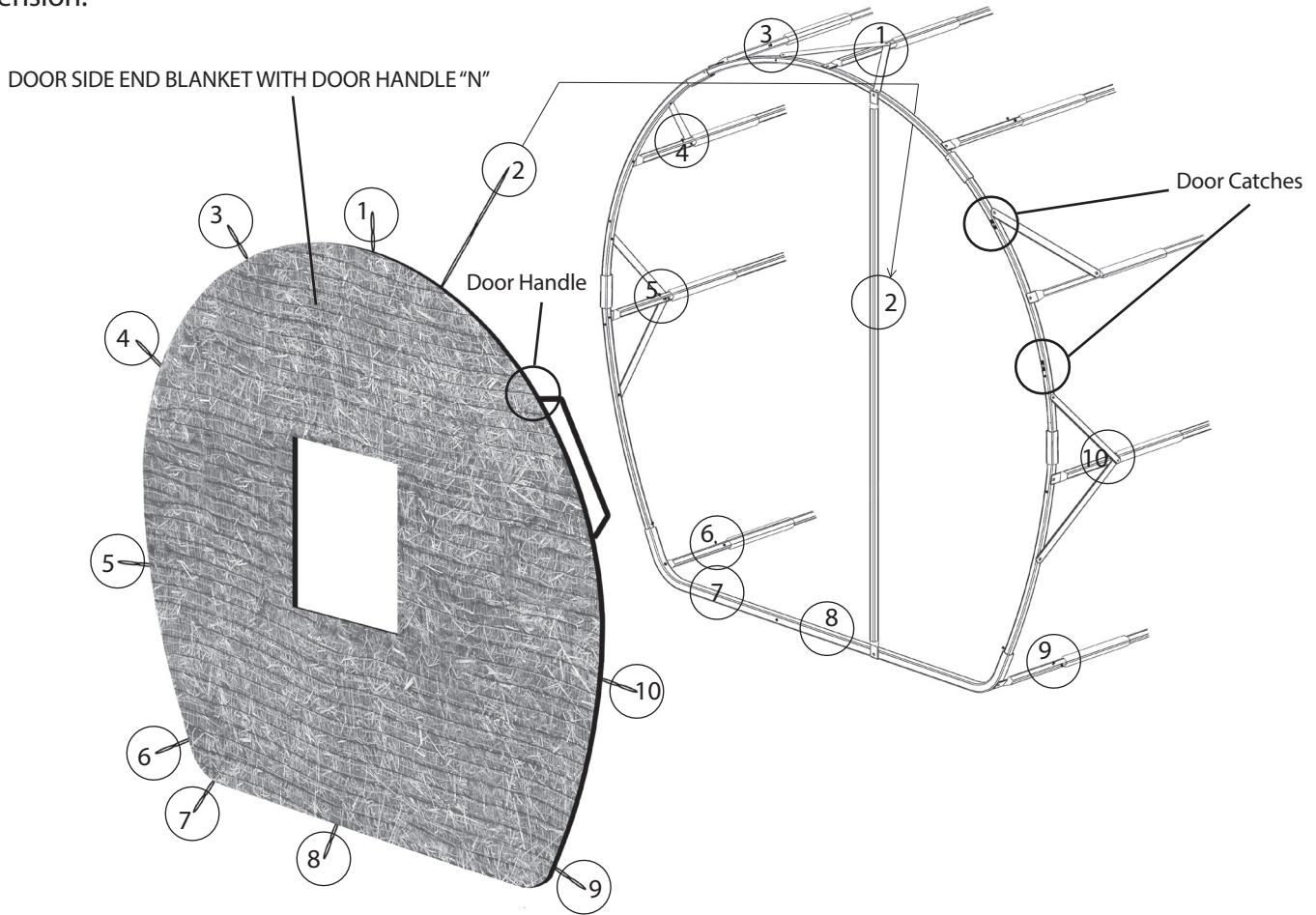

Figure 32.1

STEP 25: Locate the (1) END BLANKET "O" that will be installed on the other end hoop. Repeat Step 24 for the opposing end, attaching each bungee strap to it's corresponding set screw location, starting at the top and working downward following around the perimeter of the end hoop, as illustrated in Figure 33.1.

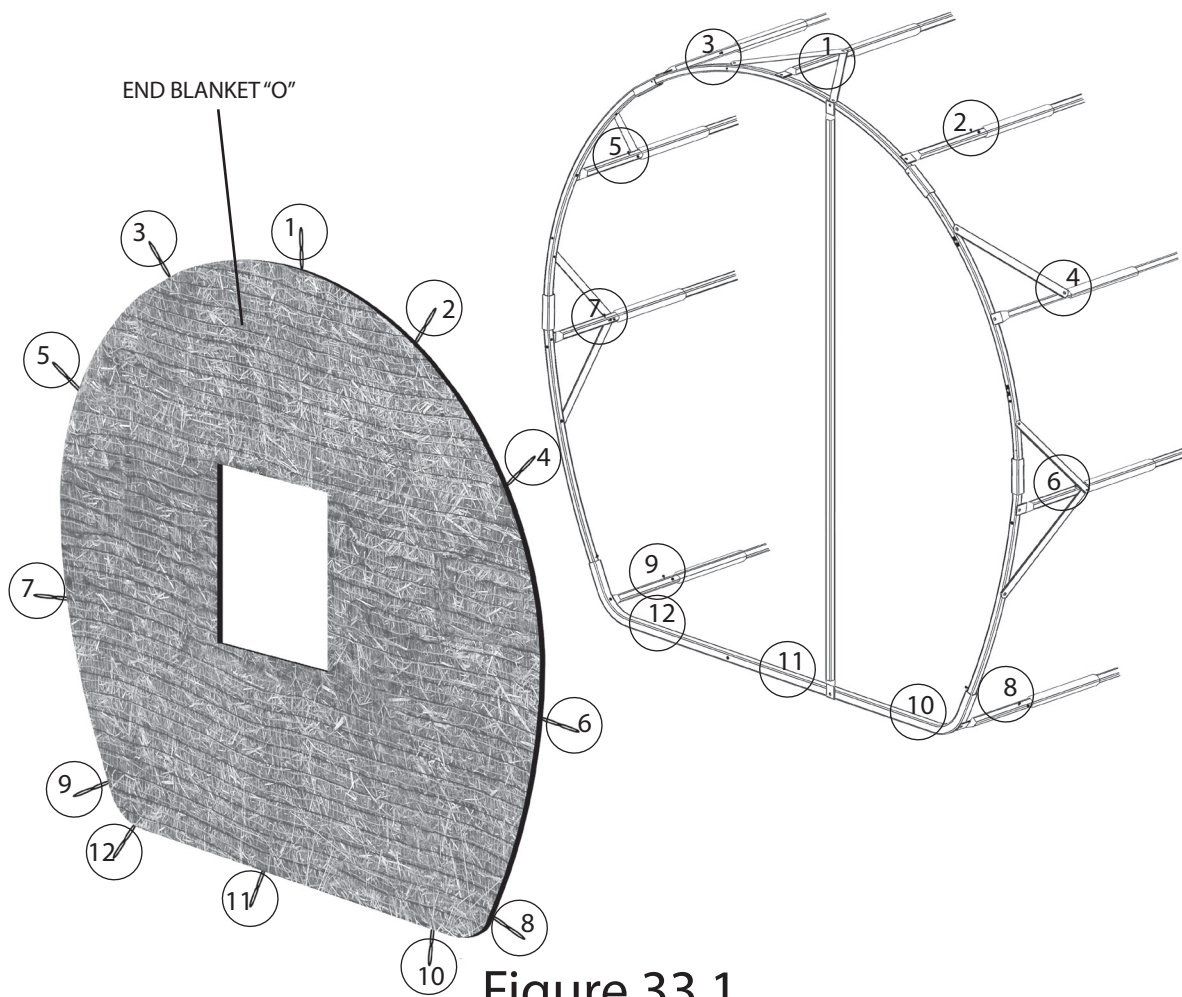

Figure 33.1

You should now have a both End Blankets installed, resulting in the frame illustrated in Figure 34.1.

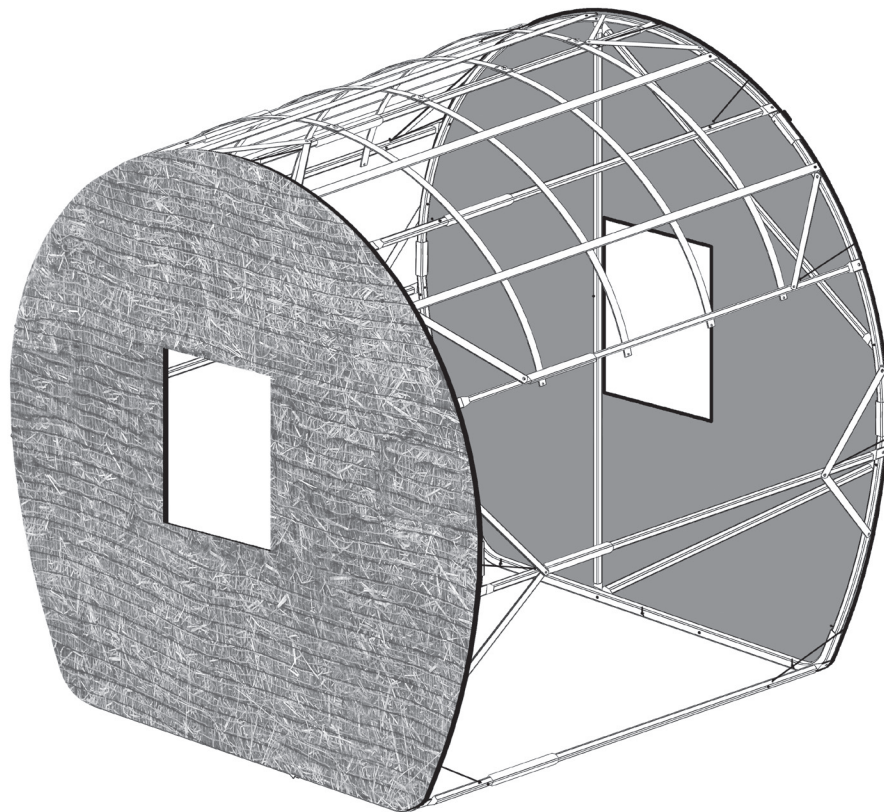

Figure 34.1

STEP 26: Locate the (1) COVER BLANKET “P” that will be installed over the remaining bale blind frame. Keeping the COVER BLANKET “P” rolled-up in it’s double curl configuration, place it on top of the bale blind frame at the center-most COMPLETED SIDE BRACE , as illustrated in Figure 35.1. Then simply unroll each end, allowing the COVER BLANKET “P” to lay over the frame.

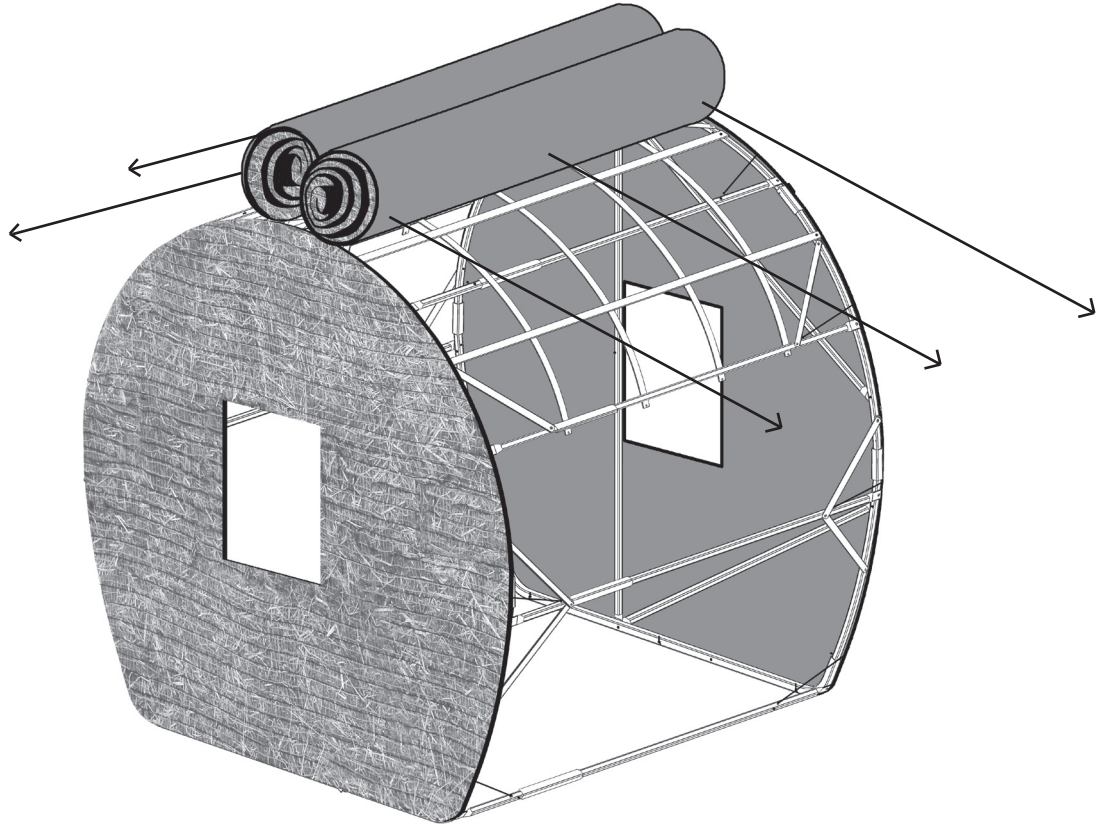

Figure 35.1

STEP 27: With the COVER BLANKET “P” still loosely laying over the bale blind frame, get inside the bale blind frame. The remainder of the assembly process will be performed from the interior of the bale blind. Locate the (4) bungee straps positioned along the bottom of one end of the COVER BLANKET “P”. Attach each bungee strap to it’s corresponding set screw located on the bale blind frame, as illustrated in Figure 36.1.

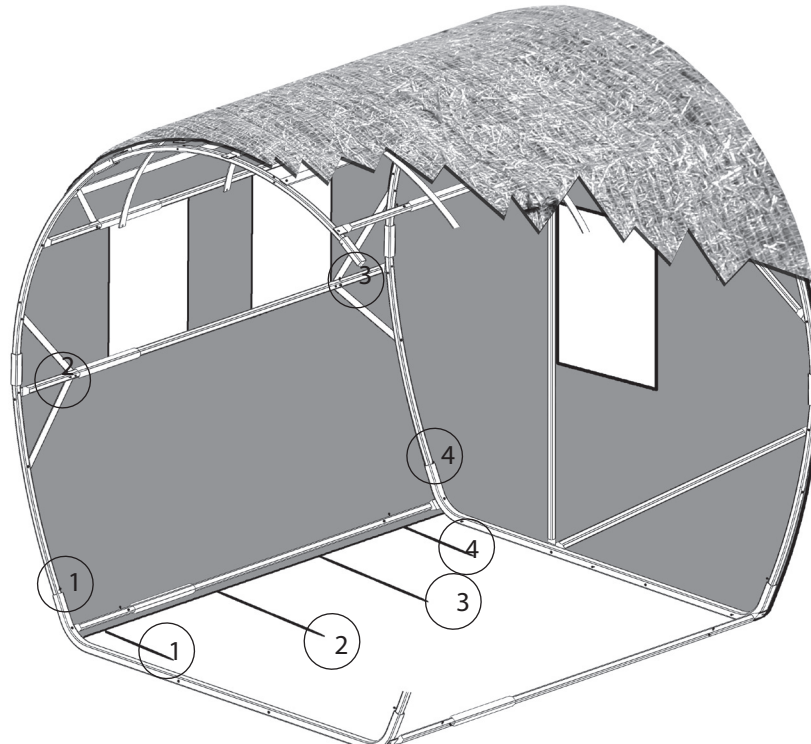

Figure 36.1

STEP 28: Repeat Step 25 for the opposing bottom end of the COVER BLANKET "P". Attach each bungee strap to it's corresponding set screw located on the bale blind frame. The COVER BLANKET "P" should now be completely installed and secured to the bale blind frame.

STEP 29: Locate (2) SILENT SLIDE WINDOW COVERS "Q" to be installed for the shooting window openings located on each end hoop . Starting at the top, attach each clip to the END FRAME TOP HOOP "H" , then repeat the process for the bottom clips, attaching to the END FRAME BOTTOM HOOP "M" , as illustrated in Figure 37.1. Perform this step for both SILENT SLIDE WINDOW COVERS "Q" to be installed on the end hoops.

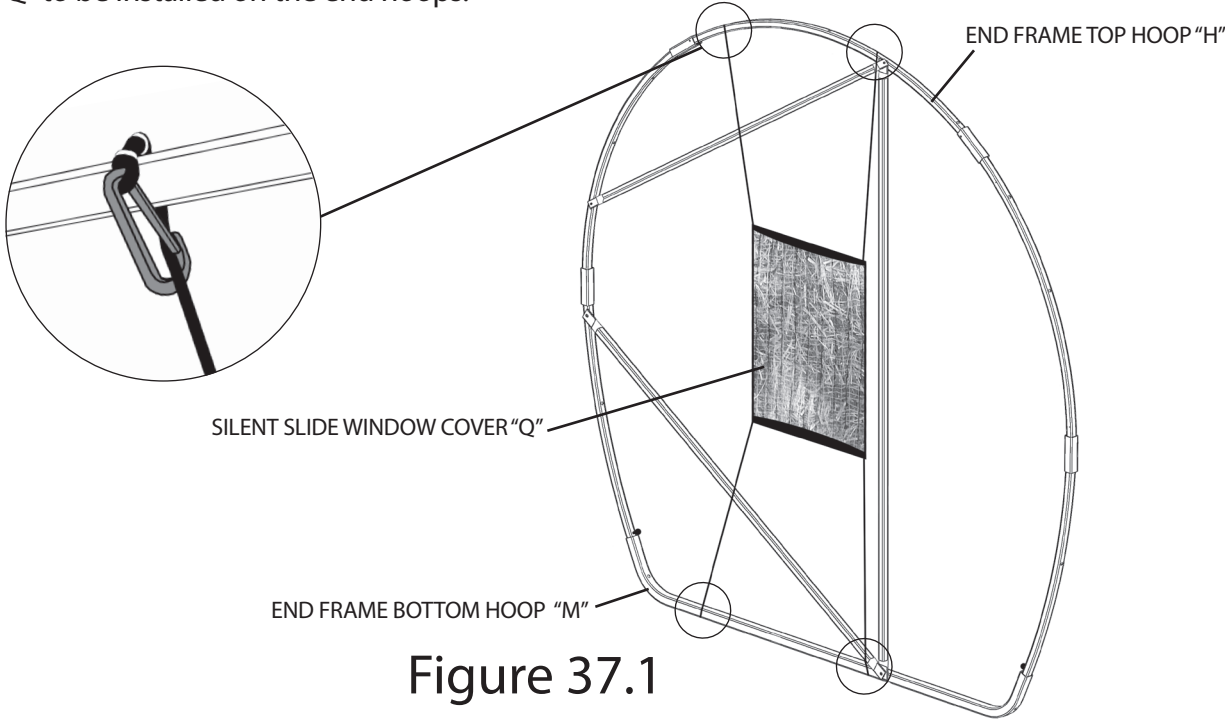

Figure 37.1

STEP 30: Locate the remaining (4) SILENT SLIDE WINDOW COVERS "Q" to be installed for the shooting window openings located on COVER BLANKET "P". Starting at the top, attach each clip to the COMPLETED SIDE BRACE, then repeat the process for the bottom clips, attaching to the bottom COMPLETED SIDE BRACE located on the base of the frame, as illustrated in Figure 38.1. Perform this step for the remaining (4) SILENT SLIDE WINDOW COVERS "Q" to be installed for the window openings on the COVER BLANKET "P".

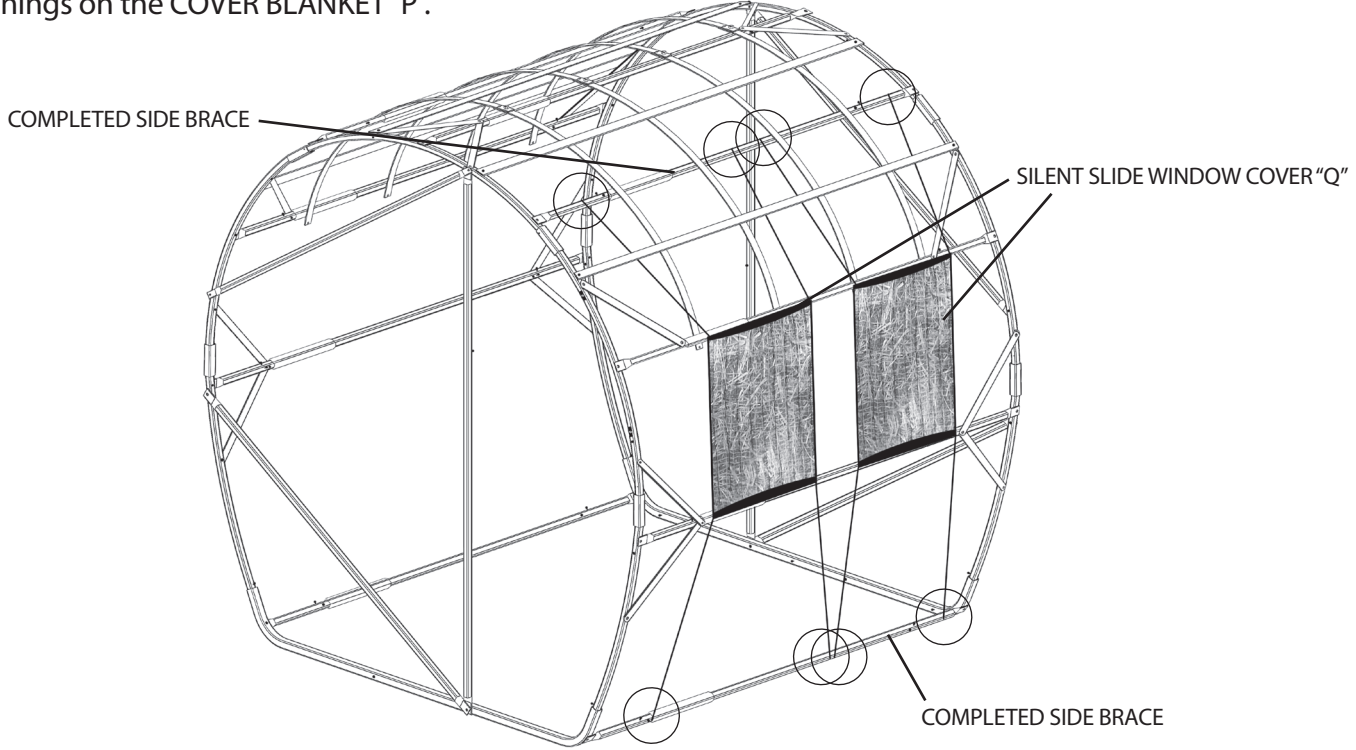

Figure 38.1

Your Redneck Outfitter Bale Blind should now be completely assembled. Should you have any questions about the assembly, installation or use of this product, or any other Redneck Outdoor product, please call one of our customer service representatives toll free at 877-523-9986.

ANCHORING YOUR BLIND TO THE GROUND: Locate the (1) REBAR ANCHOR STAKE & the (1) HOLD-DOWN ANCHOR BRACKET. On one of the sides of the blind frame, using a Large Hammer / Sledge, drive the REBAR ANCHOR STAKE through the HOLD-DOWN ANCHOR BRACKET, making sure the HOLD-DOWN ANCHOR BRACKET is securely placed over the LOWER FRAME , as illustrated in Figure 39.1.

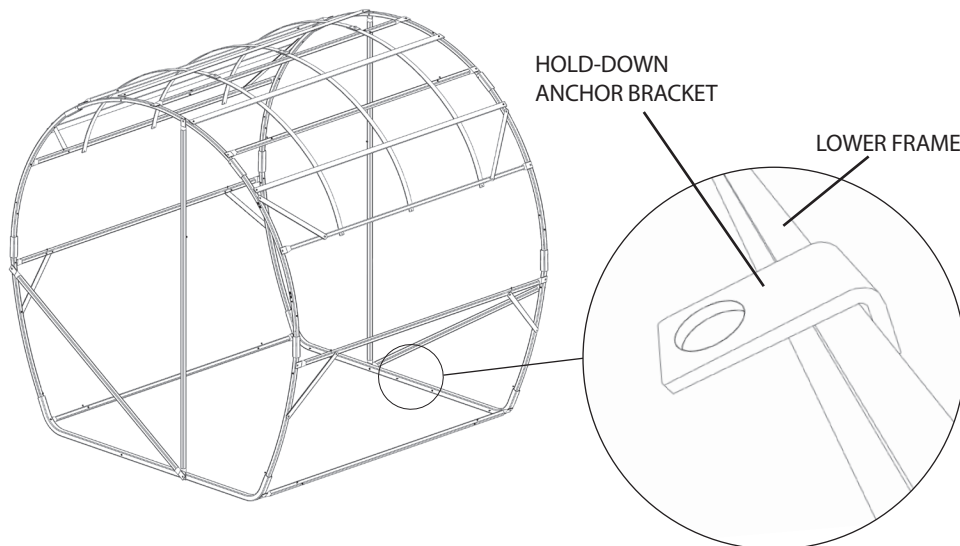

Figure 39.1

BILL OF MATERIALS

PARTS LIST



"B" END FRAME VERTICAL BRACE (2) - 66" Length



"BB" END FRAME VERTICAL BRACE EXTENSION (2) - 12" Length

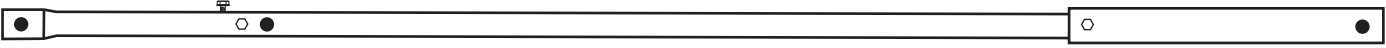

"C" LOWER WINDOW BRACE (2) - 60" Length



"CC" LOWER WINDOW BRACE EXTENSION (2) - 18" Length



"EE" SIDE BRACE EXTENSION (7) - 18" Length

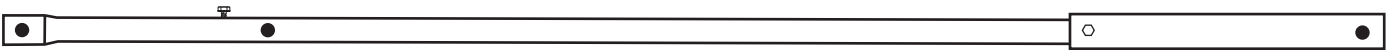

"E" SIDE BRACE (7) - 60" Length

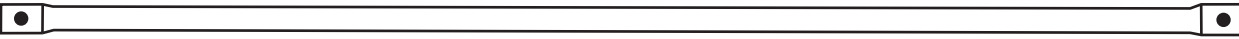

"F" END FRAME CROSS BRACE (4) - 52" Length

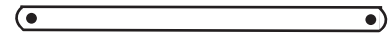

"G" CROSS MEMBER BRACE (16) - 15" Length

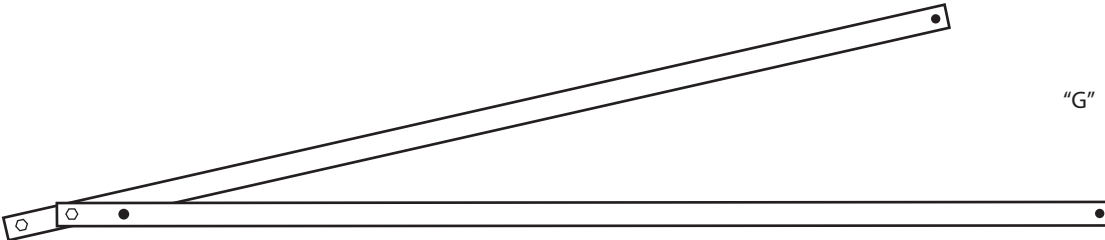

"L" TOP CROSS BRACE (4)

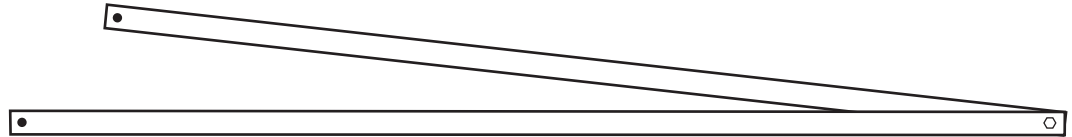

"Z" TOP BLANKET SUPPORT (4)

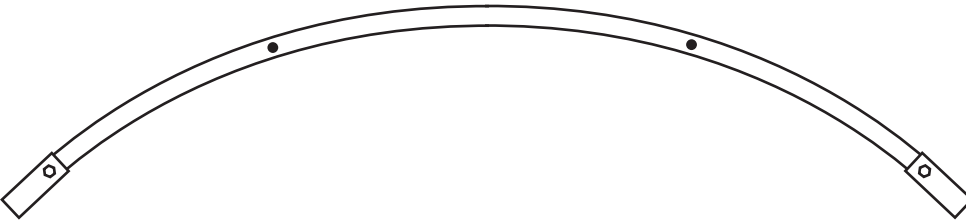

"H" END FRAME TOP HOOP (2)

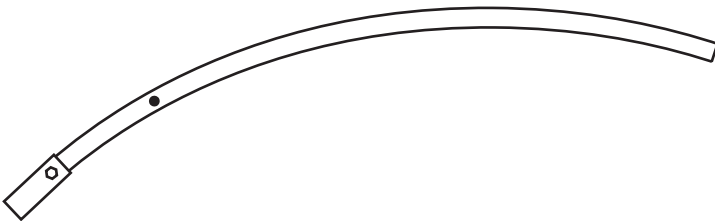

"J" END FRAME UPPER SIDE HOOP (3)



"I" END FRAME UPPER SIDE HOOP WITH DOOR CATCHES (1)

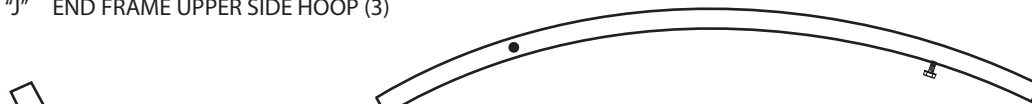

"K" END FRAME LOWER SIDE HOOP (4)

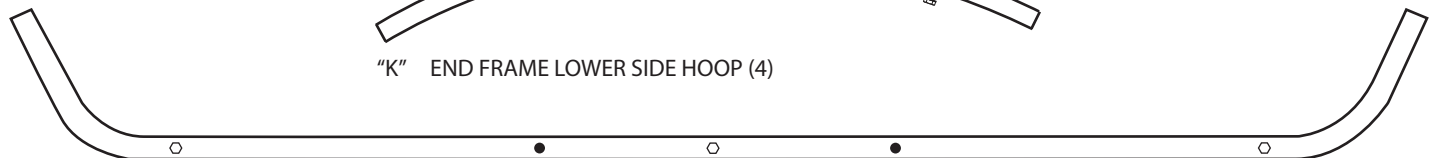

"M" END FRAME BOTTOM HOOP (2)

BILL OF MATERIALS

BALE BLANKETS & WINDOW COVERS

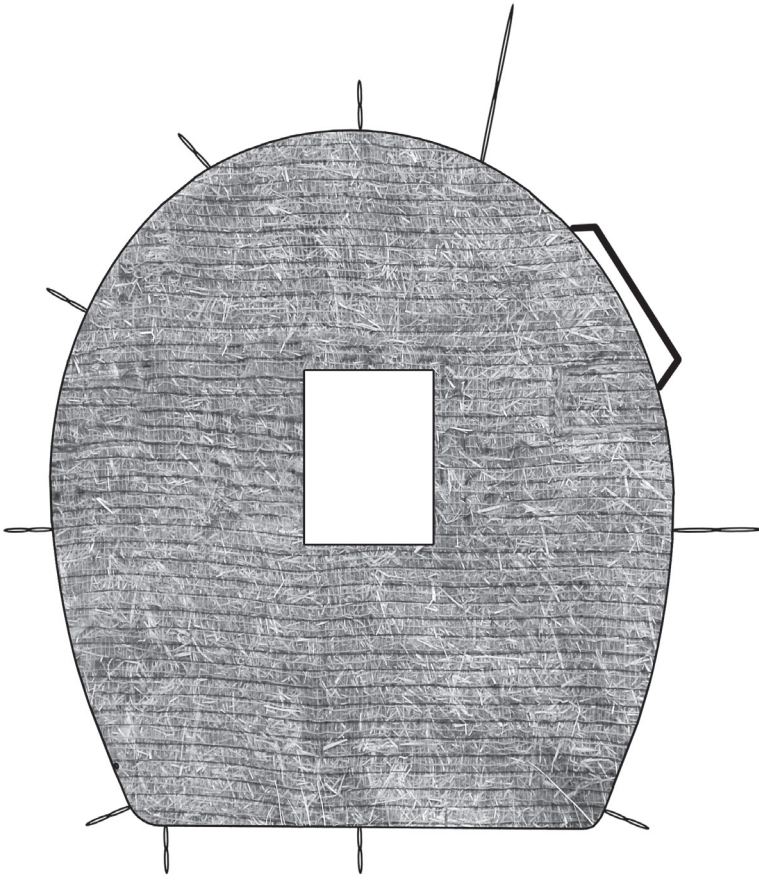

"N" DOOR SIDE END BLANKET WITH DOOR HANDLE (1)

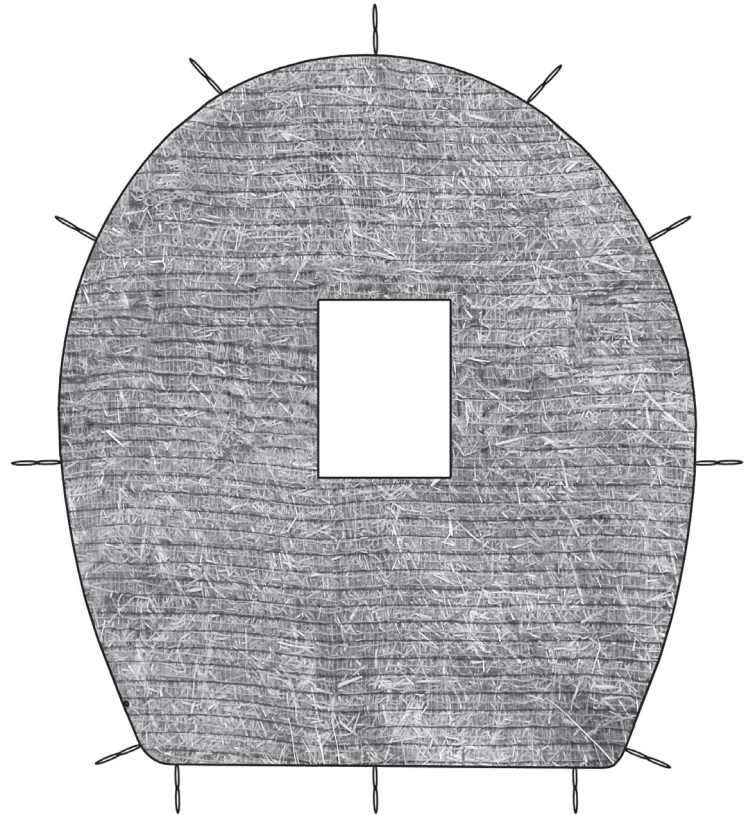

"O" END BLANKET (1)

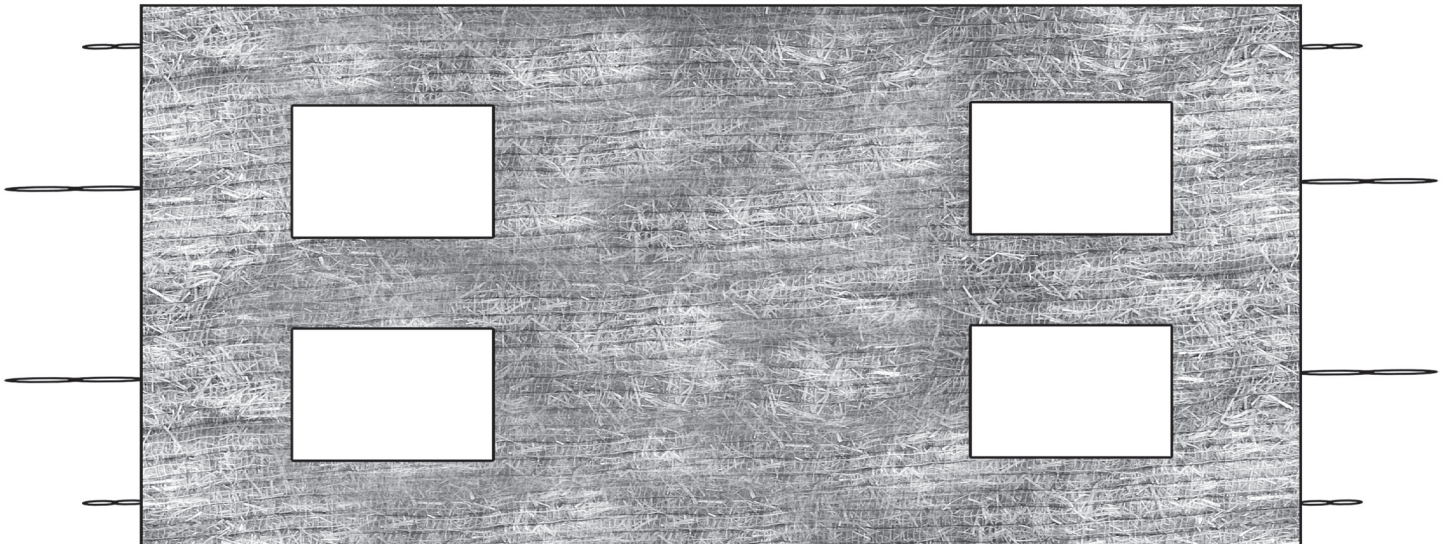

"P" COVER BLANKET (1)

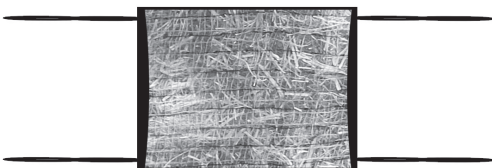

"Q" SILENT SLIDE WINDOW COVER (6)

BILL OF MATERIALS

HARDWARE

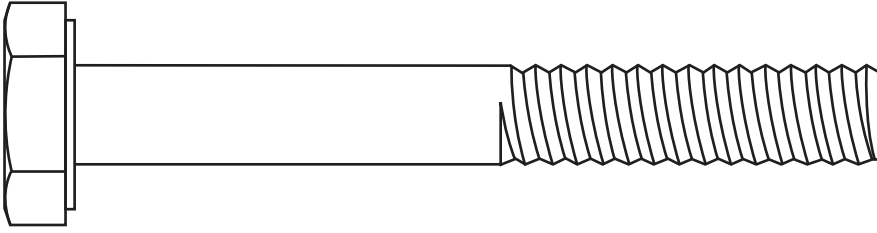

2" Bolts (2)

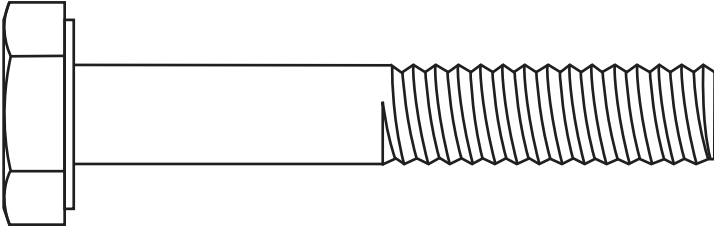

1.5" Bolts (15)

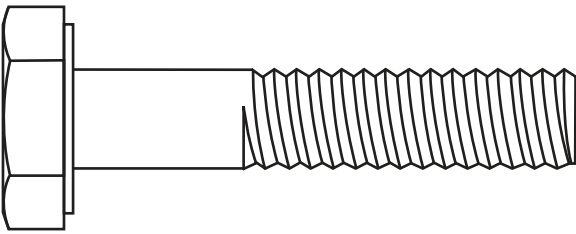

1.25" Bolts (41)



Nuts (57)



Wing Nut (1)



Rebar Stake (1)

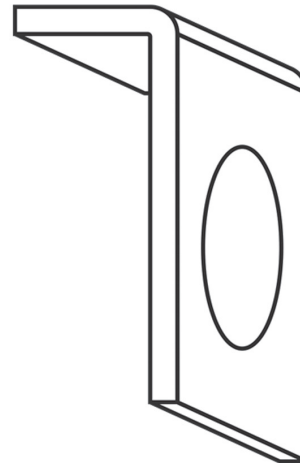

Hold Down Anchor Bracket (1)

Zip-Ties (32)

TOOLS REQUIRED FOR ASSEMBLY (NOT INCLUDED)

- Tape Measure
- Wrench(s) Size: 7/16 & Size: 5/16
- Hammer