



REDNECK PORTABLE DUCK BLIND ASSEMBLY INSTRUCTIONS

READ THESE INSTRUCTIONS IN THEIR ENTIRETY PRIOR TO ASSEMBLING THIS PRODUCT

WARNING! Do not remove, modify and/or omit any portion or otherwise mechanically modify this product(s) or its assemblies in any manner. Modification, misuse and/or part substitution shall immediately void your factory warranty. If you suspect that a part(s) is missing and/or defective, immediately discontinue all use of the product and contact Redneck Manufacturing at 877-523-9986 for replacement of missing or defective parts.

NOTE: Some parts of this product are manufactured to be universal in use, so there may be some parts containing holes that will not be used in the assembly of this particular model. To minimize confusion in the assembly process, please read these instructions in their entirety before beginning.

Should you have any questions about the assembly, installation or use of this product, or any other Redneck Outdoor product, please call one of our customer service representatives toll free at 877-523-9986.

NOTE: REMOVE COVER DURING OFF SEASON. Redneck Blinds strongly recommends removing your Duck Blind Cover when hunting season is over. This will help prolong the life of the cover by preventing sun fading, rodent damage, and tattering from strong winds. **READ THESE INSTRUCTIONS IN THEIR ENTIRETY PRIOR TO ASSEMBLING THIS PRODUCT**

-----BILL OF MATERIALS-----

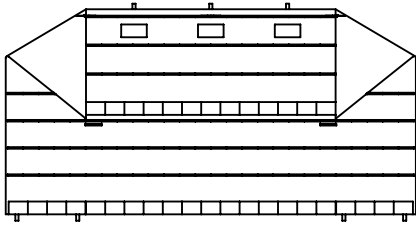

"J" FRONT COVER (1)

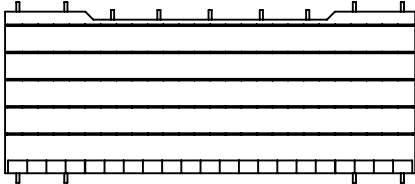

"K" BACK COVER (1)

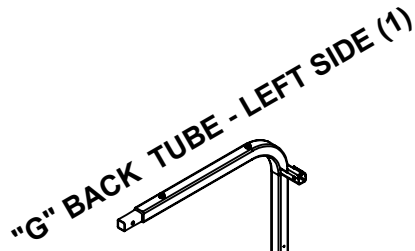

"G" BACK TUBE - LEFT SIDE (1)

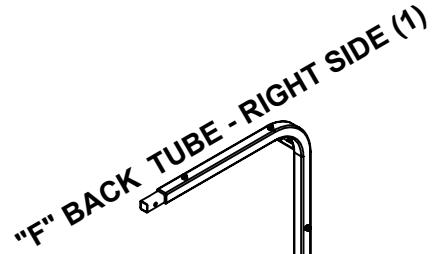

"F" BACK TUBE - RIGHT SIDE (1)

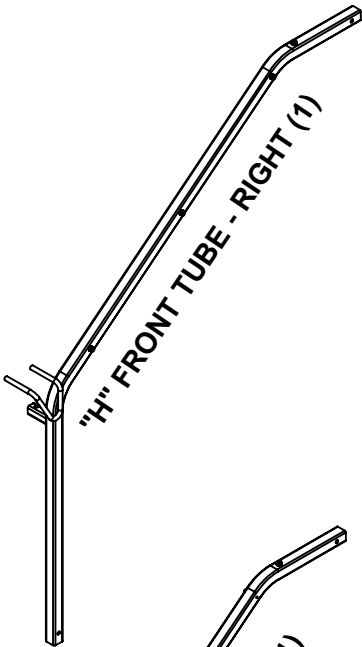

"H" FRONT TUBE - RIGHT (1)

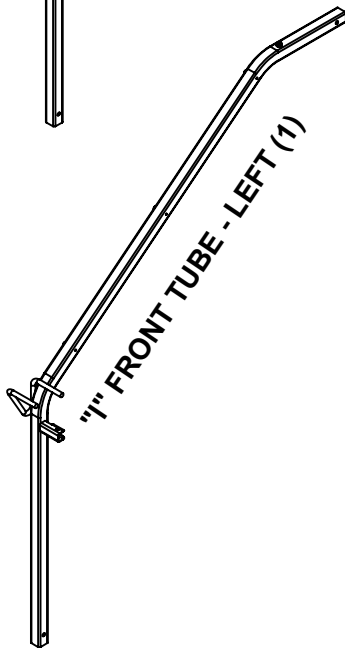

"I" FRONT TUBE - LEFT (1)

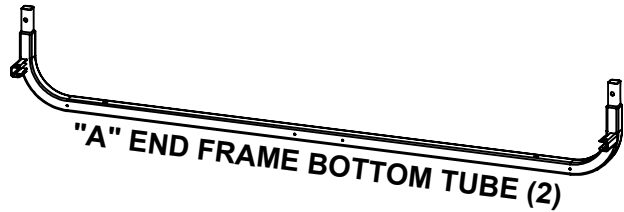

"A" END FRAME BOTTOM TUBE (2)

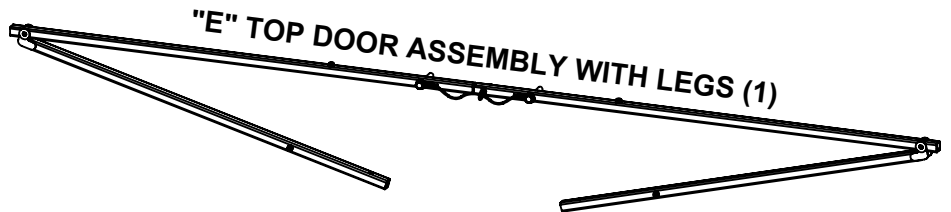

"E" TOP DOOR ASSEMBLY WITH LEGS (1)



"D" BOTTOM DOOR ASSEMBLY (1)

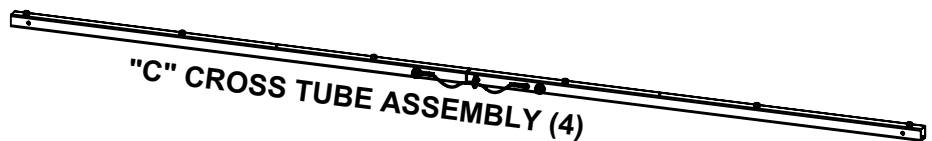

"C" CROSS TUBE ASSEMBLY (4)

STEP 1: Remove all parts from the packaging and familiarize yourself with them. Find the bill of material located on the second page of this manual and verify that all parts are present. You will not need any tools for assembling this duck blind.

STEP 2: Take all the cross tube assemblies, part part "C", and snap them together, see figure 10.1. Each tube assembly should be connected by a cable to keep the male and female parts together. Once the tubes are slid together insert the push pin as shown in figure 10.3. Making sure the pin goes through both sides of the tube.

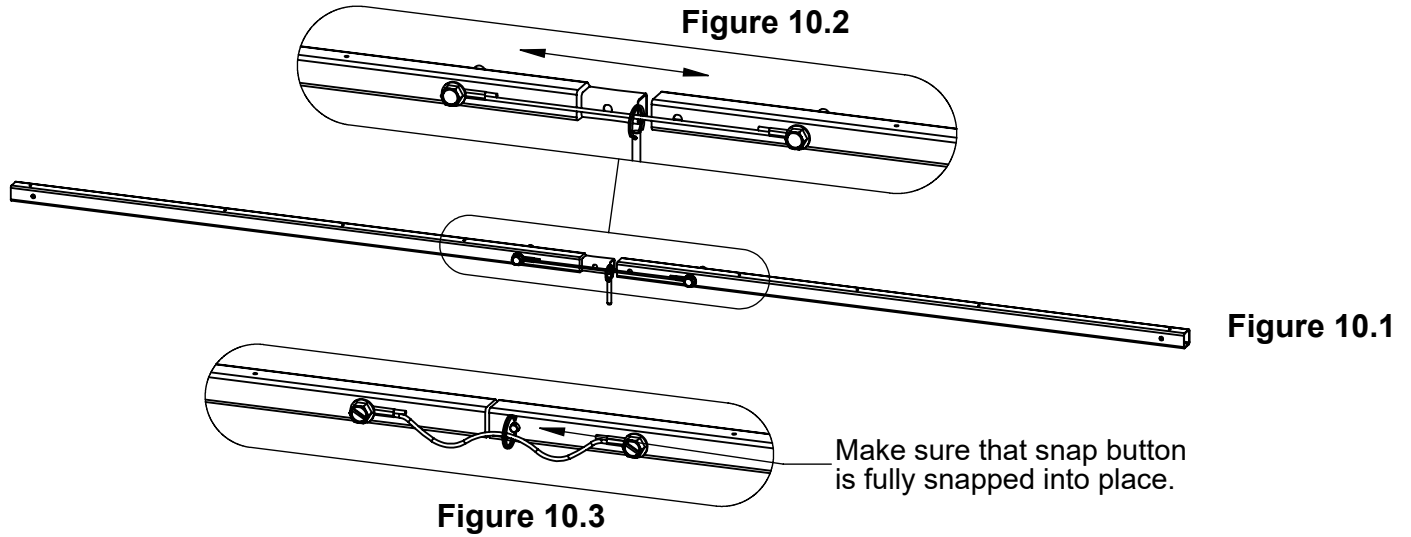

STEP 3: Locate both end frame bottom tube part "A" and lay them on the ground arms width apart, making sure that the lugs on both parts are facing inwards. Then take two of cross tube assembly "C" and connect both end frame bottom tubes together. Once the tubes are slid together insert the push pin as shown in figure 11.2. Making sure the pin goes through both sides of the tube.

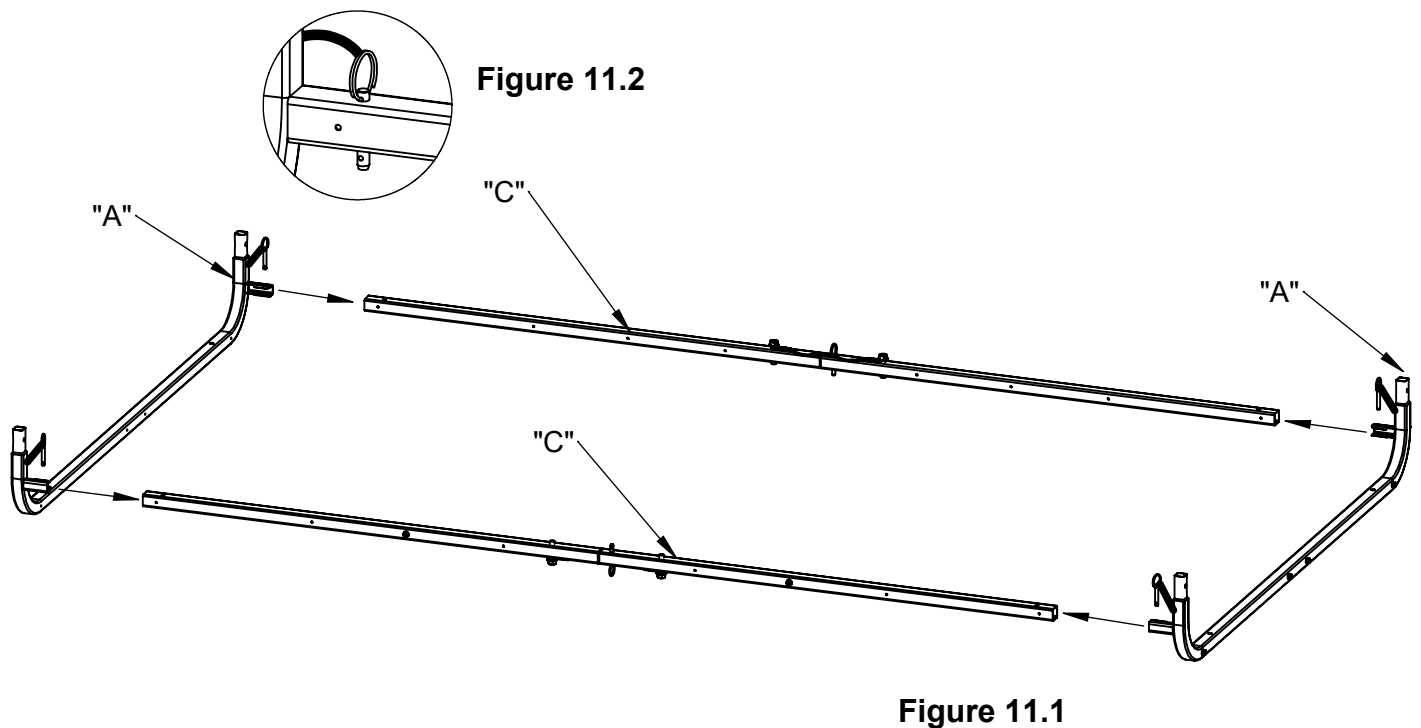

STEP 4: Take parts "G" & "I" and connect them together at the top, securing together with the connected push pin. Once connected at the top, place them onto the two stems sticking up on the bottom end frame tube, see figure 12.1. Again making sure that the lugs are facing inward toward the blind. Once the tubes are slid together insert the push pin as shown in figure 12.3. Once the left side is done take parts "F" & "H" and repeat to finish the right side, figure 12.2.

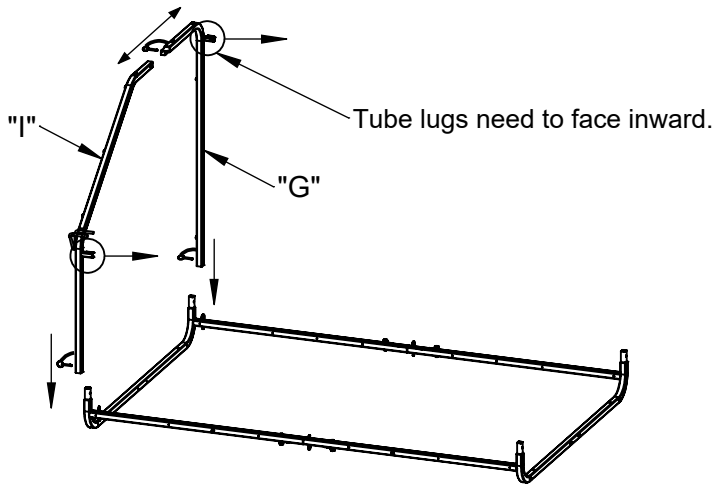

Figure 12.1

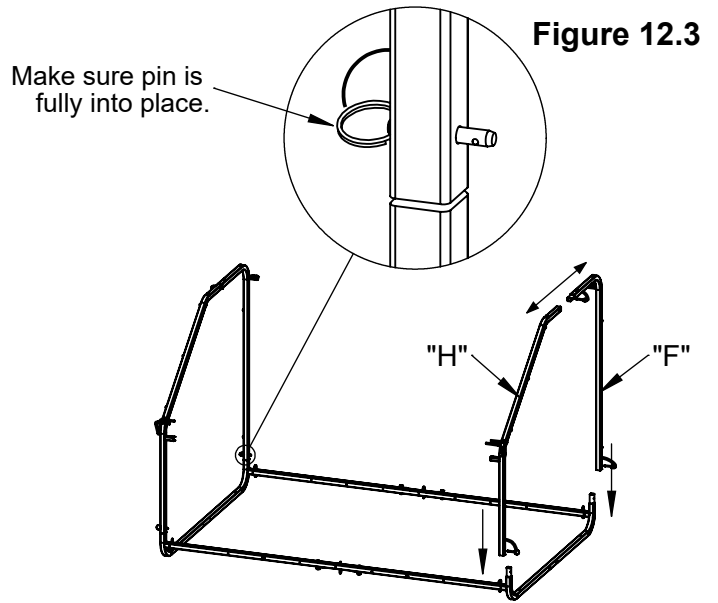

Figure 12.2

STEP 5: Take Cross tube assembly "C" and install onto the top lugs on the back side of the frame. Install one end onto the tube lug on the right or left side of the frame, figure 13.1. Once the tube assembly is fully installed and pinned into place on one end move the tube to where you can slide the lug into the free end on the opposite side. You will have to tilt the end frame out of the way slightly to let the lug clear the tube and slide inside it, refer to figure 13.3. Once tube lug is fully inserted into the tube pin it into place.

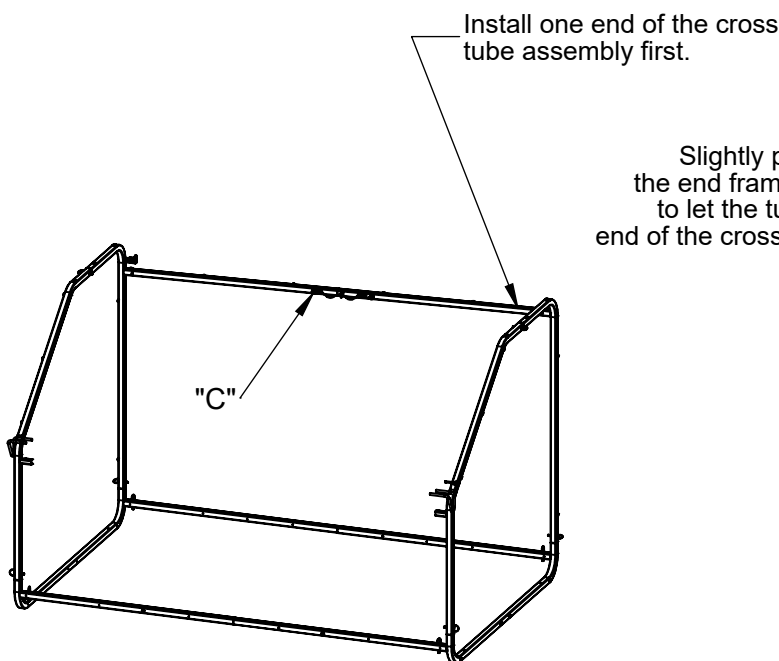

Figure 13.1

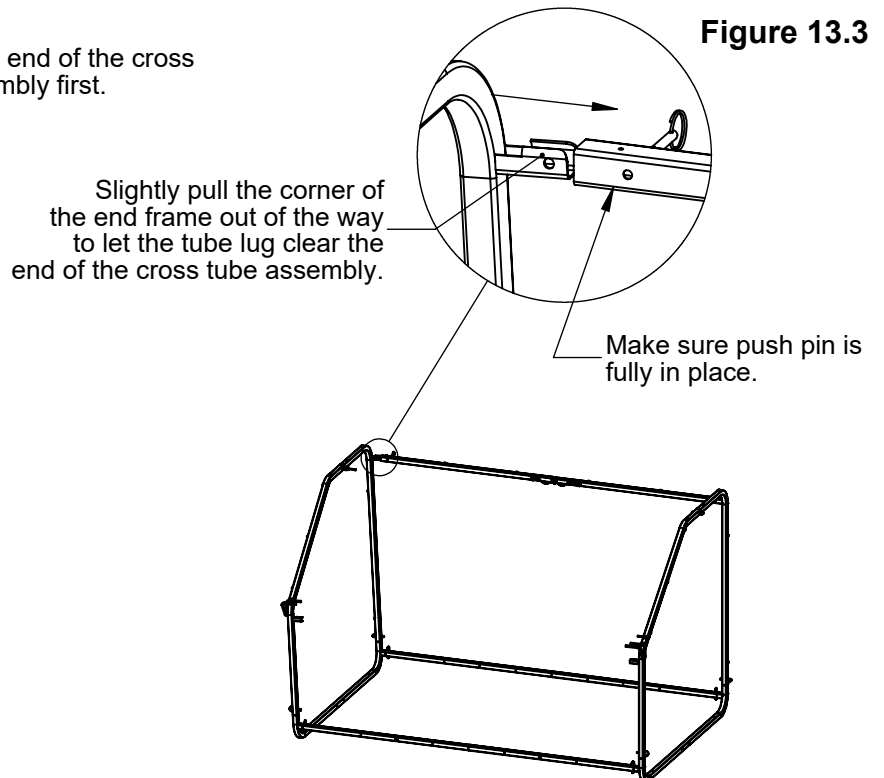

Figure 13.2

STEP 6: Attach one end of Cross tube assembly "C" at the right or left side of the frame, see figure 14.3. Then locate Bottom door assembly "D" and snap together, making sure that both tube lugs are facing the same direction, refer to Figures 15.2 & 15.3 at the bottom of the page. Once tube is snapped together place end over the wire closest to the frame, the wire without a rubber coating, figure 14.3. Once both tubes are in place on one end, swing the tubes up and slide into place on the other side. Pull the end frame away slightly so the tubes will clear the wire and tube lug, see figure 14.4. Slide the door frame end over the wire first, then place the cross tube assembly over the lug second. Once tube lug is fully inserted into the tube make sure it is pinned into place.

Figure 14.3

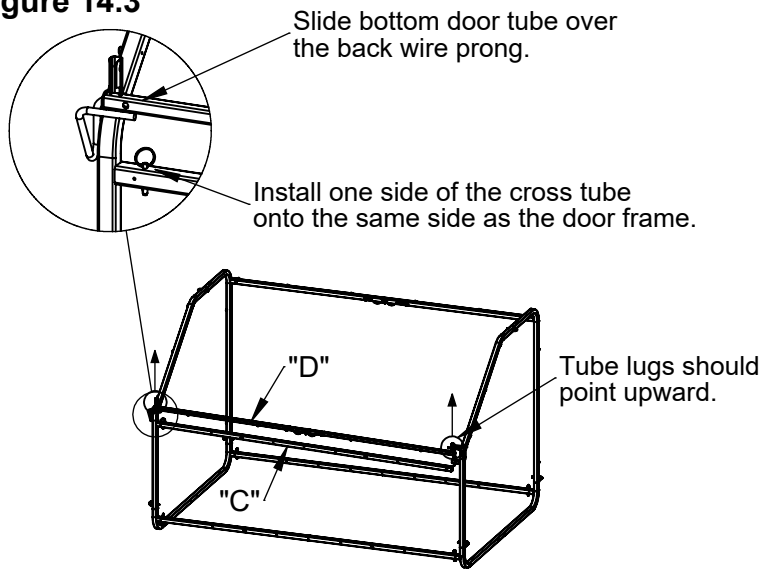

Figure 14.1

Figure 14.4

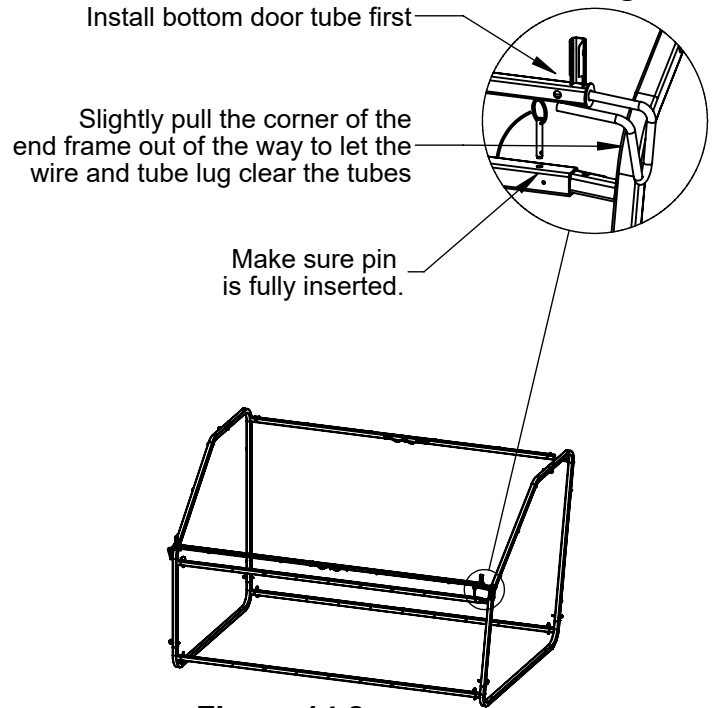

Figure 14.2

STEP 7: Find the top door assembly with legs "E", and connect the middle section together making sure that both legs are facing the same direction, figures 15.2 & 15.3. Once the middle section is snapped together, fold the legs on both ends down and slide them over the tube lugs on the bottom door assembly "D".

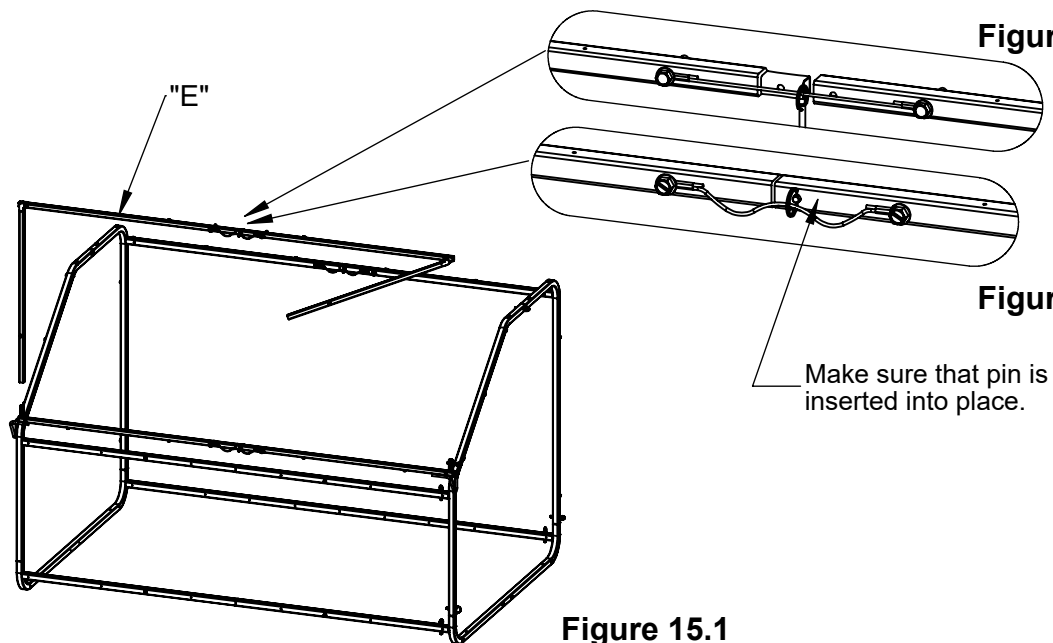

Figure 15.1

STEP 8: When installing the cover it is easiest to start with front cover "J". Start by sliding the top corner pockets over the top of the door frame, then hook the buckles on the cover to the top side of the door frame, as shown in figure 16.1& 17.3. Once the top of the cover is buckled into place, secure the rest of the door cover in place with the velcro straps and buckles. Once the door is secured insert the wire door stops on the front of the frame through the slots on the cover, figure 16.3.

Slide the corner of the door frame into the corner pocket on both sides of the front cover.

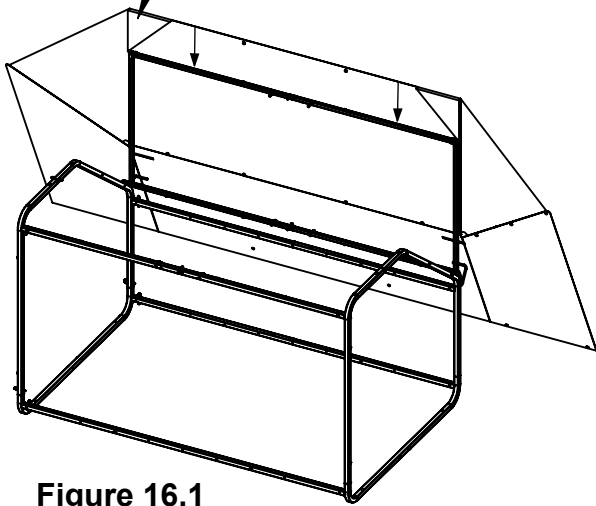

Figure 16.1

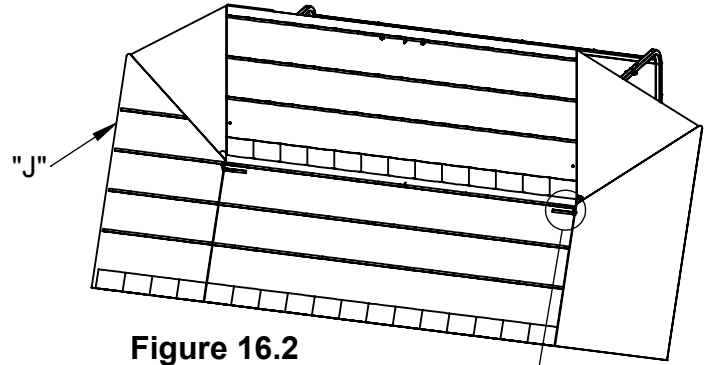

Figure 16.2

Figure 16.3

Slide the wire door stop through the slot in the front cover.

STEP 9: Once the door cover is in place and the door stop is through the cover slot, start securing the rest of the cover into place. Easiest to start at the bottom of the front and work your way around to the ends. You may want to position your door closed to allow a little slack in the cover while securing buckles into place. The front cover has (15)nylon straps with buckles to secure into place. Wrap them around the tube and the adjust the nylon strap to tighten to the frame. There is also velcro straps in places to secure the cover, see figure 17.2, on how to attach.

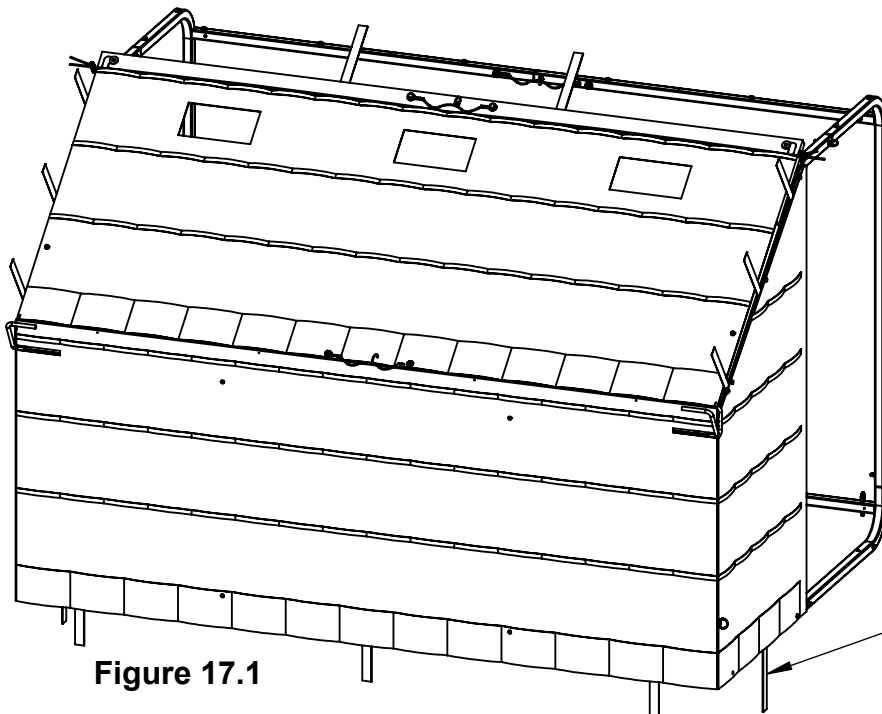
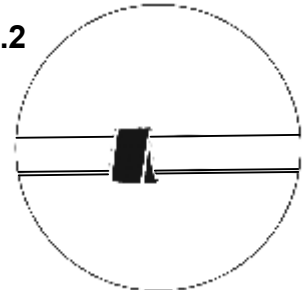

Figure 17.1

Figure 17.2



Velcro straps are located on the cover as well as snaps. Velcro straps can be used in place of snaps or with snaps for the most cover support. Wrap the Velcro around the tube frame and hook it to itself to secure it.



Figure 17.3

STEP 10: When installing the back cover it is easiest to start at one end of the blind and wrap the cover around the back side of the blind and finish on the opposite end. When starting, connect the (3) buckles where the covers meet and then start to wrap the cover around the frame, see figures 18.1 & 18.3. There is a total of (14) buckles that connect to the frame and (6) buckles that connect the covers together, (3) on each end.



Figure 18.3

Figure 18.1

Figure 18.2

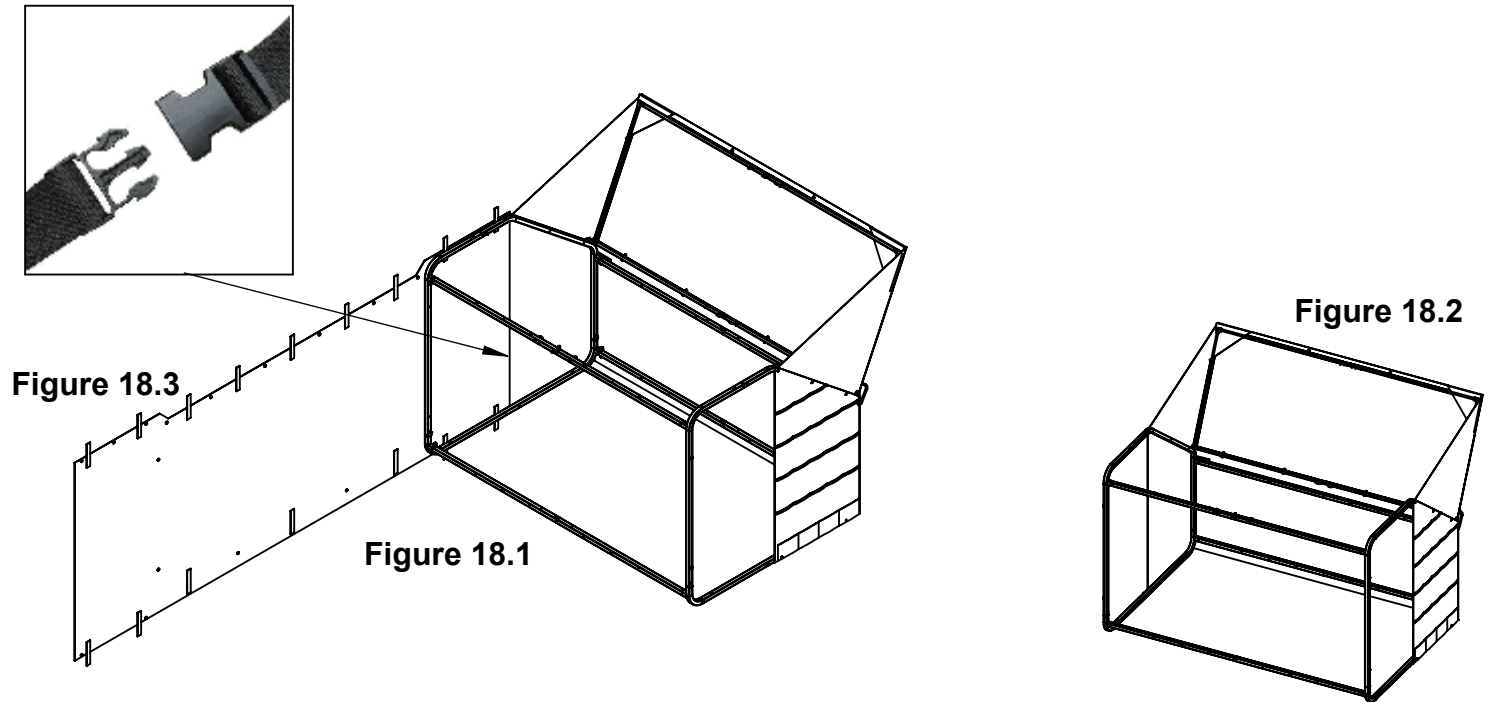

STEP 11: Once the blind is fully assembled and the cover is installed then you can start to brush in the blind. There is a bungee cord along the top of the door to keep brush and other grass in place while throwing the door open. Bungee cords are placed along the top and middle of the back cover as well as the middle of the front cover to help with bigger bundles. Once brush is installed you can pull tight from each end, see figure 19.2.

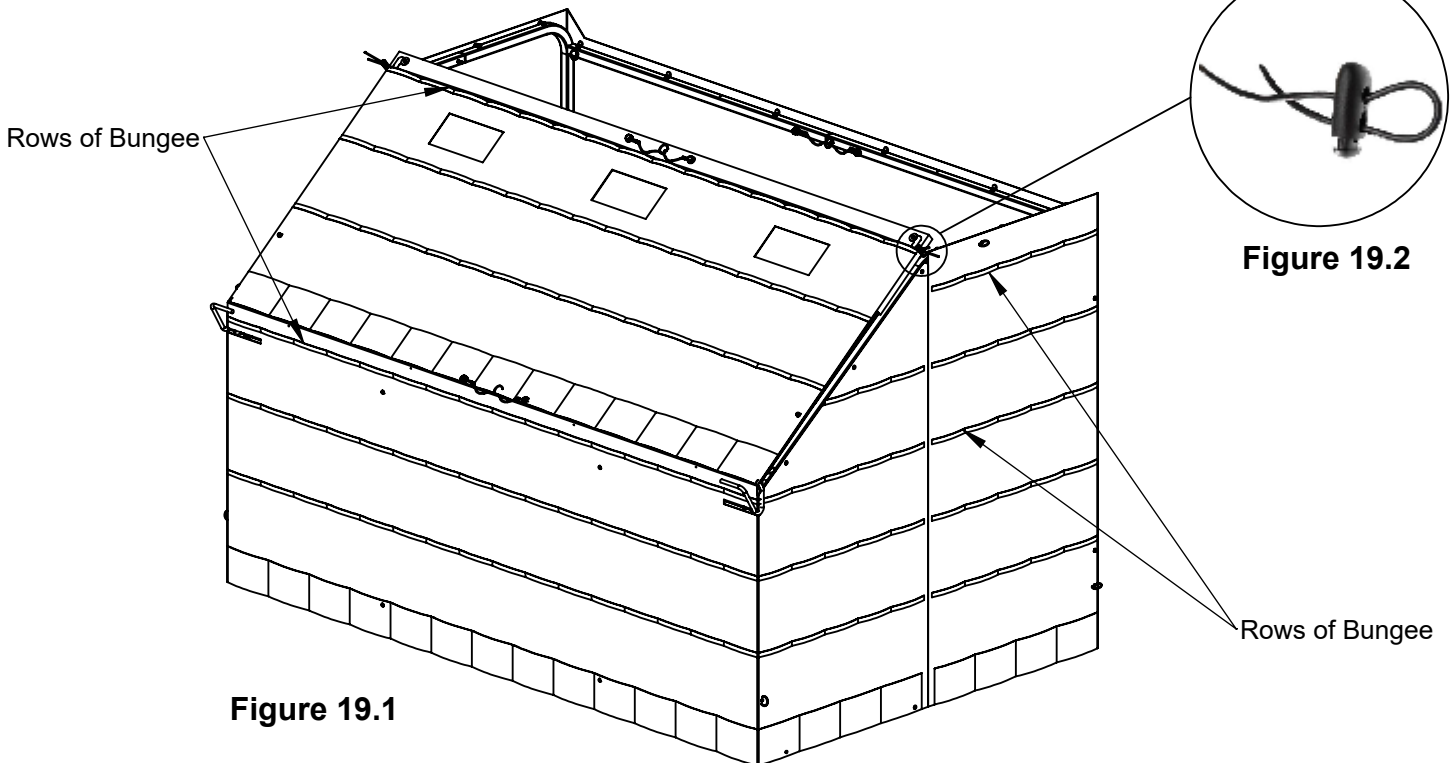
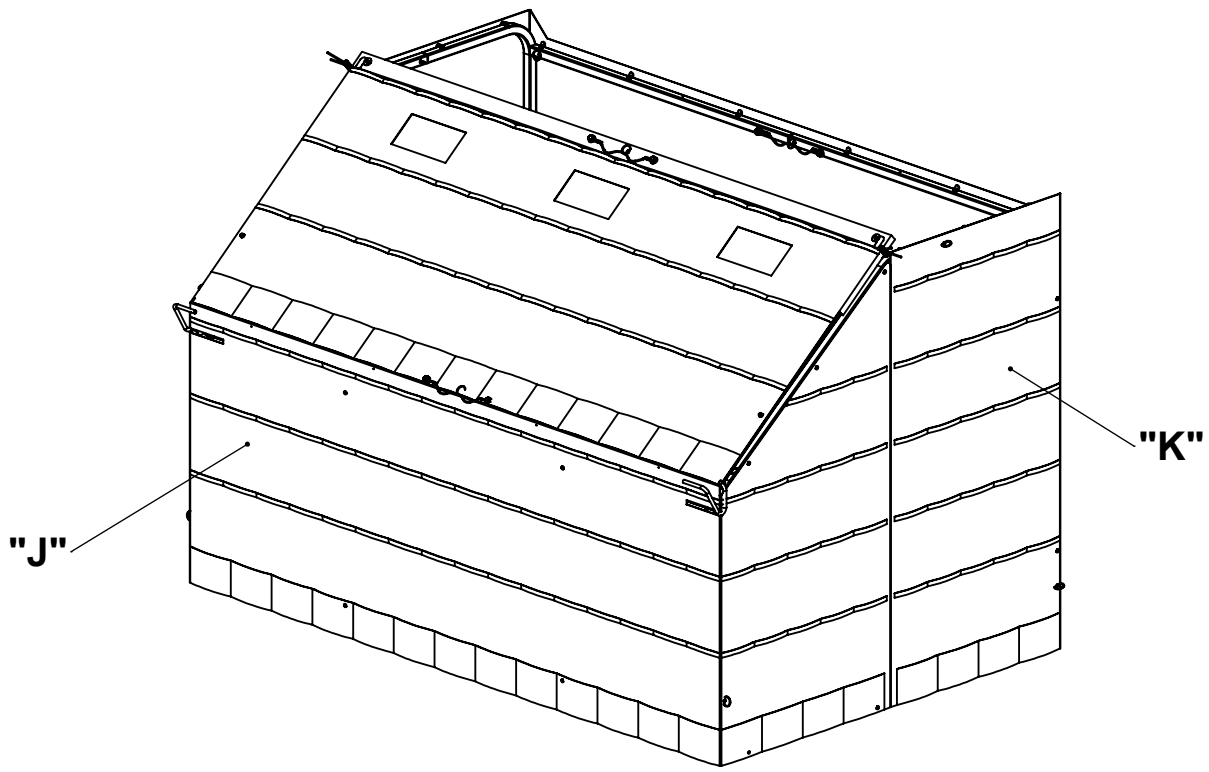
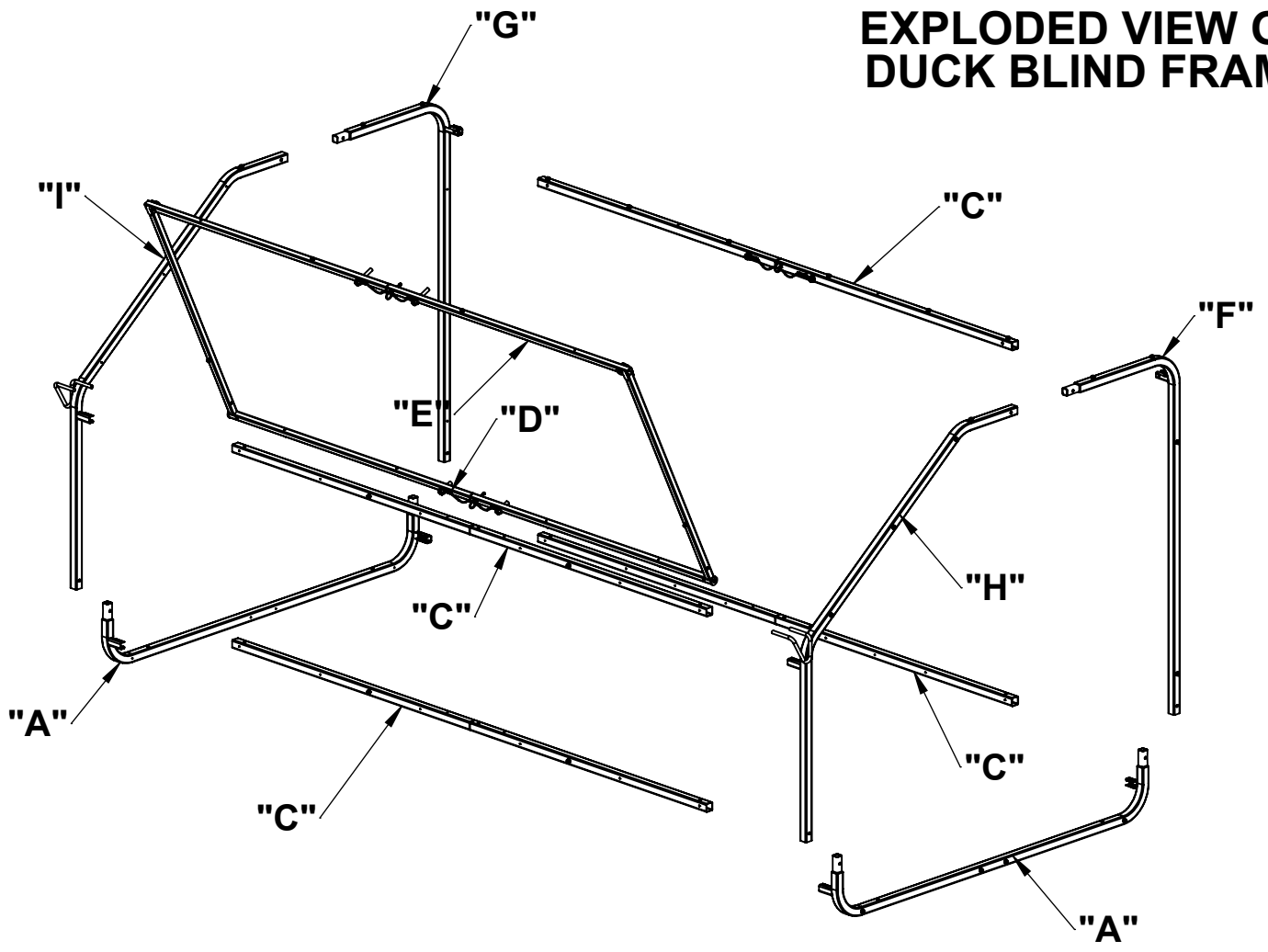

Figure 19.1

Figure 19.2

EXPLODED VIEW OF DUCK BLIND FRAME



OPTIONAL TOP

TOP: We are now including an optional top with our waterfowl blind. If you decide to use this top, you will have to use the kick out door to come out of the blind. When attaching the top there is (7) nylon straps with buckles that attach the top to the frame. Attach both sides of the top to the frame with the (2) straps on each side. Then the (3) straps on one side of the cover are attached to the back cross tube on the frame. There is no buckles on the front side of the cover.

