



## REDNECK BALE BLIND SLED ASSEMBLY INSTRUCTIONS

**READ THESE INSTRUCTIONS IN THEIR ENTIRETY PRIOR TO ASSEMBLING THIS PRODUCT**

**WARNING!** Do not remove, modify and/or omit any portion or otherwise mechanically modify this product(s) or its assemblies in any manner. Modification, misuse and/or part substitution shall immediately void your factory warranty. If you suspect that a part(s) is missing and/or defective, immediately discontinue all use of the product and contact Redneck Outdoor Products at 877-523-9986 for replacement of missing or defective parts.

**WARNING!** This sled is to be used with the Redneck Bale Blinds only. Any modifications to make sled fit any other blinds may result in voiding the warranty.

**NOTE:** Some parts of this product are manufactured to be universal in use, so there may be some parts containing holes that will not be used in the assembly of this particular model. To minimize confusion in the assembly process, please read these instructions in their entirety before beginning.

Should you have any questions about the assembly, installation or use of this product, or any other Redneck Outdoor Products, please call one of our customer service representatives toll free at 877-523-9986.

**NOTE: REMOVE COVER DURING OFF SEASON.** Redneck Blinds strongly recommends removing your Hay Bale Blind Cover when hunting season is over. This will help prolong the life of the cover by preventing sun fading, rodent damage, and tattering from strong winds. **READ THESE INSTRUCTIONS IN THEIR ENTIRETY PRIOR TO ASSEMBLING THIS PRODUCT**

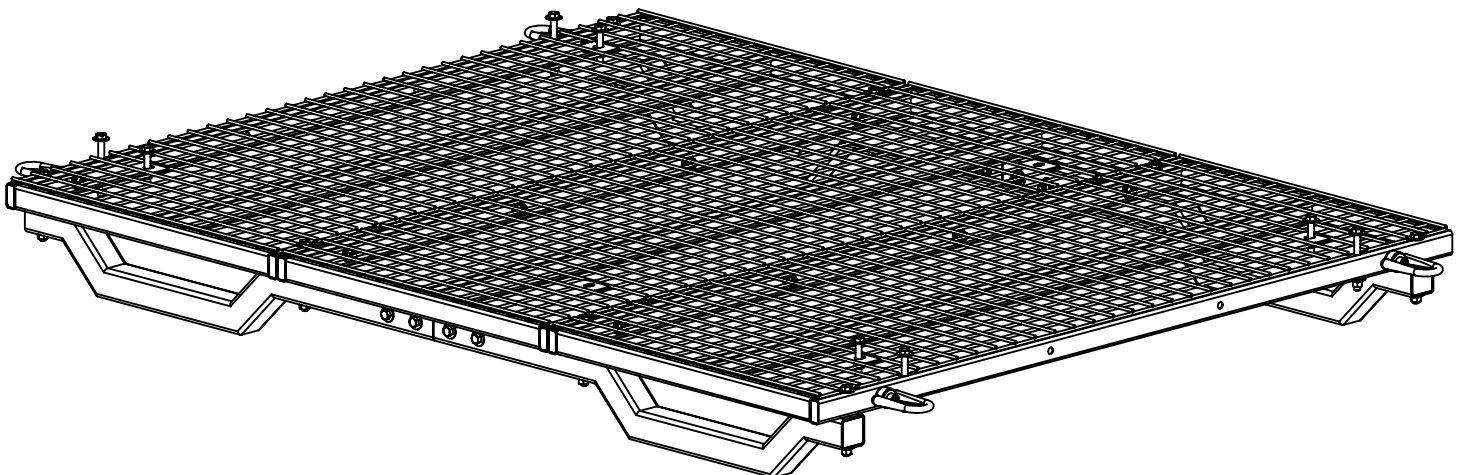

# -----BILL OF MATERIALS-----

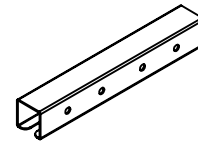
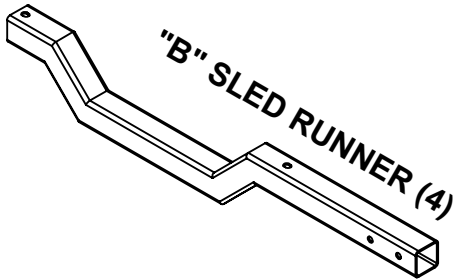
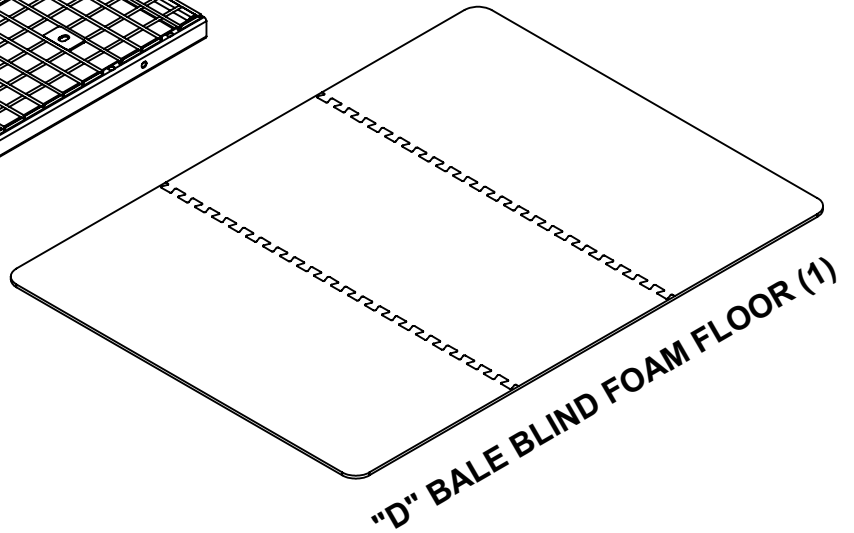
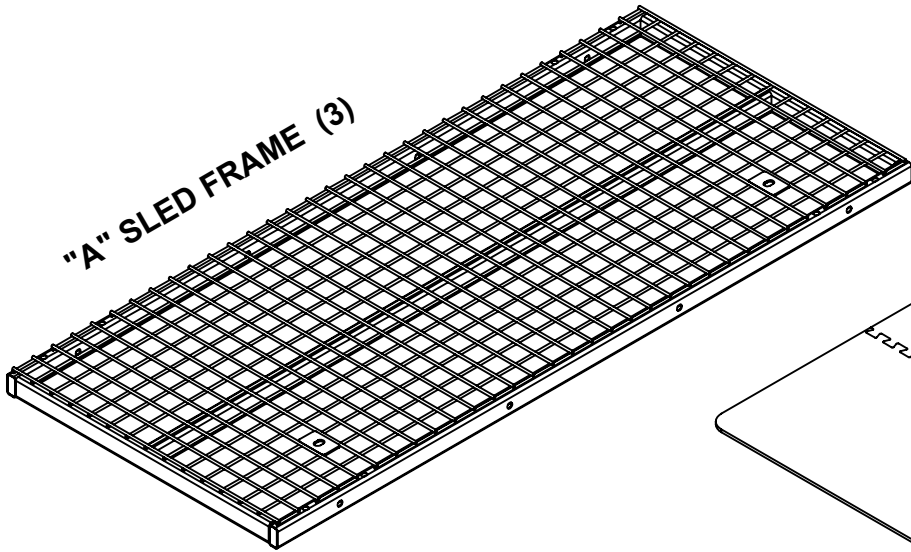

"C" SLED RUNNER CONNECTOR (2)

## HARDWARE

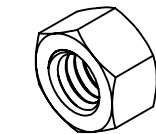
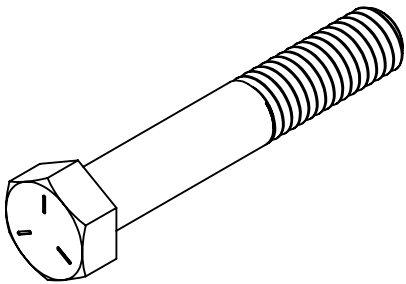

3/8 - 16 NUT  
(36)

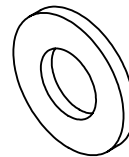

3/8 FLAT WASHER  
(72)

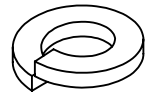

3/8 LOCK WASHER  
(36)

- 3/8 - 16 BOLT 2.25" LONG (12)
- 3/8 - 16 BOLT 2.75" LONG (8)
- 3/8 - 16 BOLT 3.75" LONG (4)
- 3/8 - 16 BOLT 4.25" LONG (8)

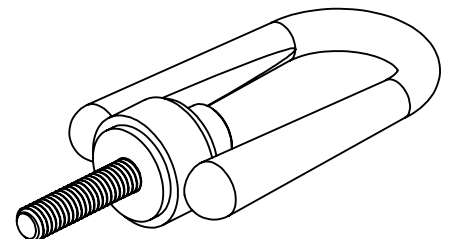

3/8 - 16 PULL RING  
(4)

### TOOLS REQUIRED (NOT INCLUDED)

- (2) 9/16 WRENCH FOR NUTS AND BOLTS  
(RATCHET AND SOCKET CAN BE USED ALSO)

\*THERE WILL BE LEFT OVER HARDWARE\*

**STEP 1:** Remove all parts from the packaging and familiarize yourself with them. Find the bill of material located on the second page of this manual and verify that all parts are present.

**STEP 2:** Place all 3 Sled Frame Part "A" on the ground face down as shown in Figure 10.1. All 3 of the frames are the same, make sure the metal tabs welded to the wire grid are towards the outside on both ends, see Figure 10.1. The tabs on the middle frame can face either direction, since nothing will be attaching to them. With the frames in place use the (8) sets of hardware, shown in Figure 10.2, to connect all of the frames together. Finger tighten each nut and bolt until you get all (8) in place, then fully tighten them all down. Make sure to not over tighten and crush the tube.

**Figure 10.3**

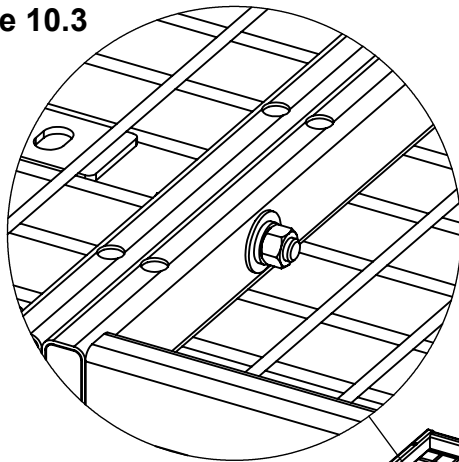

TABS

**Figure 10.1**

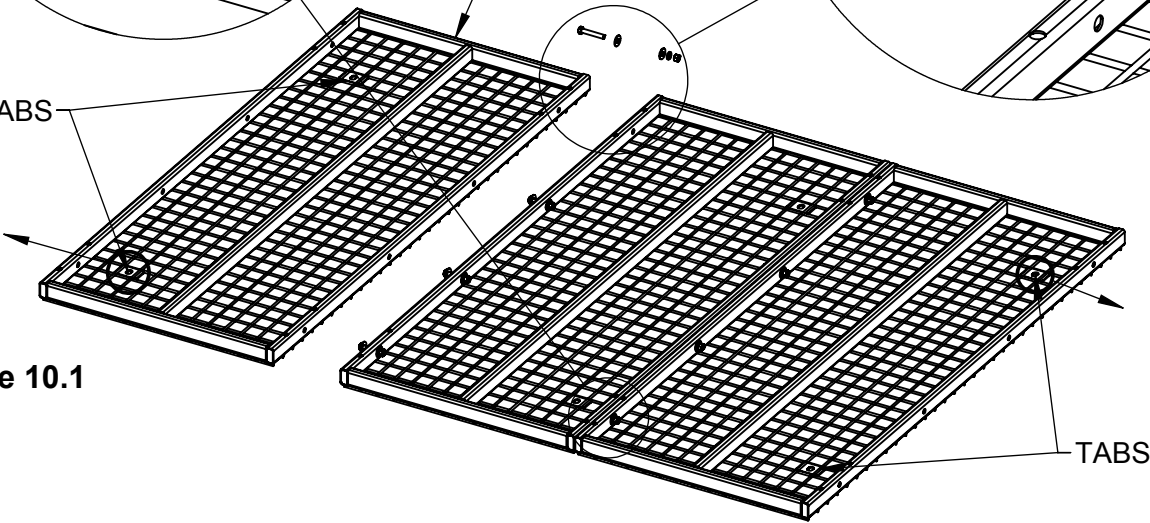

3/8-16 x 2.25" BOLT

"A"

3/8 FLAT WASHER

3/8 LOCK WASHER

3/8-16 NUT

**Figure 10.2**

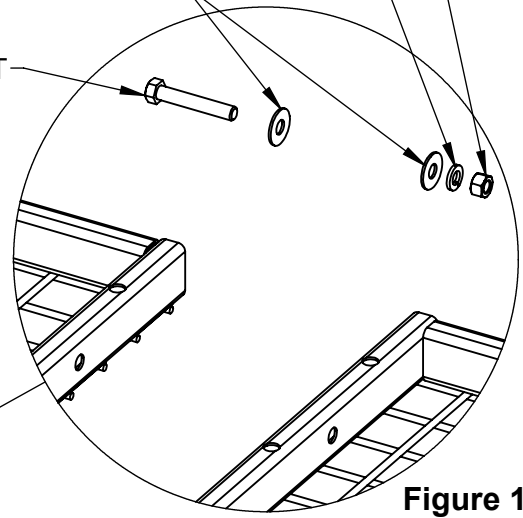

**STEP 3:** With all the frames connected together and still laying on its face, locate the Pull Rings. Insert the threads on the pull rings through the outer most holes on the frame, as shown in Figure 11.1 & 11.2. With the Pull Ring in place, secure it with the hardware on the back side of the tube, as shown in Figure 11.2. Make sure the Pull Rings are parallel with the frames so they will drop out of the way when they are not in use. Once they are in the correct position tighten the nuts into place, make sure to not over tighten.

**Figure 11.2**

3/8 FLAT WASHER

3/8 LOCK WASHER

PULL RINGS

3/8-16 NUT

PULL RINGS

**Figure 11.1**

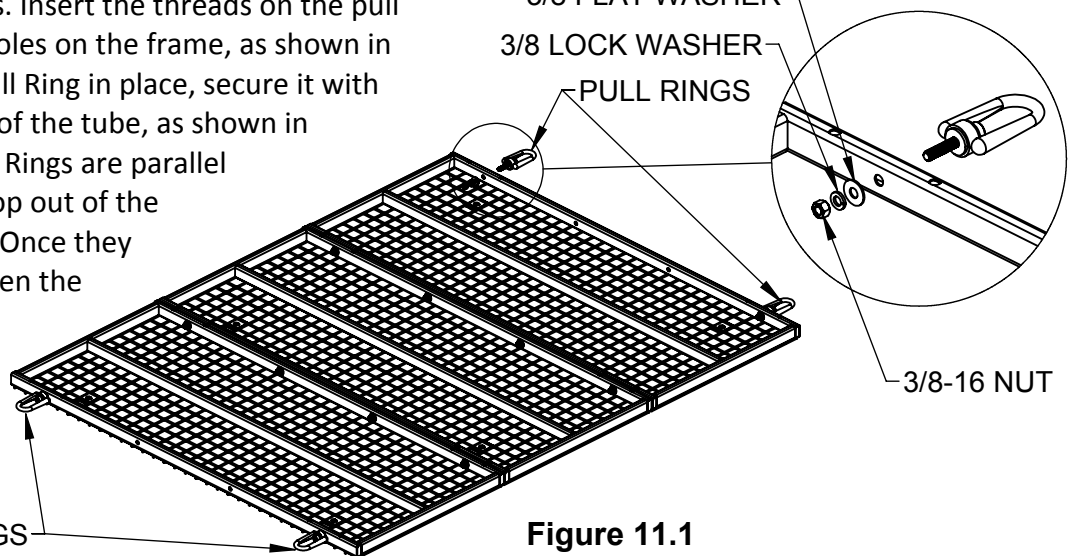

**STEP 4:** Place (1) Sled Runner Connector "C", inside (1) of the Sled Runner "B", as shown in Figure 12.1. Once inserted the Connector into the Sled Runner, use (2) sets of hardware to secure it into place, see Figure 12.2. Make sure to only tighten these nuts and bolts finger tight, so you can still have a little room to get the second Sled Runner onto the other side of the Connector. Once you get both Sled Runners on the Runner Connector, repeat these steps for the other Sled Runners and Runner Connector, make sure you do not tighten bolts until you assemble these Runners onto the Platform.

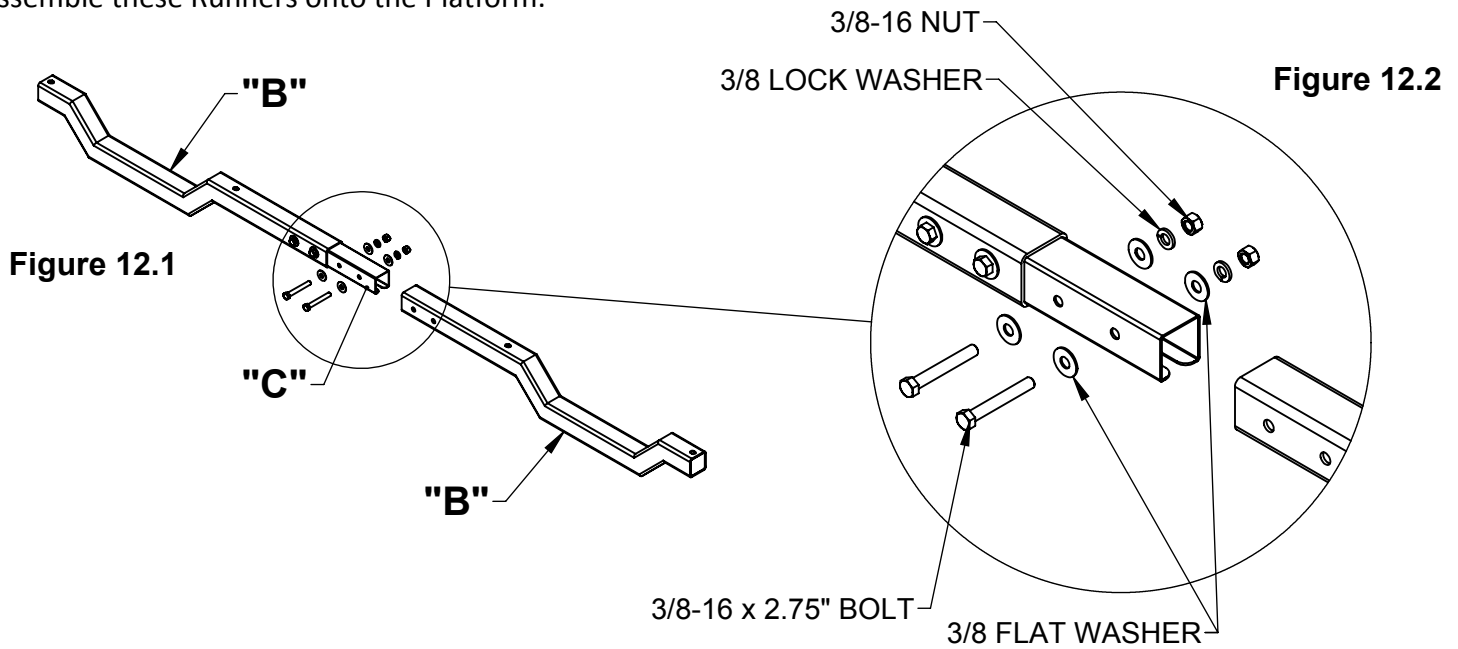

**STEP 5:** With the Top Platform & Sled Runners assembled, locate the (8) 3/8-16 x 4.25" and hardware, as shown in Figure 13.2. Align the hole in the end of the Sled Runner with the hole at the end of the Sled Platform, as shown in Figure 13.2. Make sure to insert the bolt from the top of the Platform down through the runner. Align the rest of the holes, and fasten them down, make sure to get them all finger tight until you get in all of the hardware on each Sled Runner. Repeat these steps for the other side Sled Runner. Once both the runners are connected, go back through and tighten all the bolts on the Runners and the ones that connect the Runner to the Platform. Make sure to not overtighten and smash the tubes.

**Figure 13.2**

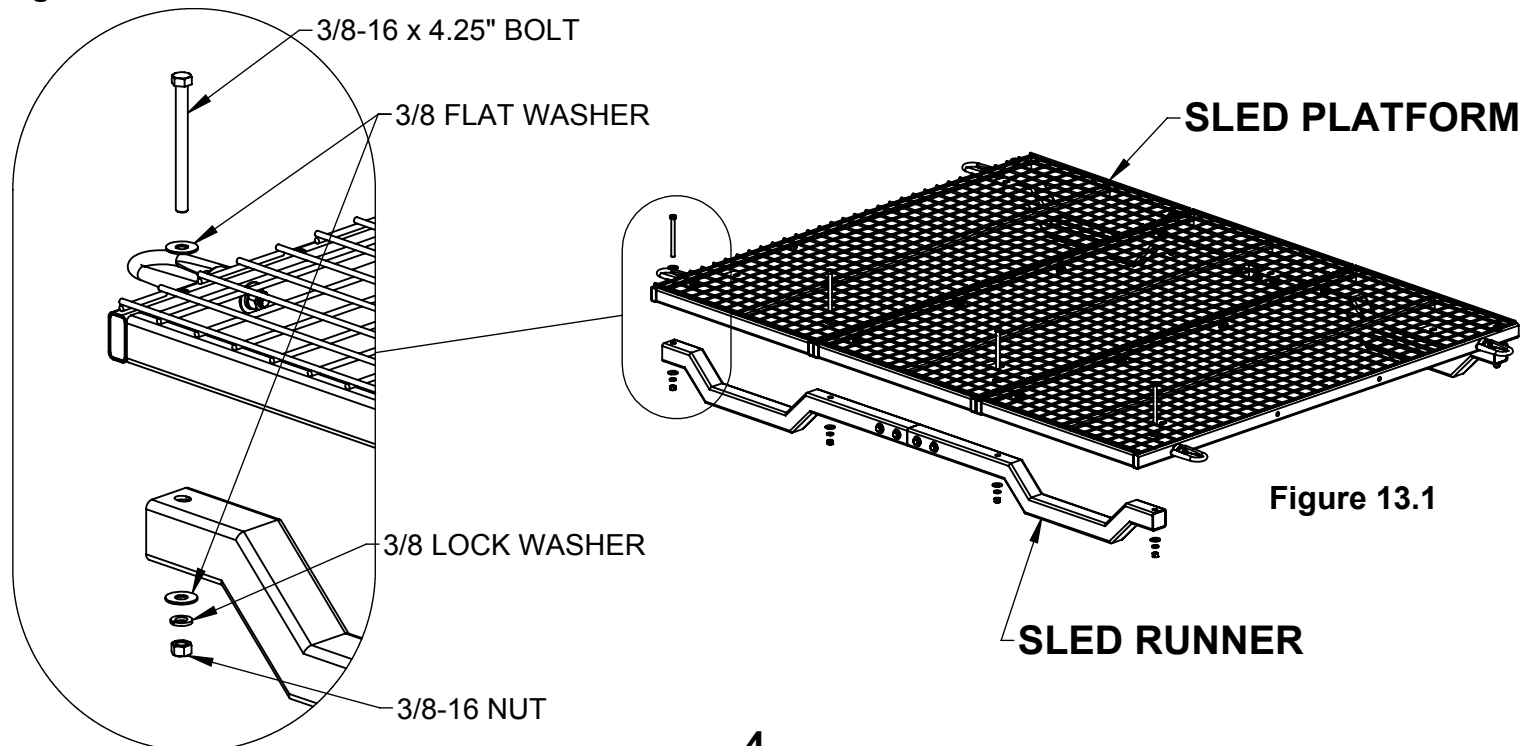

**STEP 6:** With the Sled complete it is time to set your Bale Blind frame on top of the Sled and secure it down. It will be easier to attach the End Frame Bottom Hoop "M", from your Sportsman or Outfitter blind, not included in this kit. See Figures 14.1 & 14.3, for tube locations on the Platform. When attaching the tubes to the frame for an Outfitter Blind you will connect it through the end holes on the Frame tubes, securing it with a 3.75" long bolt and hardware seen in Figure 14.2. Do this for both tubes, on both ends of the Sled Platform. Attaching tubes for a Sportsman Blind you will use the tabs with slots on the Platform grid. Attach the Sportsman tubes using 2.25" long bolts and hardware shown in Figure 14.2. Leave these tubes secured finger tight until the whole blind is assembled.

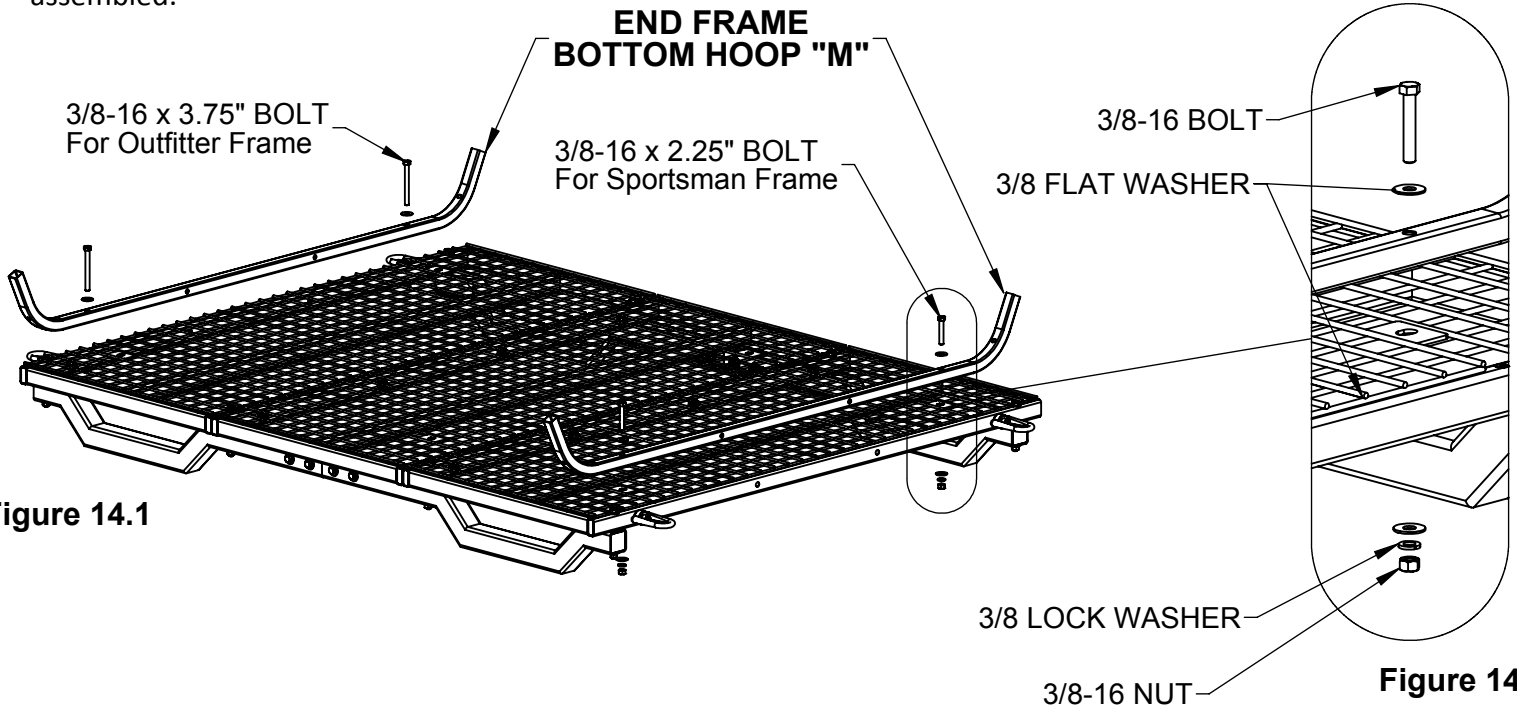

**Figure 14.1**

**Figure 14.2**

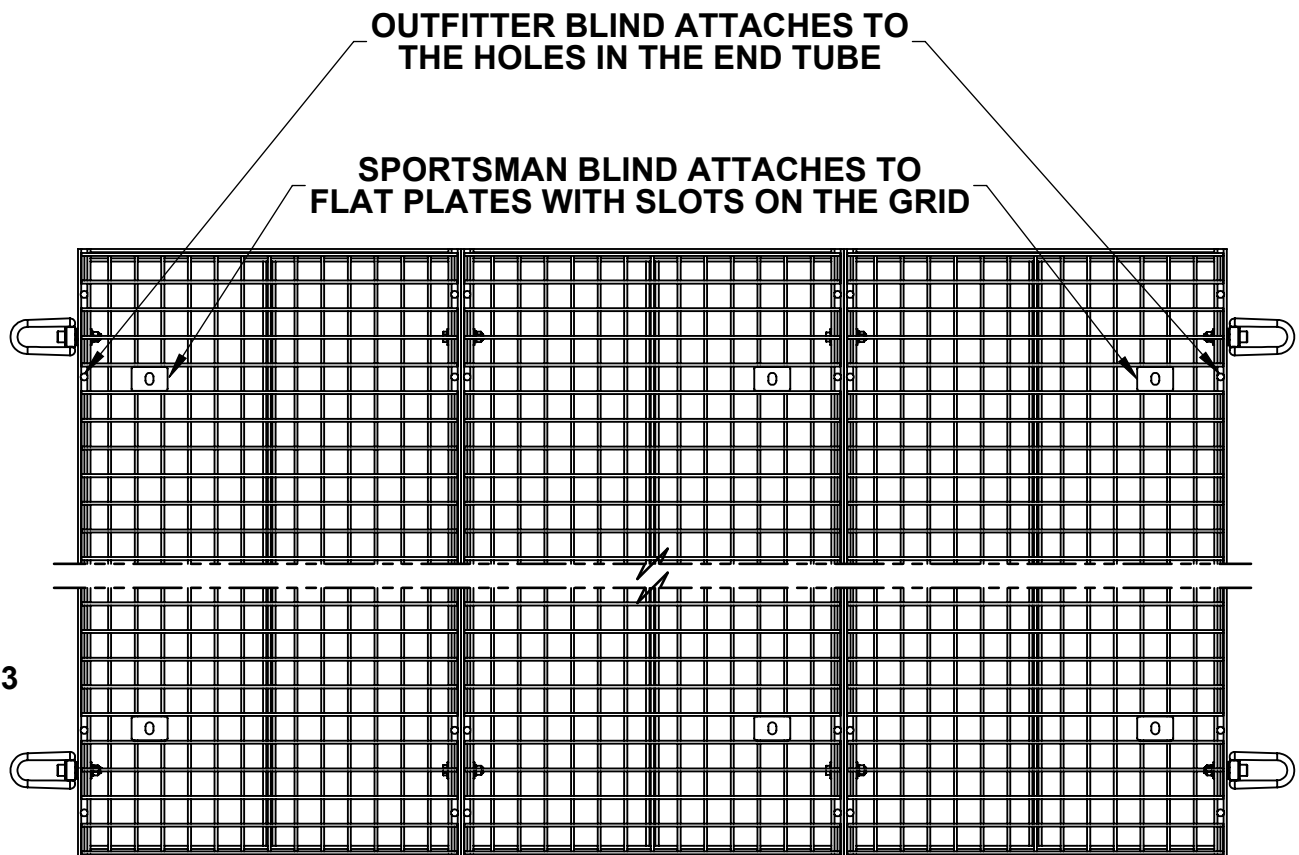

**Figure 14.3**

**STEP 7:** The Foam Floor for the Sled comes in (3) pieces as shown Below, Figure 15.1. One end of the Foam Floor has a perforated line, this is to make the Foam floor fit a Sportsman Blind or an Outfitter Blind. If you have an Outfitter Blind, no modification is needed, connect the floor as seen below and place into the floor of your blind. If you have a Sportsman Blind, you will need to cut along the perforated line, removing the excess at the end. This will ensure the foam floor will fit into your sportsman blind. You will only need to trim the one end of your foam floor. Once the floor is trimmed to size, connect it as seen below and insert it into your blind.

**Figure 15.1**

