

# BALANCE BALL®

## CHAIR SYSTEM

## Setup, Care & Safety Guide

Please read before setting up or using your Yoga for Kids Balance Ball® Chair System.

### TOOLS NEEDED

Balance Ball® pump (you may want to use a bicycle pump or compressor for initial inflation).

### SETUP

1. Remove the ball from packaging and inspect for shipping damage. It is normal for the ball to have slight creases or fold marks when first inflated.
2. Before inflating the ball, use the ruler to mark 38cm or 15" on wall or floor, or place two objects approximately 38cm apart. This will be your guide for proper inflation size.
3. Make sure that the ball is at room temperature before inflating.
4. Using the supplied pump, insert it into the inflation hole in the ball. Inflate the Balance Ball® to the desired height and firmness. DO NOT overinflate.
5. Remove pump from Balance Ball® and immediately insert plug into hole (so head is flush with surface of ball).
6. Never inflate the ball larger than 38cm or 15" in diameter.

### CARE

1. Clear workout area of sharp objects that may puncture the Balance Ball®. Use only on a smooth surface.
2. It is not necessary to deflate the Balance Ball® after use; however, slight leakage may occur over time. Re-inflate when necessary.
3. Hand wash the Balance Ball® Chair with a soft cloth and warm soapy water. Do not use harsh or abrasive chemicals or cleaning tools that may scratch or damage the Balance Ball® Chair.
4. Always check the Balance Ball® for nicks or scratches before each use. If damaged in any way, do not use.
5. Avoid placing or rolling the Balance Ball® on newspaper, photocopies or other materials printed in ink, as ink may permanently mark ball.
6. Avoid exposing the Balance Ball® to rough, sharp or abrasive surfaces, or to heat or excessive sunlight.
7. Do not store the ball against painted or wood surfaces for any prolonged period of time.

### RECOMMENDATION

- Recommended for children ages 5 - 8 ranging between 42" - 51".

### IMPORTANT SAFETY CAUTIONS!

1. Do not leave child unattended while using the Balance Ball Chair System.
2. Perform exercises in a slow and controlled manner.
3. Use the Balance Ball® Chair only on smooth surfaces. Do not use the Balance Ball® Chair if deep scratches or gouges exist.
4. Stop and rest if you feel dizzy or short of breath.
5. Please contact Gaiam for any product questions or regarding any defects. Manufacturer and distributor disclaim any liability, loss or damage caused by its use.
6. Do not lean against the back of the chair. This is not a back rest and is used to support exercises.

**CAUTION:** DO NOT place Balance Ball® in contact with woodwork, wood furniture or painted walls for any period of time. Damage to finish may occur.

### INFLATION NOTICE

- Inflate ball and plug.
- Ball may not inflate to 100% of size on initial inflation.
- Wait 24 hours.
- Deflate 50% and inflate again.
- Due to the ball's material, the ball will increase to proper size with second inflation.
- DO NOT OVERINFLATE. OVER INFLATION MAY CAUSE BALL TO EXPLODE.











# BALANCE BALL®

## CHAIR SYSTEM

### Setup, Care & Safety Guide

Please read before setting up or using your Yoga for Kids Balance Ball® Chair System.

#### PARTS INCLUDED

Letter	Part	Quantity
A		1
B		1
C		1
D		1
E		2
F		1
G		1
H		1
I		4
J		4
K		1

#### STEP 1

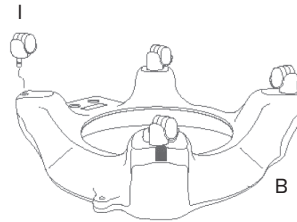

\*Insert the locking casters into the two rear legs. The two casters in the front legs should roll freely.

#### STEP 2

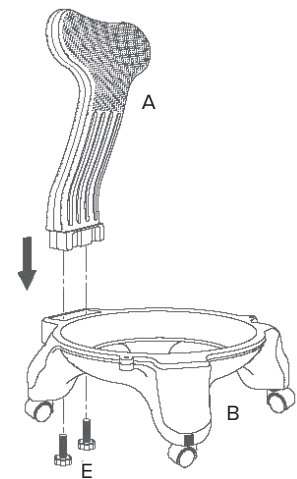

#### STEP 3

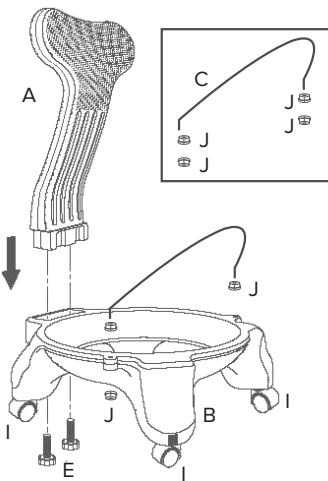

#### STEP 4

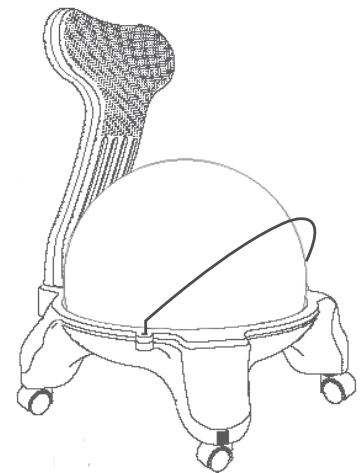
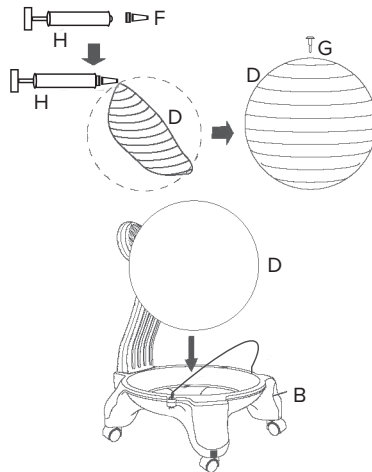

Learn more at <http://life.gaiam.com>