



# USER MANUAL

## IMPROVE TOWING SAFETY



10-Wheel Display  
for 3-Vehicle Memory



Real Time  
Tire Pressure &  
Temperature



Low Battery Power Alarm  
for Vehicle  
Trailer Battery.



Maximum  
Pressure  
Measured  
203psi



Active Alarm

---

---

## Tuson TPMS Retrofit Kit User Manual For TPMS4W & TPMS6W Models

---

---

### Contents

|     |   |    |
|-----|---|----|
| 1.  | Warning .....                           | 3  |
| 2.  | Product Parts List & Description.....   | 5  |
| 3.  | Product Specifications .....            | 10 |
| 4.  | TPMS Sensor Installation .....          | 12 |
| 5.  | TPMS Repeater Installation .....        | 19 |
| 6.  | TPMS Receiver Installation .....        | 23 |
| 7.  | Driving Mode Menu .....                 | 27 |
| 8.  | Settings Mode Menu: .....               | 39 |
| 9.  | Alarm Warning and Display Symbols ..... | 59 |
| 10. | Troubleshooting.....                    | 62 |
| 11. | Customer Service .....                  | 64 |
| 12. | Notes .....                             | 65 |
| 13. | Limited Warranty .....                  | 68 |

## 1. Warning

### 1.1 Federal Communication Commission Interference Statement:

This equipment has been tested and found to comply with the limits for a Class B digital device, pursuant to Part 15 of the FCC Rules. These limits are designed to provide reasonable protection against harmful interference in a residential installation. This equipment generates, uses and can radiate radio frequency energy and, if not installed and used in accordance with the instructions, may cause harmful interference to radio communications. However, there is no guarantee that interference will not occur. If this equipment does cause harmful interference to radio or television reception, which can be determined by turning the equipment off and on, the user is encouraged to try to correct the interference by one of the following measures:

- Reorient or relocate the receiving antenna.
- Increase the separation between the equipment and receiver.
- Connect the equipment into an outlet on a circuit different from that to which the receiver is connected.
- Consult the dealer or an experienced radio/TV technician for help.

FCC Caution: Any changes or modifications not expressly approved by the party responsible for compliance could void the user's authority to operate this equipment.

This device complies with Part 15 of the FCC Rules. Operation is subject to the following two conditions: (1) This device may not cause harmful interference, and (2) this device must accept any interference received, including interference that may cause undesired operation.

---

## **1.2 Product Warning:**

- 1.2.1** Do not adjust the TPMS receiver while driving. The company is exempt from all consequences because of driver's careless and improper operation.
- 1.2.2** The system uses wireless RF transmission signals. In some special circumstances, interference or erroneous methods of operation or installation may cause weaker signal or its inability to receive signals. If the insulation adhesive sticker of the windshield contains metal material, it may affect signal reception. If the tire pressure and temperature readings on the TPMS receiver are displayed as "---", this indicates that the receiver is not receiving the signals emitted by the sensors. Drive the vehicle away from the current location (where there may be some signal interference) or drive the vehicle to a tire shop to check.
- 1.2.3** If the battery status of the TPMS sensors inside the tire is low, "---" will be shown on the receiver display (if abnormal conditions continue to occur, the TPMS sensors will continuously emit signals to warn the driver, resulting in shorter sensor battery life). Please go as soon as possible to a service station to confirm whether the TPMS Sensors need to be replaced.
- 1.2.4** Temporary resealing or re-inflation products containing internal sealants or propellants in any tire assembly may adversely affect the operation of the sensor/transmitter. The product manufacturer does not assume any liability as to the customer's use of internal sealants or propellants with the tire sensors used with this TPMS.
- 1.2.5** Do not leave the sensors in contact with chemicals, it may cause the sensors to fail.

**1.2.6** The TPMS needs to be installed by qualified technicians in accordance with the installation manual for the TPMS warranty to be valid. If the TPMS sensor is improperly installed or disassembled causing damage to the sensors, the warranty will not cover this type of damage.

## 2. Product Parts List & Description

| Part No.                                     | TPMS4W | TPMS6W |
|--|--------|--------|
| Sensor                                       | 4      | 6      |
| Interchangeable Valve Stem (0.625" / 0.453") | 4      | 6      |
| TPMS Receiver (Monitor)                      | 1      | 1      |
| Repeater                                     | 1      | 1      |

### Accessories in the box:

- Cigarette Lighter Cable (Vin=12~24V) x 1
- Suction Cup Holder x 1
- Wheel Orientation Mark Sticker Sheet x 1
- Cable Tie x 5
- User Manual x 1
- Registration Card x 1

## 2.2 Sensor Description

The Tuson TPMS Retrofit Kit sensors are automotive-grade sensors designed to monitor tire pressure and temperature consistently and wirelessly transmit data to the receiver. Each sensor has a unique ID# to identify the sensor to the receiver. These are internal sensors that are securely mounted to the valve stem or using a band and bracket kit (not included) inside the tire to prevent damage and/or theft. Internal sensors provide more accurate pressure and temperature readings than external sensors. The sensors are motion-activated and will go into sleep mode when the wheels stop moving to preserve sensor battery life. Sensors may take a few minutes to wake-up. Once the wheel speed is over 12 mph/20 kph, then the sensor will wake-up and will continue transmitting messages to the receiver every minute while moving. As a general reference, the sensor battery life is about 5 years when driven 4 hours per day. **See section “4. TPMS Sensors Installation” on how to install the sensors.**

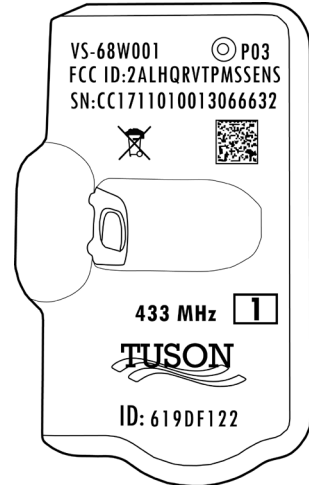

## 2.3 Interchangeable Valve Stem (IVS) Description

The Tuson TPMS' tire sensors use a metal interchangeable valve stem (IVS) that is designed to fit through either 0.453" or 0.625" diameter wheel valve holes for your convenience. The IVS is compatible with both steel and aluminum wheels. The valve stem and nut portion of the IVS are made of anodized aluminum and the washer is made of nickel-plated steel. A polybag containing the IVS comes pre-assembled with the 0.625" diameter rubber grommet; metal washer; 0.625" diameter nut and valve cap on the valve stem. A 0.453" diameter rubber grommet and nut are also included in the polybag for each IVS. The IVS should be installed in the wheel using a single rubber grommet only. **WARNING!** – Do not use both sizes of the included grommets to install the valve stem. **See Section "4. TPMS Sensors Installation" on how to install the sensors.**

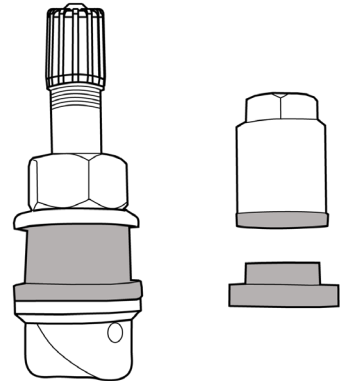

## 2.4 Repeater Description

The Tuson TPMS Retrofit Kit includes a repeater. The repeater features power (red) with 2 amp fuse and ground (black) wires to connect to the trailer battery or any power source that provides a constant 12/24V power. The repeater is designed to boost the signal strength from the tire sensors to the receiver (monitor) in the tow vehicle. The repeater is waterproof and can be exposed to the outside elements without being damaged. On trailers greater than 20 feet long, the repeater must be installed to provide the receiver enough signal strength from the sensors. For small trailers, the receiver may pick up the sensors without the repeater installed however, we highly recommend you install the repeater. In addition to boosting signal strength, the repeater is also designed to transmit the trailer battery voltage to the receiver. The repeater does not need to be disconnected from the power source, because it is motion activated and will go into sleep mode when the trailer is not moving. Therefore, the repeater may take a few minutes while driving to wake-up and start transmitting messages to the receiver. **See section “5. TPMS Repeater Installation” on how to install the repeater.**

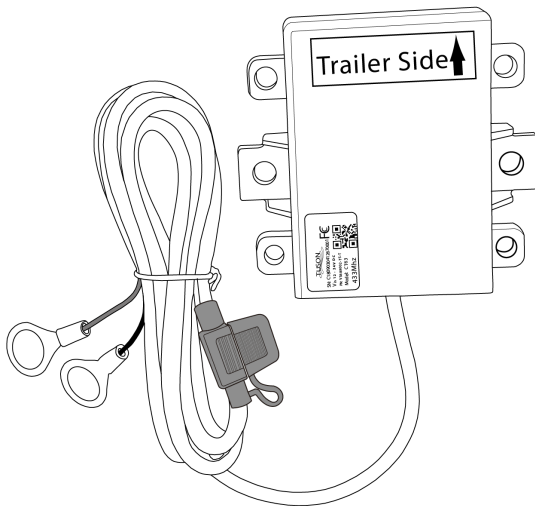



## 2.5 Receiver Description

The receiver (monitor) allows the driver to monitor the tire pressure and temperature of up to 10-wheels for up to 3-vehicle memory selections. The receiver will also monitor trailer battery voltage when the repeater is connected to a trailer battery. A 12~24V cigarette lighter cable is included to power the receiver in the tow vehicle. The **Tuson Display Power Cable** (sold separately) can also be used to power the receiver with a 9V battery to make the “Tire Sensor ID Pairing” in section 8.5 easier. The receiver has two menus: Driving Mode and Setting Mode. When in Driving Mode, the receiver will automatically cycle between pressure, temperature, and trailer battery for that selected vehicle memory. When in Settings Mode, you can select the vehicle memory to customize and monitor when in Driving Mode. When monitoring more than 6-wheels on a vehicle memory, the Driving Mode will display the pressure and then temperature for the first 6-wheels and then the pressure and temperature for the additional wheels in the next screen before moving to the trailer battery voltage screen. Alerts on the receiver will continue to appear until the issue with the sensor or repeater has been addressed/cleared. **See section “6. TPMS Receiver Installation” on how to install the receiver and button functions.**



### 3. Product Specifications

#### Vehicle Types for TPMS use (Maximum 10-wheels):

Tuson TPMS is designed for all types of RV, commercial and livestock trailers. Great for commercial and passenger vehicles as well!

#### 3.1 Sensor Specifications

| ITEM                              | SPECIFICATION   |
|-----------------------------------|---|
| Operating Voltage                 | 3V DC  |
| Operating Frequency               | 433 MHz   |
| Operating Temperature             | -22°F~257°F (-30°C~125°C)   |
| Storage Temperature               | -40°F~257°F (-40°C~125°C)   |
| Tire Pressure Monitoring Range    | 0~203 ±1.5 psi (0~1400 ±10 kPa)   |
| Tire Temperature Monitoring Range | -40°F~257°F±5.4°F (-40°C~125°C±3°C)   |
| Weight                            | 30 g (1 Oz)   |

#### 3.2 Repeater Specifications

| ITEM                  | SPECIFICATION   |
|-----------------------|---|
| Operating Voltage     | 12~24V DC  |
| Operating Current     | 11.2 mA   |
| Operating Frequency   | 433 MHz   |
| Operating Temperature | -4°F~185°F (-20°C~85°C)   |

|                     |                                  |
|---------------------|----------------------------------|
| Storage Temperature | -40°F~185°F (-40°C~85°C)         |
| Cable Length        | 90 inches (2300 mm)              |
| Size                | 3.5"x3.8"x0.9" (88 x 96 x 23 mm) |
| Weight              | 6 Oz (170 g)                     |

### 3.3 Receiver Specifications

| ITEM                        | SPECIFICATION   |
|-----------------------------|---|
| Operating Voltage           | 12~24V DC  |
| Operating Current           | 120 mA  |
| Operating Frequency         | 433 MHz   |
| Operating Temperature       | -4°F~185°F (-20°C~85°C)   |
| Storage Temperature         | -40°F~185°F (-40°C~85°C)  |
| Monitored Pressure Range    | 0~203 ±1.5 psi (0~1400 ±10 kPa)   |
| Monitored Temperature Range | -40°F~257°F ±5.4°F (-40°C~125°C ±3°C)   |
| Size                        | 4.5"x2.1"x1" (116.5 x 53 x 25 mm)   |
| Weight                      | 3.4 Oz (95 g)   |

Note: When using kPa as the unit of air pressure, the monitor will display "Hi" if the air pressure is over 999kPa. The actual air pressure values will be displayed numerically when the unit of measure selected is in psi or Bar.

## 4. TPMS Sensor Installation

### <IMPORTANT 1>

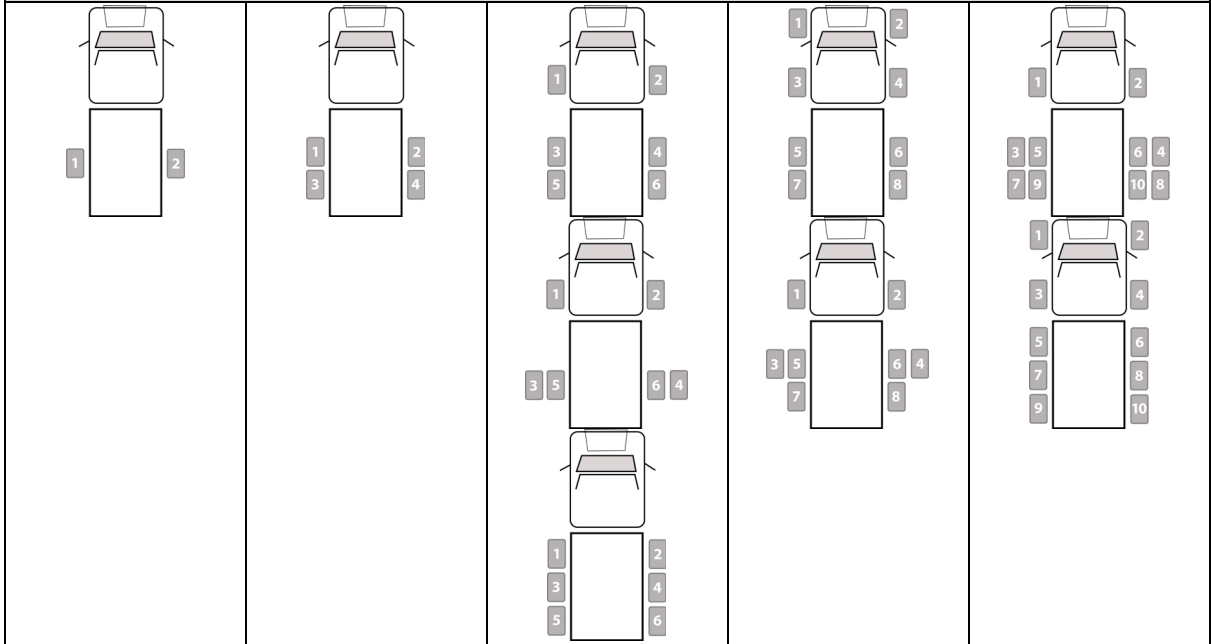

Figure 4.1 Wheel Orientation Mark

Each sensor has a unique Sensor ID# to identify the sensor to the receiver. The sensors included in the kit are already paired to the receiver from the factory for ease of installation and have a designated wheel orientation mark (1, 2, ... 6) on the sensor (see **Figure 4.1**). The wheel orientation mark on each kit sensor corresponds to a tire location on the vehicle and/or trailer. It is important to install the kit sensors to the corresponding wheels on the vehicle and/or trailer (see **Table 4.1 for reference**). If the sensors are installed in the correct corresponding wheel locations in Table 4.1 for up to six (6) sensors, then you can skip **Setting “8.5 Tire Sensor ID Pairing to the Receiver”** from **Section “8. Settings Mode Menu”** (**Note:** If installing additional sensors not included in the kit, the “8.5 Tire Sensor ID Pairing to Receiver” must be performed for the additional sensors only.)

Table 4.1 Sensor Wheel Orientation Mark Numbers and Vehicle Tire Location for CAR 1\*

**Vehicle Tire Location**



**Sensor Wheel Orientation Mark Numbers for CAR 1\***

1-2

1-4

1-6

1-8

1-10

**For Other Custom Vehicle Configurations, please see note below:**

Note: For initial installation, the sensor orientation mark should be installed in the following order:

1. Sensors on the LEFT side are ODD numbered
2. Sensors on the RIGHT side are EVEN numbered
3. Each vehicle side will have sensors increase in odd or even consecutive order from front to back
4. For vehicles with dually axles, the outside tires should have the lower numbered marking and the inside tires should have the higher numbered marking.

\*Wheel orientation marks used per vehicle selection: CAR 1 ~ 1-10, CAR 2 ~ 11-20, CAR 3 ~ 21-30

**<IMPORTANT 2>**

The sensors' ID# and wheel orientation mark included in the kit are listed in **Section "12.3 Sensor ID#s List for Each Vehicle Memory Selection"** of each user manual. BEFORE installing additional sensors not included in the kit, it is highly recommended that the sensor ID#s be recorded in Section 12.3 next to the corresponding wheel orientation mark for easy identification when pairing.

**The Interchangeable Valve Stem (IVS) Service Kit**

The Tucson TPMS tire sensors use a metal interchangeable valve stem (IVS) that fits through 0.453" and 0.625" diameter wheel valve holes. (**Note:** If neither grommet size fits the wheel valve hole, a TPMS steel band and cradle kit can be purchased separately without replacing the existing valve stem.)

Please **circle** the grommet size that was used for your tire application for easy identification and replacement: 0.453" or 0.625".

### <IMPORTANT 3>

Each IVS service kit comes with two (2) rubber grommet sizes: one (1) fits 0.453" diameter wheel valve holes and one (1) fits 0.625" diameter wheel valve holes. The IVS should be installed using a single grommet only. **WARNING!** – Do NOT use both sizes of the included rubber grommets to install a single valve stem. Please check and make sure that the correct grommet size is used for the valve stem and fits the wheel's valve hole diameter prior to TPMS sensor installation.

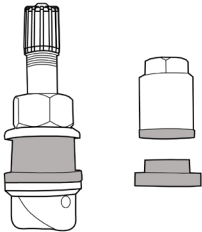

The IVS service kit comes pre-assembled with the 0.625" diameter rubber grommet; metal washer; 0.625" diameter nut and valve cap on the valve stem and includes a separate 0.453" diameter grommet and nut in the polybag.

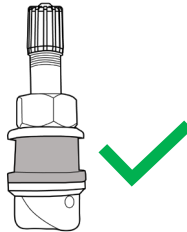

Please use the pre-assembled 0.625" diameter grommet on the valve stem if the wheel valve hole is 0.625" diameter.



When the valve hole of the wheel is 0.453" diameter, disassemble the pre-assembled IVS valve stem. Remove the 0.625" diameter rubber grommet, metal washer, nut from the valve stem. Assemble the 0.453" diameter grommet, nut and cap in order.

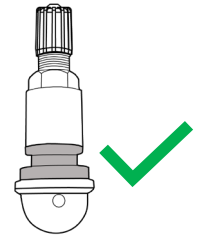

## 4.1 TPMS Sensor Installation:

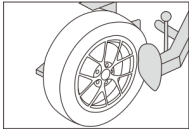

(Fig 1)

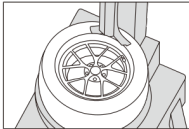

(Fig 2)

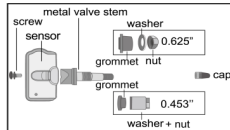

(Fig 3)

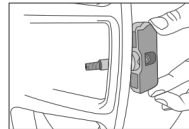

(Fig 4)

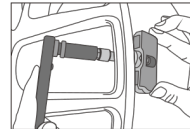

(Fig 5)

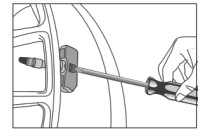

(Fig 6)

(Fig 1) & (Fig 2) Deflate and remove the tire from the wheel using a tire mounting machine.

(Fig 3) Assemble the sensor to the metal valve stem using the mounting screw (make sure to use the correct grommet size is on the metal valve stem), then remove the cap, 0.625" washer and nut (OR 0.453" nut) from the metal valve stem.

(Fig 4) Insert the metal valve stem through the wheel's valve hole, making sure to properly seat the rubber grommet in the valve hole. Then place the back of the sensor body to face the inner surface of the rim, so that the sensor is parallel to the rim.

(Fig 5) Holding the sensor in place, guide the washer (for 0.625" ONLY) onto the metal valve stem on the outside of the valve hole. Then secure the 0.625" OR 0.453" nut on the metal valve stem and torque to 2.95 Ft-lbs (4 N-m). Once secured, affix the cap to the metal valve stem.

(Fig 6) Secure the sensor to the metal valve stem and torque the screw to 1.48 Ft-lbs (2N-m).



Now remount the tire back onto the wheel, being careful not to damage the tire pressure sensor during mounting of the tire. Each TPMS retrofit kit comes with a wheel orientation mark sticker sheet to easily identify wheel location on the receiver display and for which vehicle selection.

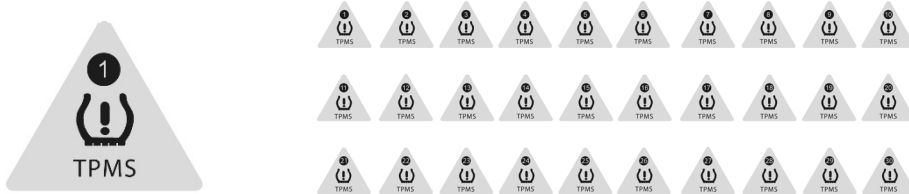

To apply the sticker to the wheel, clean the surface of the wheel near the valve stem with isopropyl alcohol and allow to dry completely. Do not use brake cleaner or other harsh chemical solvents to prepare the wheel surface for sticker application. Make sure the wheel surface is clean and dry then adhere the corresponding wheel ID sticker to the clean surface near the valve stem. This will help remind technicians to install the wheel back to the correct location according to your defined wheel position.

Lastly, balance the wheel as you would normally, adding weights if necessary, to achieve rotational balance.

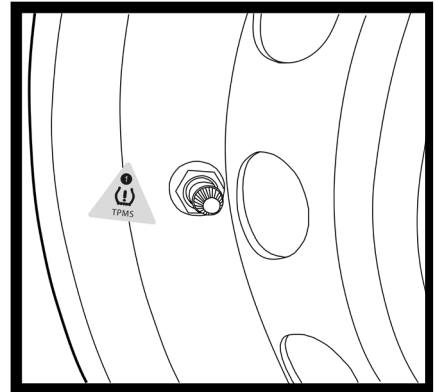

#### <IMPORTANT 4>

When removing the tire from the wheel rim to install our Tuson TPMS Retrofit Kit, be aware that if the valve stem is secured by a nut, there might be a sensor already installed, be careful not to damage the sensor during the tire removal process.

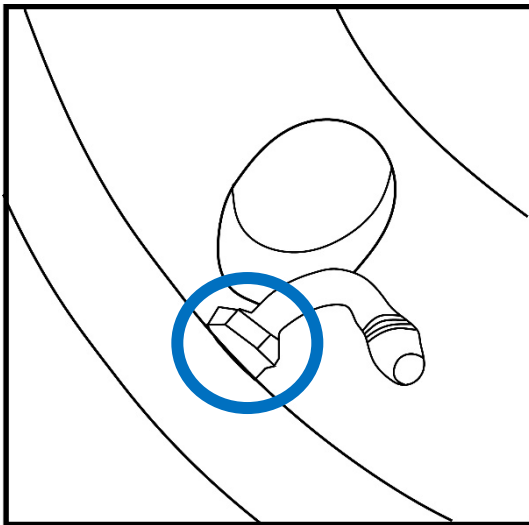

## 5. TPMS Repeater Installation

### 5.1 Repeater Image

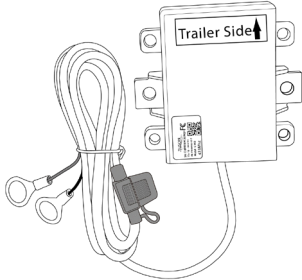

### 5.2 Installation Steps

The repeater is designed to boost the sensors' RF signals to the receiver in the tow vehicle. The mounting location of the repeater will depend on the type of trailer (bumper pull trailer, 5<sup>th</sup> wheel or gooseneck trailer) the TPMS will be installed on. Select a horizontal surface location to mount the repeater on the front section of the trailer, keeping in mind that the cable ends of the power cord will need to connect to the trailer battery. For optimal signal performance, the key is to have the least obstructed transmission path between the sensors, repeater and receiver. Ideally, to get the best RF transmission between repeater and tire pressure sensors, the repeater should be in an open space with no barriers between the tire pressure sensors and the receiver. Do NOT install the repeater in an enclosed metal space that will block the RF signals.

The repeater is waterproof and can be exposed to the outside elements without being damaged. To review the repeater specification, please refer to the **Section 3.2**.

<IMPORTANT 5>

When mounting the repeater, the power cord side of the repeater must be facing the tow vehicle and the arrow on the “Trailer Side ↑” sticker must be pointing toward the trailer wheels in order to work properly as shown in **FIGURE 5.2**

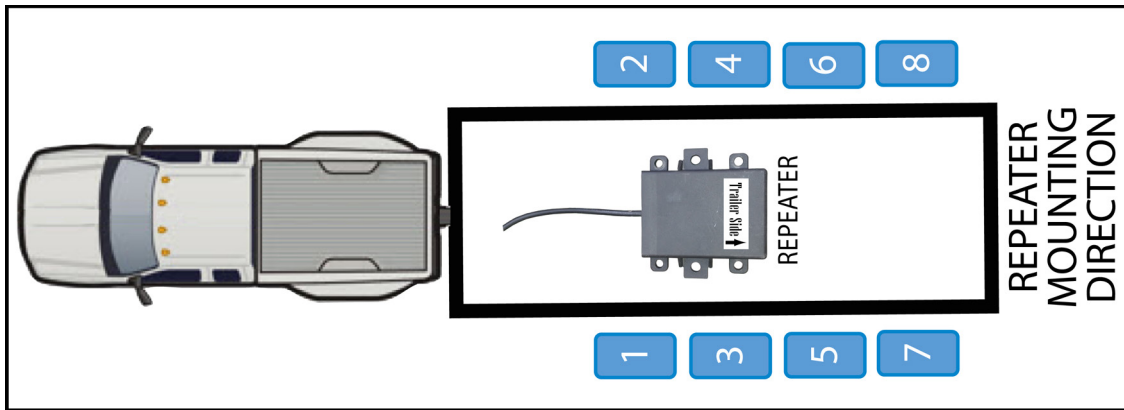
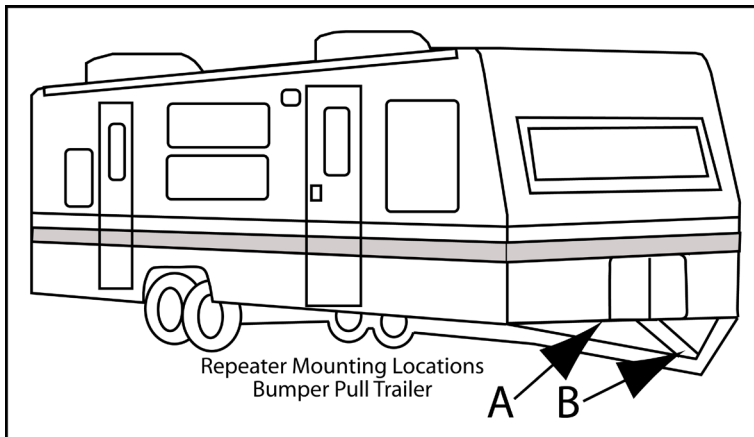

Figure 5.2 Repeater Mounting Direction

**5.2.1 For travel, cargo or equipment trailers with a bumper pull A-frame hitch, see Figure 5.2.1** locations “A” and “B” for recommend repeater mounting locations. Location “A” is on an exposed

frame member on the underside of the trailer and location “B” is on the A-frame of the bumper pull trailer.



*Figure 5.2.1 Repeater Mounting Locations Bumper Pull Trailer*

- 5.2.2 For 5<sup>th</sup> Wheels and gooseneck trailers** select a location for the repeater near the house battery but NOT inside a metal enclosure. See **Figure 5.2.2** locations “A” and “B” for recommend repeater mounting locations. Location “A” is on an exposed frame member on the underside of the trailer and location “B” is inside the storage compartment of your fifth wheel or gooseneck trailer.

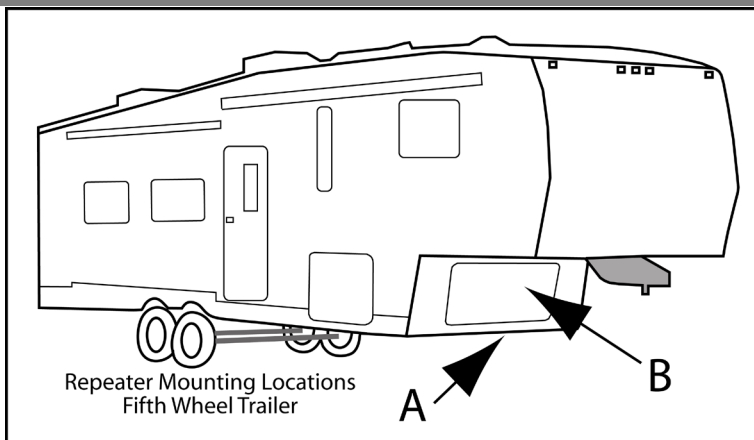

Figure 5.2.2 Repeater Mounting Locations Fifth Wheel Trailer

- 5.2.3** The repeater comes with a peel off adhesive foam pad and self-tapping screws that go through the mounting holes on the edge of the housing to securely mount the repeater. Before permanently mounting the repeater with the screws, temporarily mount the repeater to the desired location and confirm that the sensor(s) and trailer battery data is being received and displayed by the receiver. The sensors are activated by either driving for a short distance or adding/removing air pressure from the tires. Once the readings appear for all of the installed sensors and the trailer battery voltage is showing, the repeater mounting location has been confirmed. Make sure the repeater is mounted in the correct orientation, use the adhesive foam pad and/or the self-tapping screws to

secure the repeater. If using the foam adhesive pad to mount the repeater on a trailer frame member, we recommend using at least two screws to fasten the repeater to act as a backup in case the adhesive loses its grip over time.

- 5.2.4 After securely mounting the repeater to the trailer, route the power wires to the trailer battery. Mount the O-ring connectors on the repeater's power wires to the proper trailer battery terminals. Connect the RED O-ring terminal to the POSITIVE (+) battery terminal and the BLACK (-) O-ring terminal to the NEGATIVE (-) battery terminal.
- 5.2.5 Use the cable ties to avoid a loose repeater power cable by fastening the repeater power cable to the frame of the trailer or 5<sup>th</sup> wheel. Avoid overtightening cable ties to prevent cutting into the cable.

## 6. TPMS Receiver Installation

### 6.1 Receiver Image



## 6.2 TPMS Receiver Installation

(Fig 1) Clean the windshield where the receiver will be adhered to and allow to dry. Attach the TPMS receiver to the suction cup holder and adjust the receiver to the proper angle. Press the suction cup holder against the desired location on the windshield. Make sure that the antenna is not bent or damaged during the installation.

(Fig 2) Insert the power cable into the bottom of the receiver.

(Fig 3) Insert the cigarette lighter side of the power cable into the cigarette lighter socket to supply power to the receiver.

(Fig 4) Press the red "PUSH ON" button on the cigarette lighter power cable to power the Receiver.

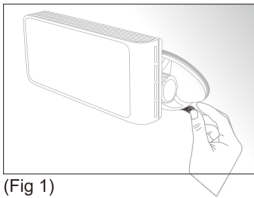

(Fig 1)

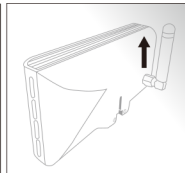

(Fig 2)

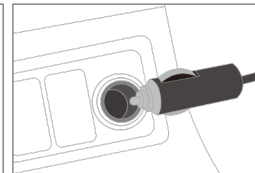

(Fig 3)

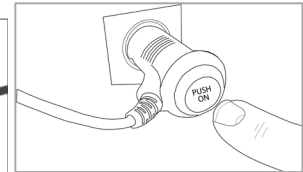





(Fig 4)

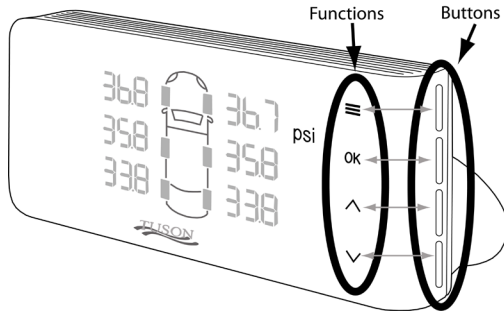



### 6.3 TPMS Receiver Display Button Functions



There are four buttons, from top to bottom, on the right side of the receiver. Once the receiver is powered on, the display button functions     will appear on the right side of the display and corresponds with each of the four buttons on the right side of the receiver. The next page is a list of the button functions.

| Display Button Icon   | Button Functions  |
|---|---|
| <br>MENU | <ul style="list-style-type: none"> <li>• <b>Review paired sensor ID#s to each vehicle selection &amp; wheel location –</b> Hold down and add power to the receiver</li> <li>• <b>Switch between Mode Menus –</b> Hold for 3 seconds</li> </ul> <p><b><u>Driving Mode Menu</u></b></p> <ul style="list-style-type: none"> <li>• <b>View one parameter only (pressure/temperature/trailer battery) –</b> Press</li> <li>• <b>Return to view all parameter values of a vehicle selection on rotational display mode –</b> Press again</li> </ul> |

|   |   |
|---|---|
|  <p>SELECT</p>     | <p><b><u>Driving Mode Menu</u></b></p> <ul style="list-style-type: none"> <li>• <b>Mute Alarm</b> – Press when alarm sounds (Alarm will sound again if receiver power is reset and issue is not addressed, or another alarm occurs in the same wheel or in other wheels)</li> <li>• <b>Turn OFF Screen</b> – Hold for 3 seconds (receiver is working in the background and will turn on if alarm occurs. Press any button to turn ON screen)</li> </ul> <p><b><u>Setting Mode Menu</u></b></p> <ul style="list-style-type: none"> <li>• <b>Select Setting to View/Modify</b> – Press to view/modify the specific setting and the parameter/value will start blinking</li> <li>• <b>Program Setting Selection/Values</b> – Press for each blinking selection or value you would like to program (a short beep will sound if program is saved)</li> </ul> |
|  <p>UP ARROW</p>   | <p><b><u>Driving Mode Menu</u></b></p> <ul style="list-style-type: none"> <li>• <b>Increase Alarm Volume</b> – Press</li> </ul> <p><b><u>Setting Mode Menu</u></b></p> <ul style="list-style-type: none"> <li>• <b>Navigate Setting Screens</b> – Press to scroll through different setting screens</li> <li>• <b>Modify Setting Selection/Values</b> – Press when selection/value is blinking</li> <li>• <b>Rapid Increase in Value</b> – Press and hold to quickly reach the desired pressure or temperature value</li> </ul>   |
|  <p>DOWN ARROW</p> | <p><b><u>Driving Mode Menu</u></b></p> <ul style="list-style-type: none"> <li>• <b>Decrease Alarm Volume</b> – Press</li> </ul> <p><b><u>Setting Mode Menu</u></b></p> <ul style="list-style-type: none"> <li>• <b>Navigate Setting Screens</b> – Press to scroll through the different setting screens</li> <li>• <b>Modify Setting Selection/Values</b> – Press when selection/value is blinking</li> <li>• <b>Rapid Decrease in Value</b> – Press and hold to quickly reach the desired pressure or temperature value</li> </ul>   |

## 7. Driving Mode Menu

Once all TPMS hardware installation is complete and the receiver is turned on, the receiver will automatically display in Driving Mode for the default vehicle selection: CAR 1. The Driving Mode cycles between tire pressure, tire temperature and vehicle/trailer battery voltage display screens in a rotating sequence and will show green dash lines “- -” and corresponding wheel number or “---” for battery voltage (**See Figure 7.1**). The green dash lines will remain until the sensor senses that the wheel speed is over 12 mph/20 kph or pressure is being added/released from the tire. Sensors may take a few minutes to wake-up. Once the sensors wake-up, the sensor will continue to transmit data to the receiver every minute while moving.

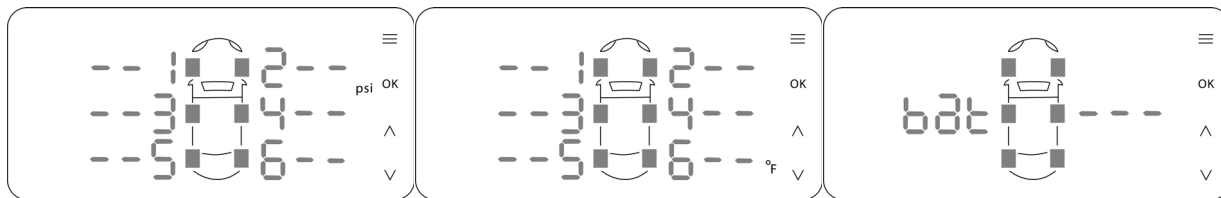

*Figure 7.1 Tire Pressure / Tire Temperature / Vehicle/Trailer Battery Voltage Display Screens*

There are different display modes with different vehicle configurations, see the **Table 7.1** below. Please pay attention to the white number on the actual vehicle tire location and how it refers to the red number tire location on the display on Table 7.1. There may be other custom vehicle configurations in which Table 7.1 does not cover, but the table can be used as a reference on how the tire location on the display will correlate with the actual tire location on a vehicle.

Table 7.1 Vehicle Tire Location on Receiver Display Mode

| Vehicle Tire Location   |   |  |  |   |
|---|---|--|--|---|
|  |  |   |  |  |
| Display Mode  |   |  |  |   |
|  |  |  |  |   |

Table 7.1 Vehicle Tire Location on Receiver Display Mode (continued)

**Vehicle Tire Location**



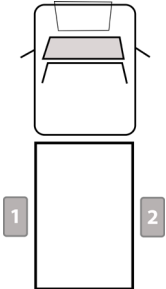
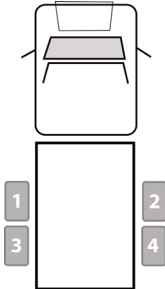
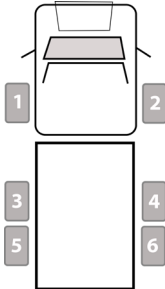
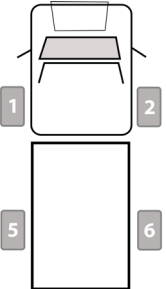
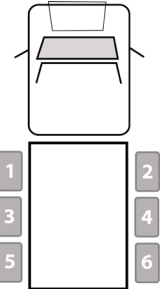
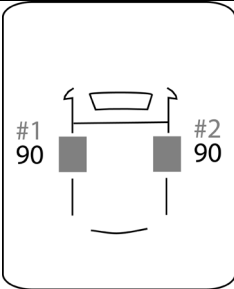
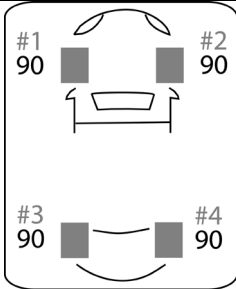
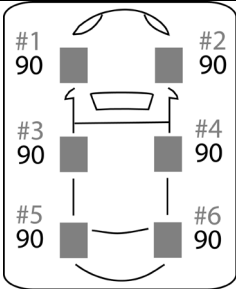
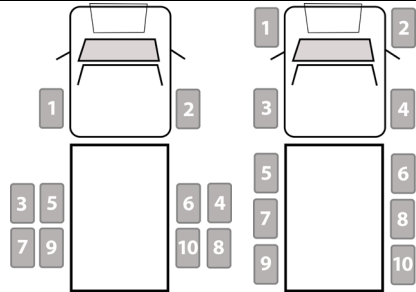
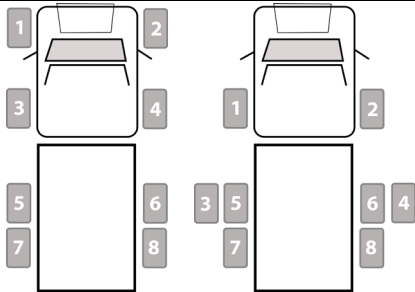
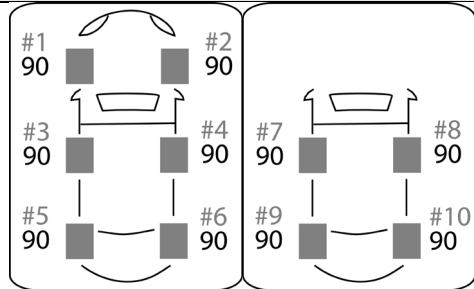
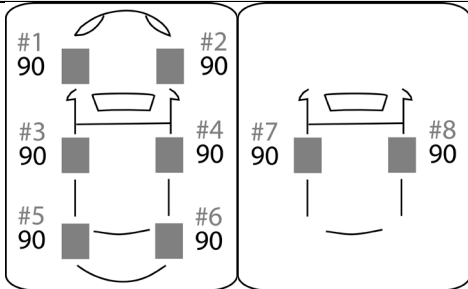

**Display Mode**



During Driving Mode, the receiver will monitor all the installed sensors and the tow vehicle battery voltage. The receiver will alert the user of the following sensor and tow vehicle battery issues:

- **TPMS System Alarm:** indicates that the sensor signal was lost since the receiver has not received a sensor signal from a specific wheel for at least 10 minutes. (Note: This does not activate when the vehicle is stopped.)
- **Sensor Low Battery Power:** indicates that the sensor's battery power status is low.
- **Low Battery Power on the tow Vehicle (12V):** indicates tow vehicle battery voltage  $\leq 11.5V$ .

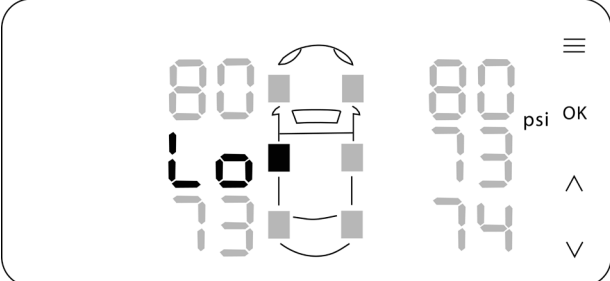
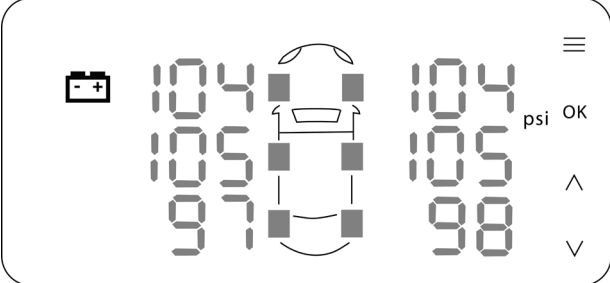
|                                       |   |
|---------------------------------------|---|
| <p><b>TPMS System Alarm Image</b></p> |   |
| <p><b>Alarm Indicators</b></p>        | <ul style="list-style-type: none"> <li>•  alarm symbol will appear on the left side of the display in red</li> <li>• Tire/wheel location will turn red and blink</li> <li>• Sensor pressure/temperature value become "---" and will turn red</li> </ul> |

|  |  |
|--|--|
| <p><b>Sensor Low Battery Power Image</b></p>                   |   |
| <p><b>Alarm Indicators</b></p>                                 | <ul style="list-style-type: none"> <li>• Sensor pressure/temperature value become “Lo” and will turn red</li> <li>• Tire/wheel location will turn red and blink</li> <li>• One beep per second will sound</li> </ul> |
| <p><b>Low Battery Power on the Tow Vehicle (12V) Image</b></p> |    |
| <p><b>Alarm Indicators</b></p>                                 | <ul style="list-style-type: none"> <li>•  alarm symbol will appear on the left side of the display in red</li> </ul>                |

The alarm indicators will continue until the issue is resolved and the condition has returned to normal.

## 7.1 Tire pressure Display: psi, kPa & Bar (Pressure units)

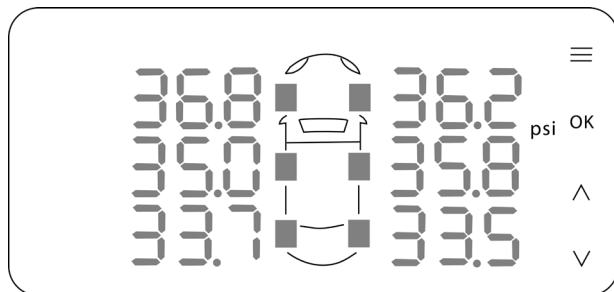

In the Driving Mode, the default value for tire pressure is set to 80 psi (See **Section 8.3 Setting Tire Pressure** to change the default pressure unit and/or value). Below is the default value for each unit of pressure selected:

| Pressure units | Default tire pressure value |
|----------------|-----------------------------|
| kPa            | 552 kPa                     |
| Psi            | 80 psi                      |
| Bar            | 5.5 Bar                     |

Note: When using kPa as the unit of air pressure, the monitor will display “Hi” if the air pressure is over 999kPa. The actual air pressure values will be displayed numerically when the unit of measure selected is in psi or Bar.





During Driving Mode, the receiver will monitor for low and high pressure. The low- and high-pressure alarms are structured by the following parameters:

- **Warning of excessive high tire pressure** indicates tire pressure has been risen to 50% or more of the standard tire pressure value set by the user [ $P \geq (1.5 * \text{standard Pressure value})$ ].
- **Warning of excessive low tire pressure** indicates that the tire pressure has decreased by 20% or more of the standard tire pressure value set by the user [ $P \leq (0.8 * \text{standard Pressure value})$ ].

When these alarm parameters are met, the following alarm indicators will alert the user of a tire pressure issue:

|   |   |
|---|---|
| <p><b>Tire Pressure Alarm Image</b></p> |   |
| <p><b>Alarm Indicators</b></p>          | <ul style="list-style-type: none"> <li>•  alarm symbol will appear on the left side of the display in red</li> <li>• Tire/wheel location will turn red and blink</li> <li>• Pressure value will turn red</li> <li>• One beep per second will sound</li> </ul> |

The alarm indicators will continue until the issue has been resolved and the pressure value(s) have returned to normal range.

The default setting for the display in Driving Mode is to cycle between the tire pressure, tire temperature and vehicle/trailer battery voltage screens. If the user would like to monitor the tire pressure values only on the display screen, press  when the tire pressure screen is displayed. Press  again to return to cycling between screens.

## 7.2 Tire Temperature Display: °F & °C (Temperature units)

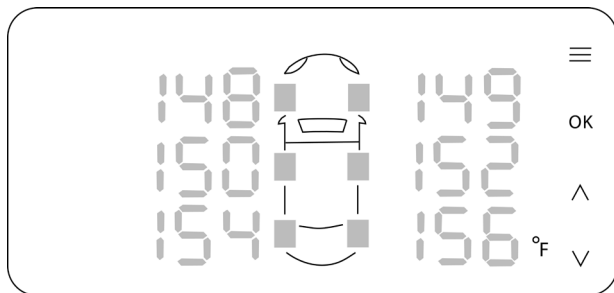

In Driving Mode, the default value for tire temperature is set to 176 °F (See **Section 8.4 Setting Tire Temperature** to change the default temperature unit and/or value).

Below is the default value for each unit of temperature selected:

| Temperature units | Default tire temperature value |
|-------------------|--------------------------------|
| °C                | 80 °C                          |
| °F                | 176 °F                         |



During Driving Mode, the receiver will monitor for high temperature. If the tire temperature rises above the standard tire temperature value set by the user [ $T \geq$  (standard temperature value)], then the following alarm indicators will alert the user of a high tire temperature issue:

|                                     |  |
|-------------------------------------|--|
| <b>Tire Temperature Alarm Image</b> |  |
| <b>Alarm Indicators</b>             | <ul style="list-style-type: none"> <li>•  alarm symbol will appear on the left side of the display in red</li> <li>• Tire/wheel location will turn red and blink</li> <li>• Temperature value will turn red</li> <li>• One beep per second will sound</li> </ul> |

The alarm indicators will continue until the issue has been resolved and the temperature value(s) have returned to normal range.

## <IMPORTANT 6>

Typically, low tire pressure will generate high temperature. If you are seeing a high temperature warning but no low tire pressure warning, then the sensor is detecting high temperature from metal components that transfer heat faster than rubber. This indicates that the tire/wheel location may have a bearing or brake issue and should be checked as soon as possible.

The default setting for the display in Driving Mode is to cycle between the tire pressure, tire temperature and vehicle/trailer battery voltage screens. If the user would like to monitor the tire temperature values only on the display screen, press  when the tire temperature screen is displayed. Press  again to return to cycling between screens.

## 7.3 Vehicle/Trailer Battery Voltage

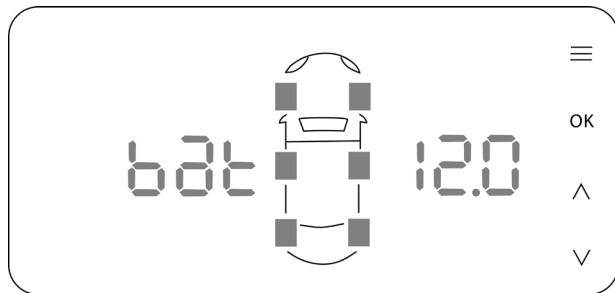



In Driving Mode, the user can monitor the vehicle/trailer battery voltage of the battery that the repeater is installed and connected to. On the battery voltage display screen, the “bat” to the left of the vehicle diagram stands for battery and the battery voltage value is displayed to the right side of the vehicle diagram. The repeater requires 12/24V battery for proper operation.

If the vehicle/trailer battery voltage drops below 11.5 or 23V, the following alarm indicators will alert the user of a low battery voltage issue:

|   |  |
|---|--|
| <p><b>Low Battery Power in the Vehicle/Trailer Battery (12/24V) Image</b></p> |  |
| <p><b>Alarm Indicators</b></p>  | <ul style="list-style-type: none"> <li>• The battery voltage value will display in red text</li> </ul> |

The alarm indicator will continue until the issue has been resolved and the vehicle/trailer battery voltage has returned to normal range.

The default setting for the display in Driving Mode is to cycle between the tire pressure, tire temperature and vehicle/trailer battery voltage screens. If the user would like to monitor the vehicle/trailer battery voltage

only on the display screen, press  when the vehicle/trailer battery voltage screen is displayed. Press  again to return to cycling between screens.

#### **7.4 Alarm Volume Adjustment**

During the Driving Mode, press  or  to adjust the alarm volume.

#### **7.5 Mute Alarm**

When an alarm sound goes off, the user has the option of muting the alarm. Press  to mute the alarm. The alarm will sound again if the receiver power is reset, another alarm occurs on the same wheel or an alarm occurs on other wheels.



#### **7.6 Screen OFF**

Hold  for 3 seconds to turn off the screen, the receiver is still working in the background.

#### **7.7 Screen ON**

Press any button to turn on the screen, the screen will also turn on when a tire alarm occurs.

## 8. Settings Mode Menu:

To enter the Settings Mode menu from Driving Mode, press and hold the  for 3 seconds. At any time, press and hold  for another 3 seconds to switch back to Driving Mode. User will have 60 seconds to make any changes for each TPMS parameter setting. If no change is made within that period, a long tone beep will sound from the receiver to warn the user that the setting was not programmed, and receiver display will return to Driving Mode.

The receiver supports TPMS parameter settings for up to three (3) vehicle and/or trailer combinations. Follow the settings list below to configure the relative parameters for each vehicle and/or trailer combination. **Fig 8 Settings Mode Menu Screen Chart** shows the sequence of Setting Mode screens.

### 8.1 Vehicle Selection

### 8.2 Setting the Number of Wheels to Display

### 8.3 Setting Tire Pressure

### 8.4 Setting Tire Temperature

### 8.5 Tire Sensor ID Pairing to the Receiver

### 8.6 Setting Tire Position on the Receiver

Figure 8 Settings Mode Menu Screen Chart

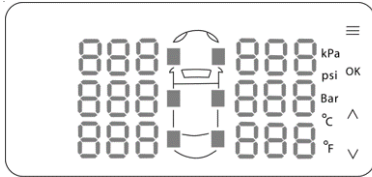

Initial Settings Mode Menu Screen

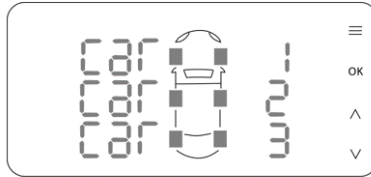

8.1 Vehicle Selection

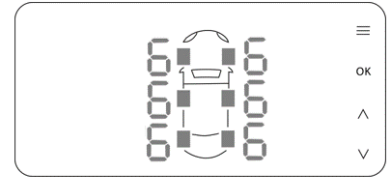

8.2 Setting the Number of Wheels to Display

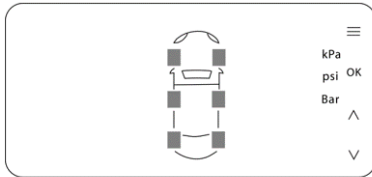

8.3 Setting Tire Pressure

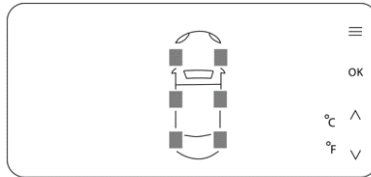

8.4 Setting Tire Temperature

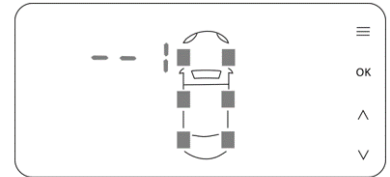

8.5 Tire Sensor ID Pairing to the Receiver

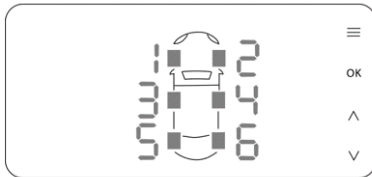

8.6 Setting Tire Position on the Receiver





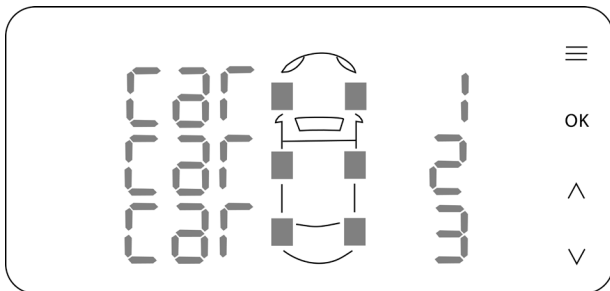

## 8.1 Vehicle Selection

The receiver can store the ID sensors for up to three (3) vehicle and/or trailer combinations. The Vehicle Selection allows you to view, set, or modify the TPMS parameter settings of a specific vehicle and/or trailer combination. The receiver defaults to monitor Vehicle Selection “CAR 1”. The first step is to select the vehicle and/or trailer combination that you would like to program.

- 8.1.1 Press and hold  for 3 seconds to enter the Settings Mode Menu. The first screen to display in the Settings Mode Menu is the Vehicle Selection TPMS parameter setting. The Vehicle Selection will display as shown below list “CAR 1”, “CAR 2” and “CAR 3”.



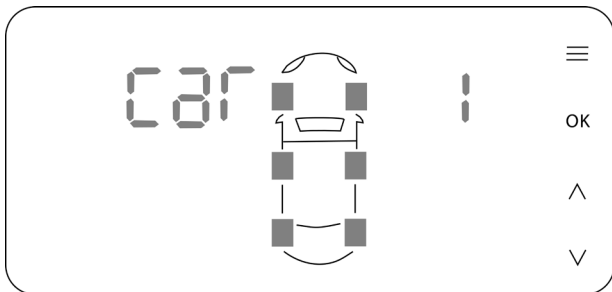

- 8.1.2 Press , then “CAR 1” will blink. Press   to select the vehicle and/or trailer combination you would like to program or select to view in Driving Mode, then press  to

confirm Vehicle Selection and a short beep will sound. The receiver will automatically go to the next TPMS parameter setting “8.2 Setting the Number of Wheels to Display”. (Note: If no Vehicle Selection is made within 60 seconds, the receiver will beep for a long tone to warn that the last setting was not stored in the receiver and the display will return to Driving Mode.)



**8.1.3** If this is your first time setting up the TPMS Retrofit kit, you will need to set the TPMS parameter settings for “CAR 1”, starting with Step 8.2 through 8.4. (Note: Step 8.5 is necessary only when adding additional sensors NOT included in this TPMS kit or replacing sensors and step 8.6 is for a tire rotation). If only selecting the Vehicle Selection to monitor in Driving Mode and no other TPMS parameter settings need to be modified, press and hold  for 3 seconds to return to the Driving Mode Menu.

**8.1.4** When “CAR 1” settings are complete, you can go back to the Vehicle Selection to repeat setting procedures 8.1.2 and 8.1.3 for “CAR 2” and “CAR 3”.

- 8.1.5** After TPMS parameter settings have all been programmed for each Vehicle Selection, repeat step 8.1.2 to select the vehicle and/or trailer combination you would like to monitor and then press and hold  for 3 seconds to switch back to Driving Mode. Once the receiver has returned to Driving Mode the TPMS parameter settings programmed for the selected Vehicle Selection will be monitored.
- 8.1.6** For more than one programmed Vehicle Selection in the receiver, the user will need to go to the Settings Mode Menu to manually select the programmed Vehicle Selection (CAR 1, CAR 2, CAR 3) they would like to monitor on the receiver. In Driving Mode, the receiver will only display the paired sensors' data of the selected Vehicle Selection set by the user. If user switches to another vehicle/trailer that has different sensor data programmed on another Vehicle Selection in the same receiver, the user will need to return to the Vehicle Selection setting to select the correct vehicle/trailer to monitor on the receiver.
- 8.1.7** If you would like to skip the Vehicle Selection setting to go to other parameter settings in the Setting Mode Menu, you can press   to move to the next TPMS parameter setting.



## **8.2 Setting the Number of Wheels to Display**

The receiver can monitor up to ten (10) tires for each programmed vehicle selection. The Setting the Number of Wheels to Display setting allows you to view, set, or modify the number of wheels monitored on the receiver for the selected vehicle selection. The receiver will be preset to either four (4) or six (6) wheels to display based on the number of TPMS sensors included in the TPMS Retrofit Kit for “CAR 1”. The default wheel number to display is six (6) wheels for “CAR 2” and “CAR 3”. If the default Number of Wheels to Display for “CAR 1” is correct and you will NOT be installing additional TPMS sensors to “CAR 1”, then you



can press  to move to the next TPMS parameter setting. If you are setting up the Number of Wheels to Display for “CAR 2” or “CAR 3” for the first time, or installing additional TPMS sensors to any of the vehicle selections, follow the instructions below:

**8.2.1** The Number of Wheels to Display setting screen will show the default wheel number.

**8.2.2** Press  and the wheel number will blink.

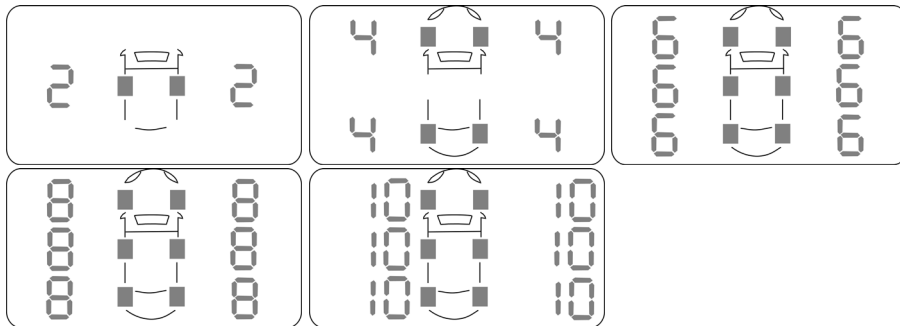
**8.2.3** Press   to increase/decrease the number of wheels to display. The number of wheels to display increase/decrease in increments of two.



**8.2.4** Press  to confirm your selection and a short beep will sound, indicating that the setting has been saved. The receiver will automatically go to the next TPMS parameter setting: “8.3 Setting Tire Pressure” for that vehicle selection. If no further parameter settings are required, you can hold the  for 3 seconds to switch back to Driving Mode. (Note: If the Number of Wheels to Display is NOT made within 60 seconds, the receiver will beep for a long tone to warn that the last setting was not stored to the receiver and the display will return to Driving Mode.)

### 8.3 Setting Tire Pressure Units

The receiver can monitor and display tire pressure in three (3) different units of pressure: kPa, psi, and Bar. The Setting Tire Pressure Units setting allows the user to view, set, or modify the unit of pressure and standard pressure value for each set of tires monitored on the receiver for the selected vehicle selection. If the Tire Pressure Units setting is skipped, the default tire pressure values listed in **step 8.3.3** will be used. Depending on the type of tires that are being monitored the standard tire pressure value will vary. Below is a general tire pressure inflation guideline to help determine the standard tire pressure value to be set based on tire type:

- **For Trailer Tires**, which will have an “ST” in front of the tire size, tire industry experts recommend using the maximum inflation pressure indicated on the sidewall of the tire to provide the full load carrying capacity. You can also reference the tire inflation pressure guidelines on the chassis plate.
- **For Passenger Vehicle Tires**, the tire pressure should be inflated to the vehicle’s recommended tire pressure located on the vehicle door edge or in the owner’s manual.

The Tucson TPMS monitors the following two tire pressure alerts:

- **High Pressure** – indicates tire pressure has risen 50% or more above the standard tire pressure value set by the user.
- **Low Pressure** – indicates tire pressure has fallen 20% or more below the standard tire pressure value set by the user.

Based on the general tire pressure inflation guideline and the system's pressure alert parameters, you can determine the standard tire pressure value to set for each set of tires using the following formula:

| Type of Tire           | Recommended Tire Pressure | Low Pressure Warning       | Standard Tire Pressure Value | High Pressure Warning     |
|------------------------|---------------------------|----------------------------|------------------------------|---------------------------|
| Trailer Tire           | 80 psi (MAX)              | $80 \times 0.8 = 64$ psi   | 80 psi                       | $80 \times 1.5 = 120$ psi |
| Passenger Vehicle Tire | 32 psi                    | $32 \times 0.8 = 25.6$ psi | 32 psi                       | $32 \times 1.5 = 48$ psi  |

### <IMPORTANT 7>

The standard tire pressure value is the "cold" inflation pressure that the tire is designed to hold. It is also important to remember that the vehicle/trailer's recommended tire inflation pressure is always to be measured and set when the tire is "cold". Cold conditions are defined as early in the morning before the day's ambient temperature, sun's radiant heat or the heat generated while driving causes the tire pressure to increase.

Once you have determined the standard tire pressure values that you would like to set, follow the instructions below:

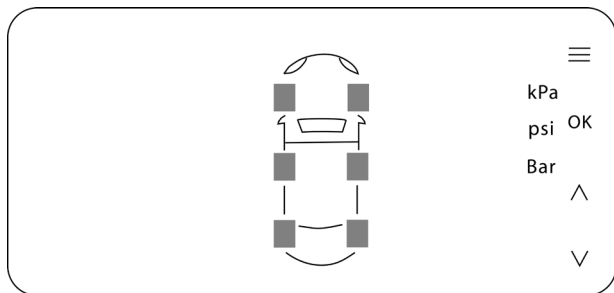





**8.3.1** The Tire Pressure Units setting screen will list “kPa” “psi” and “Bar” pressure units on the upper-right hand corner of the display screen.

**8.3.2** Press  and the pressure units will blink. Pressure unit “psi” will be selected by default. Press   to select the desired pressure unit, then press  to confirm and a short beep will sound.

- 8.3.3** Once the desired pressure unit is selected, the standard tire pressure value can be programmed for each set of wheels. Below is chart of the default tire pressure values per pressure unit:

| Pressure units | Default tire pressure value |
|----------------|-----------------------------|
| kPa            | 552 kPa                     |
| Psi            | 80 psi                      |
| Bar            | 5.5 Bar                     |

Note: When using kPa as the unit of air pressure, the monitor will display “Hi” if the air pressure is over 999kPa. The actual air pressure values will be displayed numerically when the unit of measure selected is in psi or Bar.

- 8.3.4** The tire pressure value of the first set of wheels will begin to blink. Press   to increase/decrease pressure value to the standard tire pressure value, then press  to set the pressure value.
- 8.3.5** The tire pressure value of the next pair of wheels will begin to blink. Repeat step 8.3.4 until each pair of wheels has been programmed to the standard tire pressure value.
- 8.3.6** When you have completed the Tire Pressure Units settings for all tires, you will hear a short beep, indicating that the set tire pressure values have been saved successfully. The receiver will automatically go to the next TPMS parameter setting: “8.4 Setting Tire Temperature Units” for that vehicle selection. If no further parameter settings are required, you can hold the  for 3 seconds to switch back to Driving Mode. (Note: If the Tire Pressure Units is NOT programmed within 60



seconds, the receiver will beep for a long tone to warn that the last setting was not stored to the receiver and the display will return to Driving Mode.)

## 8.4 Setting Tire Temperature Units

The receiver can monitor and display tire temperature in either °F or °C. The Setting Tire Temperature Units setting allows the user to view, set, or modify the unit of temperature and standard temperature value for each set of tires monitored on the receiver for the selected vehicle selection. If the Tire Temperature Units setting is skipped, the default tire temperature values listed in **step 8.4.3** will be used. Generally, the default temperature setting is sufficient, but depending on your circumstances you may want to reduce standard temperature value to common tire temperature settings of 158°F or 167°F (70°C or 75°C).

Once you have determined the standard tire temperature values that you would like to set, follow the instructions below:

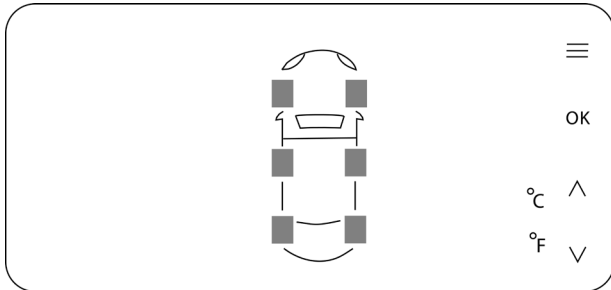

- 8.4.1** The Tire Temperature Units setting screen will list “ °C ” and “ °F ” temperature units on the lower-right hand corner of the display screen.

**8.4.2** Press  and the temperature units will blink. Temperature unit “ °F ” will be selected by default. Press   to select desired temperature unit, then press  to confirm and a short beep will sound.

**8.4.3** Once the desired temperature unit is selected, the standard tire temperature value can be programmed for each set of wheels. Below is chart of the default tire temperature values per temperature unit:

| Temperature units | Default tire temperature value |
|-------------------|--------------------------------|
| °C                | 80 °C                          |
| °F                | 176 °F                         |

**8.4.4** The tire temperature value of the first set of wheels will begin to blink. Press   to increase/decrease to the standard tire temperature value, then press  to set the temperature value.

**8.4.5** The tire temperature value of the next pair of wheels will begin to blink. Repeat step 8.4.4 until each pair of wheels has been programmed to the desired standard tire temperature value.

**8.4.6** When you have completed the Tire Temperature Units settings for all tires, you will hear a short beep, indicating that the set tire temperature values have been saved successfully. The receiver will automatically go to the next TPMS parameter setting: “8.5 Tire Sensor ID Pairing to the Receiver” for that vehicle selection. If no further parameter settings are required, you can hold the



for 3 seconds to switch back to Driving Mode. (Note: If the Tire Temperature Units is NOT programmed within 60 seconds, the receiver will beep for a long tone to warn that the last setting was not stored to the receiver and the display will return to Driving Mode.)

## 8.5 Tire Sensor ID Pairing to the Receiver

### <IMPORTANT 8>

If the Tuson TPMS Retrofit Kit sensors were installed according to **Section 4. TPMS Sensor Installation** and NO additional sensors will be installed for CAR 1, then **Setting 8.5** can be SKIPPED for CAR 1. (**Note:** If installing additional sensors not included in the kit, the “8.5 Tire Sensor ID Pairing to Receiver” MUST be performed to install the additional sensors only.)



To pair the additional tire sensor IDs to the receiver:

- 8.5.1** The receiver will need to be placed close to each tire with a sensor that you would like to pair to the receiver. If the included 12V cigarette lighter cable is not long enough to reach the tire sensors that you would like to pair, you can use the following alternatives to reach the tire sensors:
- 12V extension cord with cigarette plug
  - Tuson Display Power Cable (sold separately) to power the receiver with a 9V battery,
  - 12-Volt AC/DC Power Converter
  - Move the tow vehicle close to the trailer
- 8.5.2** If moving the tow vehicle close to the trailer, disconnect the tow vehicle from the trailer electrically and physically if it is connected. Move the tow vehicle with the receiver unit installed close enough to the trailer or vehicle wheels that receiver can be placed near the sensors installed in the tires.

**8.5.3** Move the receiver close to the wheel of the vehicle/trailer wheel to be paired

**<IMPORTANT 9>**

You do NOT have to pair the sensors that were included in the Tuson TPMS Retrofit Kit if you followed Section 4. For example, if you purchased a 6-wheel TPMS Retrofit Kit and 2 additional sensors to monitor 8-wheels total on CAR 1, you will need to pair wheel location 7 and 8 ONLY since 1-6 will already be paired to the receiver.

**8.5.4** If the Setting Mode Menu timed out and returned to Driving Mode Menu, then hold  for 3 seconds and press   until you reach the Tire Sensor ID Pairing setting screen. (Note: The last selected vehicle selection will be the one that you are pairing. If it is not the vehicle selection that you would like to perform the Tire Sensor ID Pairing, then you will need to perform Setting 8.1 again.)

**8.5.5** The Tire Sensor ID Pairing screen will show "--1" at the left-front tire sensor by default.

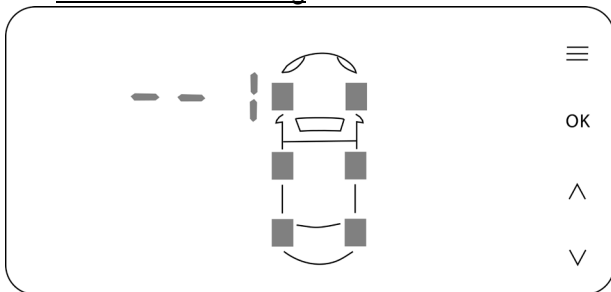

- 
- 8.5.6 Press  and the "--1" will blink. Press  to navigate to tire location number that you would like to pair. (**Note:** One or two red dashes "--" and a number (1-10) are used to indicate the tire location on a Vehicle Selection. Tire location numbers 1-10 on the Tire Sensor ID Pairing screen will be the same regardless of the Vehicle Selection.)
- 8.5.7 Once you are on the selected tire location to pair and while the tire location is blinking, begin deflating or inflating the corresponding tire. Each tire will have 120 seconds to complete the Tire Sensor ID Pairing after the blinking starts. (**Note:** The receiver will emit a long beep and go back to the Tire Sensor ID Pairing if it DOES NOT receive any signal from tire deflation within 120 seconds.
- 8.5.8 A short beep will sound and the sensor's ID number will appear on the receiver indicating that the sensor signal was received and properly paired to the receiver.
- 8.5.9 Inflate tire back to standard pressure level.
- 8.5.10 Press  to move to the next tire location you would like to pair.
- 8.5.11 After completing the Tire Sensor ID Pairing for the vehicle selection, press  and the receiver will automatically go to the next TPMS parameter setting: "8.6 Setting the Tire Position on the Receiver"
-

<IMPORTANT 10>

After you finished the Tire Sensor ID Pairing for a vehicle selection. You can review paired sensor ID#s to each vehicle selection & wheel location to confirm whether each sensor ID and tire location was properly paired to the vehicle selection and matches the sensor ID#s that listed in Section 12.3. Turn the receiver

power off, then press and hold  button while powering on the receiver. The following sequence of screens will appear:

- **Firmware version**

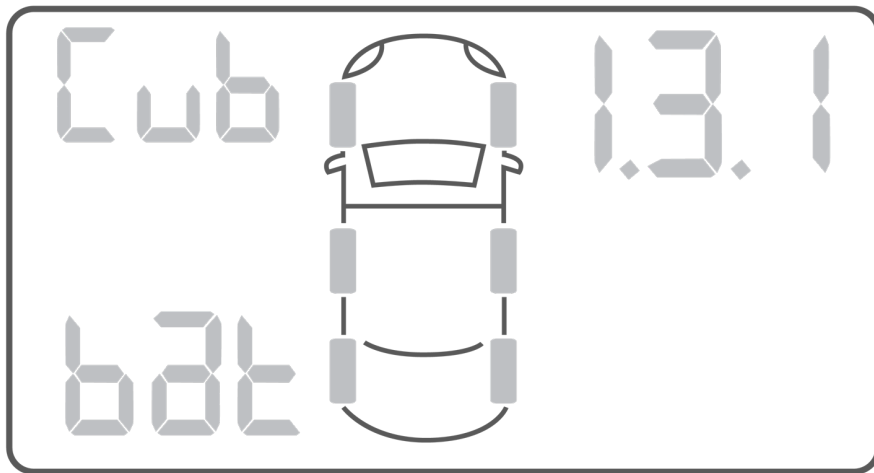

- Vehicle Selection/Tire Location/Sensor ID# Screen Cycle

Vehicle Selection #

1 = CAR 1

2 = CAR 2

3 = CAR 3

Tire Selection

#1 - 10

Sensor ID #

8 digit number

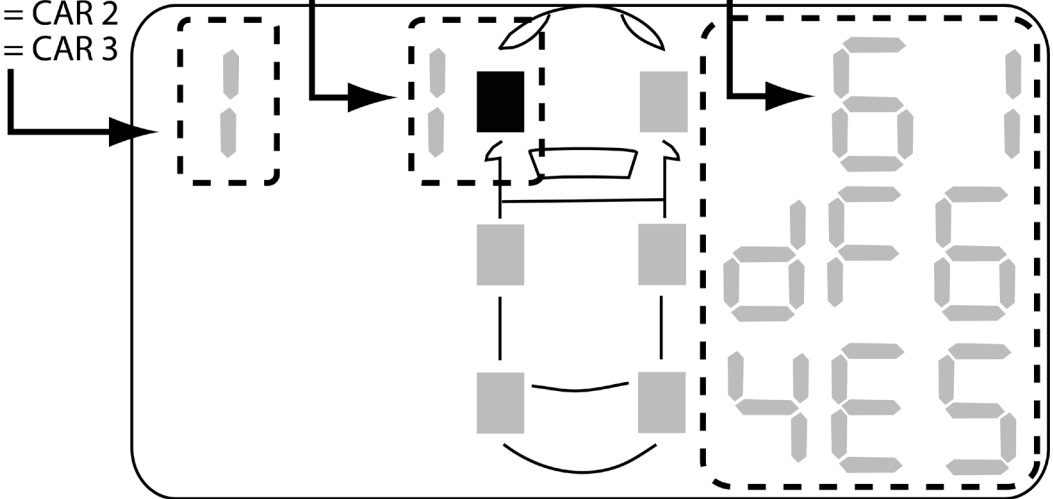

If a sensor did not properly pair to the receiver, then instead of seeing the sensor ID# on the right side of the screen, you will see a “0” followed by the vehicle selection# and the tire location# repeated on both the second and third row (Note: For tire location 10, “A” will be repeated in second and third row).

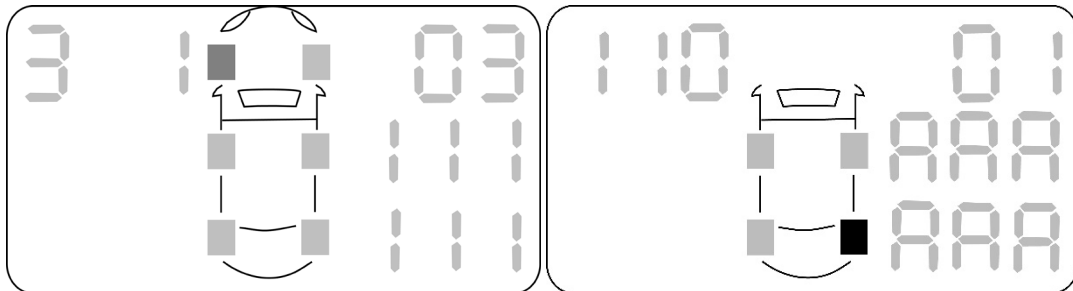



If after performing the sensor ID# review, you noticed that some sensor ID#s were reversed and in the incorrect tire location (i.e. paired sensor ID with wheel orientation mark **5** in tire location 6 on receiver, but sensor is actually installed in tire location 5 and vice versa), then return to the Settings Mode Menu and go to Setting 8.6 Setting the Tire Position on the Receiver to swap the tire position to show the correct sensor ID in the right tire location on the receiver.

After you finish reviewing and confirming the paired sensor ID#s to each vehicle selection & wheel location and everything is correct, you are all set and ready to use the Tuson TPMS Retrofit Kit. Congratulations!









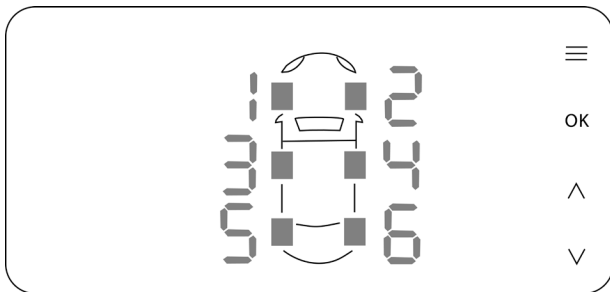

## 8.6 Setting the Tire Position on the Receiver

The Setting the Tire Position on the Receiver TPMS parameter setting is available to the user when performing a tire rotation or when sensors are incorrectly paired to the receiver and need to be swapped. Once you have determined the tire locations that you would like to swap, follow the instructions below:

- 8.6.1 Press and hold  for 3 seconds to enter the Settings Mode Menu. Follow Setting 8.1 to select the vehicle selection that you need to perform the tire position swap, then press  twice to go to the Setting the Tire Position on the Receiver screen.
- 8.6.2 The Setting the Tire Position on the Receiver screen shows the numbered tire positions for each tire sensor on the receiver for the vehicle selection as pictured below.



- 8.6.3 Press  to enter tire position rotation mode, digit “1” will blink by default. Then press   to select the original tire position which needs to be changed and then press  again, and the selected digit at that selected position will turn green and the consecutive digit will begin to blink. (**Note:** If no change is made in this mode for 60 seconds, the receiver will beep a long tone to warn that setting has not been completed successfully and default back to Driving Mode automatically.)
- 8.6.4 Then press   to select digit of the new tire position to which you want to move the selected original tire position to, and press  to confirm, the digit at the new position will also turn green.
- 8.6.5 The digits at both exchanged positions will remain displayed in green for 3 seconds to show which 2 tires are exchanged. Then the chosen digits will automatically turn back to red.
- 8.6.6 Then the screen will show the new positions. If you need to exchange more than one pair of tires, press  to repeat the procedure.
- 8.6.7 Once you have completed rotating tire positions on the receiver press and hold  for three seconds and the receiver will go to Driving Mode.

## 9. Alarm Warning and Display Symbols

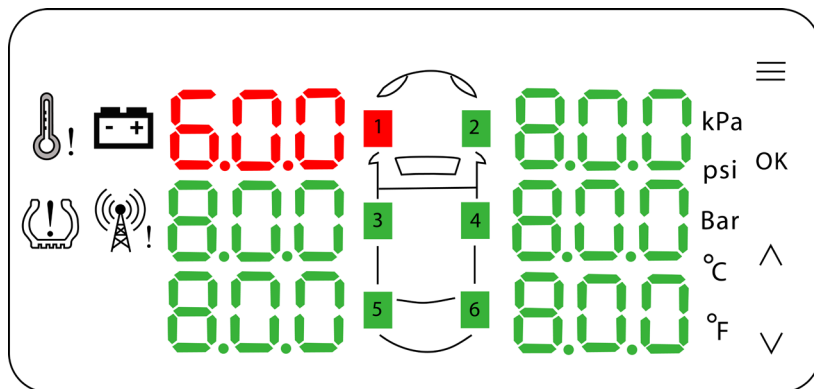



The Tuson TPMS system is designed to detect any pressure, temperature or trailer battery values that are above or below the set limits, those values that are outside the set limit will change from green to red values and an alarm display symbol will appear (some alarms are accompanied by a sound alert) to indicate an issue has been detected. These alarm indicators will continue until issue has been addressed and the values return to an acceptable range. For a detailed chart of the all the alarm messages please see **Section 9.1 Alarm Display Symbols Key**.



Below is a list of the Tire Sensor Alarm Warnings:

- **Warning of excessive high tire pressure** indicates tire pressure has been risen to 50% or more of the standard tire pressure value set by the user.

- **Warning of excessive low tire pressure** indicates that the tire pressure has decreased by 20% or more of the standard tire pressure value set by the user.
- **Warning of excessive tire temperature** indicates that the tire temperature has risen over the standard tire temperature value set by the user.
- Environmental driving conditions could be a factor for tire pressure changes, please go to a service shop to perform tire pressure adjustments to avoid the occurrence of false alarms. Be sure to maintain proper tire pressure in all of your tires for the safest and most cost-effective performance of for your tires.

## 9.1 Alarm Display Symbols Key

| Alarm            | Definition   | Symbol  | Alarm Sound           |
|------------------|--|---|-----------------------|
| Low Pressure     | $P \leq (0.8 * \text{standard Pressure value})$ or $\leq 150$ kPa, take the bigger value |  | One Beep (per second) |
| High Pressure    | $P \geq (1.5 * \text{standard Pressure value})$  |  | One Beep (per second) |
| High Temperature | $T \geq (\text{standard temperature value})$   |  | One Beep (per second) |

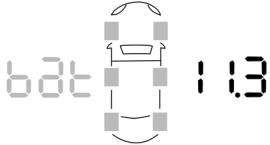
| Alarm                                      | Definition   | Symbol   | Alarm Sound           |
|--|--|--|-----------------------|
| TPMS System Alarm                          | Sensor signal lost. A sensor's signal was not received for at least 10 minutes. Not activated when vehicle is stopped. |   | None                  |
| TPMS Sensor Low Battery Power              | Sensor battery is in low battery power status  |   | One Beep (per second) |
| Low Battery Power on the tow Vehicle (12V) | Battery voltage at the tow vehicle $\leq 11.5V$  |   | None                  |
| Low Battery Power on the Trailer (12/24V)  | Battery voltage at the trailer $\leq 11.5V$ or $\leq 23V$  |  | None                  |

## 10. Troubleshooting

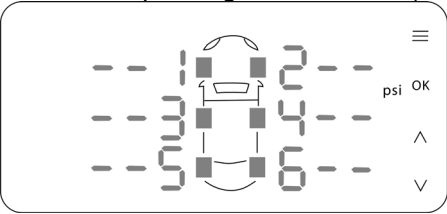
| Issue  | Probable Causes  | Solution   |
|--|--|--|
| <p><b>Tire Sensor ID Paring failed</b><br/>(TPMS alarm with a long beep in rapid deflation learning setting)</p>   | <ul style="list-style-type: none"> <li>● Wireless signal interference</li> <li>● Tire air pressure is not deflated enough</li> </ul>   | <ul style="list-style-type: none"> <li>● Move receiver to another area</li> <li>● Keep deflating the tires for 20~30 seconds</li> </ul>  |
| <p><b>Pressure anomaly warning</b><br/>(TPMS alarm with short beeps)</p>   | <ul style="list-style-type: none"> <li>● Low tire pressure</li> </ul>  | <ul style="list-style-type: none"> <li>● Please inflate the tires to the correct pressure to prevent an erroneous alarm</li> </ul>   |
| <p><b>No signal received</b><br/>(Screen shows pressure and temperature as green dash lines “- -” and corresponding wheel number)</p>  | <ul style="list-style-type: none"> <li>● Signal interference.</li> <li>● Vehicle has stopped or is moving too slow</li> <li>● Sensor is damaged or low battery power</li> <li>● Repeater could be damaged</li> </ul> | <ul style="list-style-type: none"> <li>● Move the tow vehicle away from the current area</li> <li>● Pick up speed of over 12 mph/20 kph to “wake up” sensor and continue driving for a few minutes</li> <li>● Go to a qualified service shop for installation of a new sensor on your wheel</li> <li>● Check that the repeater is powered</li> </ul> |

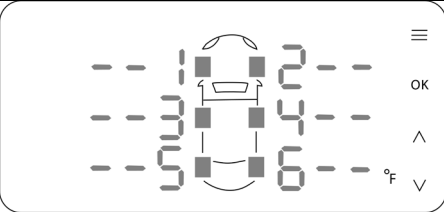
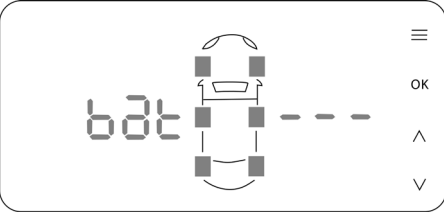
|   |   |   |
|---|---|---|
|    |   |   |
| <p><b>No trailer battery voltage</b><br/>(Screen shows trailer battery voltage as “---”)</p>  | <ul style="list-style-type: none"> <li>● Repeater is not installed</li> <li>● The repeater is installed in a location that prevents the signal from reaching the monitor</li> <li>● The repeater is not connected to the trailer battery</li> <li>● The trailer battery is dead</li> <li>● The tow vehicle is not charging the trailer battery</li> </ul> | <ul style="list-style-type: none"> <li>● Install the repeater to receive trailer battery voltage</li> <li>● Relocate the repeater to a more open location for sending signal to the receiver</li> <li>● Check to see if the repeater is properly connected to the trailer battery</li> <li>● Use a voltmeter to check the trailer battery voltage, charge or replace the dead trailer battery</li> <li>● Check for a blown tow vehicle fuse or bad wiring connection</li> </ul> |

## 11. Customer Service

All product support and warranty coverage are provided by the vendor or distributor from which your product was purchased. Please contact your distributor who originally sold you the Tuson RV Brakes product.

Or contact us:

**US Number:** +1-847-816-8800

**Toll Free:** +1-800-968-8766

**Email:** [InfoRVBrakes@tuson.com](mailto:InfoRVBrakes@tuson.com)

Tuson RV Brakes, LLC

475 Bunker Court

Vernon Hills, IL 60061

[www.TusonRVBrakes.com](http://www.TusonRVBrakes.com)



## 12. Notes

### 12.1 Tuson TPMS Retrofit Kit Information

|                       |  |
|-----------------------|--|
| <b>Serial Number:</b> |  |
| <b>Model Number:</b>  |  |

### 12.2 Vehicle Memory Selection Type

Here you can list each vehicle memory selection stored on the receiver for your reference.

| <b>Vehicle Selection</b> | <b>Setup</b>     | <b># of tires</b> | <b>Size 0.453/0.625"</b> |
|--------------------------|------------------|-------------------|--------------------------|
| Example CAR              | Pickup + Trailer | 4 + 6 = 10        | 0.453"                   |
| <b>CAR 1</b>             |                  |                   |                          |
| <b>CAR 2</b>             |                  |                   |                          |
| <b>CAR 3</b>             |                  |                   |                          |

### 12.3 Sensor ID#s List for Each Vehicle Memory Selection

Each sensor has a unique sensor ID# to identify the sensor to the receiver. The sensor ID#s included in the kit are written under CAR 1 and the numbered list corresponds with the wheel orientation mark (1, 2, ..., 6). Any additional purchased sensor ID#s used with the same receiver will not have a wheel orientation mark on sensor but can be referenced using the wheel orientation mark sticker sheet.

| CAR 1 | CAR 2 | CAR 3 |
|-------|-------|-------|
| 1     | 11    | 21    |
| 2     | 12    | 22    |
| 3     | 13    | 23    |
| 4     | 14    | 24    |
| 5     | 15    | 25    |
| 6     | 16    | 26    |
| 7     | 17    | 27    |
| 8     | 18    | 28    |
| 9     | 19    | 29    |
| 10    | 20    | 30    |

## 12.4 General Notes

## 13. Limited Warranty

Tuson RV Brakes, LLC (Tuson) warrants the Tuson Tire Pressure Monitoring System (TPMS) to be free of defects in material and workmanship for a period not to exceed TWO (2) years from the date of sale to the original consumer, or to the first retail purchaser of a trailer on which the TPMS is installed. Original receipt(s) or other acceptable proof of purchase should be retained by the customer for verification of warranty date. THIS WARRANTY IS NOT TRANSFERABLE.

Tuson's obligations under this warranty shall be limited to crediting the account of a direct buying distributor or OEM trailer manufacturer, replacing or repairing the TPMS products which are determined by Tuson to be defective in material or workmanship, within 60 days of receipt of such product by Tuson. Tuson reserves the right to request the product be returned intact, freight prepaid, PRIOR to processing any claim for warranty.

Warranty claim must be received by Tuson within 30 days of the discovery of the alleged defect, or within 30 days of the expiration of the warranty, whichever is earlier. Covered repairs or replacements will be made at Tuson's expense. Shipment of replacement product or repaired product by Tuson will be via best available ground shipment carrier. Shipments other than by best available ground shipment carrier, must be requested in writing and must be paid for in advance by the customer. Returned product that is found not to be defective, will be returned at sender's expense.

This Warranty shall not include any products which have been improperly installed, installed contrary to installation instructions provided with the product, altered, tampered with or changed in any way, or utilized in a manner not approved by Tuson. This Warranty shall not extend to any defects arising from abuse, misuse, accident, improper wiring, or negligence of the installer or the consumer.

---

EXCEPT AS EXPRESSLY SET FORTH ABOVE, NO OTHER WARRANTY, EXPRESS OR IMPLIED, AT LAW OR IN EQUITY, IS MADE BY TUSON CORPORATION IN RESPECT OF THE PRODUCT, INCLUDING WITHOUT LIMITATION ANY IMPLIED WARRANTY OF MERCHANTABILITY, FITNESS FOR A PARTICULAR PURPOSE OR ANY OTHER WARRANTY, AND ANY SUCH WARRANTIES ARE EXPRESSLY DISCLAIMED.

IN NO EVENT SHALL TUSON BE LIABLE TO PURCHASER OR ANY THIRD PARTY FOR ANY LOST PROFITS, CONSEQUENTIAL, EXEMPLARY, INDIRECT, PUNITIVE, INCIDENTAL, OR SPECIAL DAMAGES OR COSTS (INCLUDING ATTORNEY FEES), OR LOSS OF GOOD WILL RESULTING FROM ANY CLAIM (INCLUDING BUT NOT LIMITED TO ANY CAUSE OF ACTION SOUNDING IN CONTRACT, TORT, NEGLIGENCE, STRICT LIABILITY OR PRODUCT LIABILITY) REGARDING THIS AGREEMENT, EVEN IF THE COMPANY HAS BEEN ADVISED OF THE POSSIBILITY OF SUCH DAMAGES.

Some states do not allow the exclusion or limitation of implied warranties, incidental or consequential damages, so the above limitations or exclusions may not apply to you. This Warranty gives you specific rights. You may have other rights, which vary from state to state.

The logo features the word "TUSON" in a bold, red, serif font. Below the letters are three stylized, dark blue wavy lines that resemble a stylized 'S' or a wave.

**Tuson RV Brakes, LLC**

The Leader In Towable Safety Technology