

# Heavy Duty Truck Module

## Supplemental Installation and Guide

Part Number: RV HDCON-6PIN - Heavy Duty Truck 6 pin converter

Part Number: RV HDCON-9PIN - Heavy Duty Truck 9 pin converter

Part Number: RV HDCON-9PIN-G - Heavy Duty Truck 9 pin green connector converter

Part Number: RV HDCON-16PIN - Heavy Duty Truck 16 pin converter (see additional insert)

### ATTENTION:

Your DirecLink Trailer Brake Controller comes with an Installation and Users Guide. THE SECTIONS OF THIS HD TRUCK MODULE SUPPLEMENTAL INSTALLATION GUIDE REPLACE THE CORRESPONDING SECTIONS OF THE DIRECLINK INSTALLATION AND USER GUIDE WHEN INSTALLING THE ENCLOSED HD TRUCK MODULE.

Tuson's HD Truck Module is ONLY for use with the DirecLink-100 & -200NE brake controllers.

# DirecLink

Trailer Brake Controller



Tuson RV Brakes, LLC  
475 Bunker Court  
Vernon Hills, IL 60061

[www.tusonrvbrakes.com](http://www.tusonrvbrakes.com)

# 1 DirecLink Components

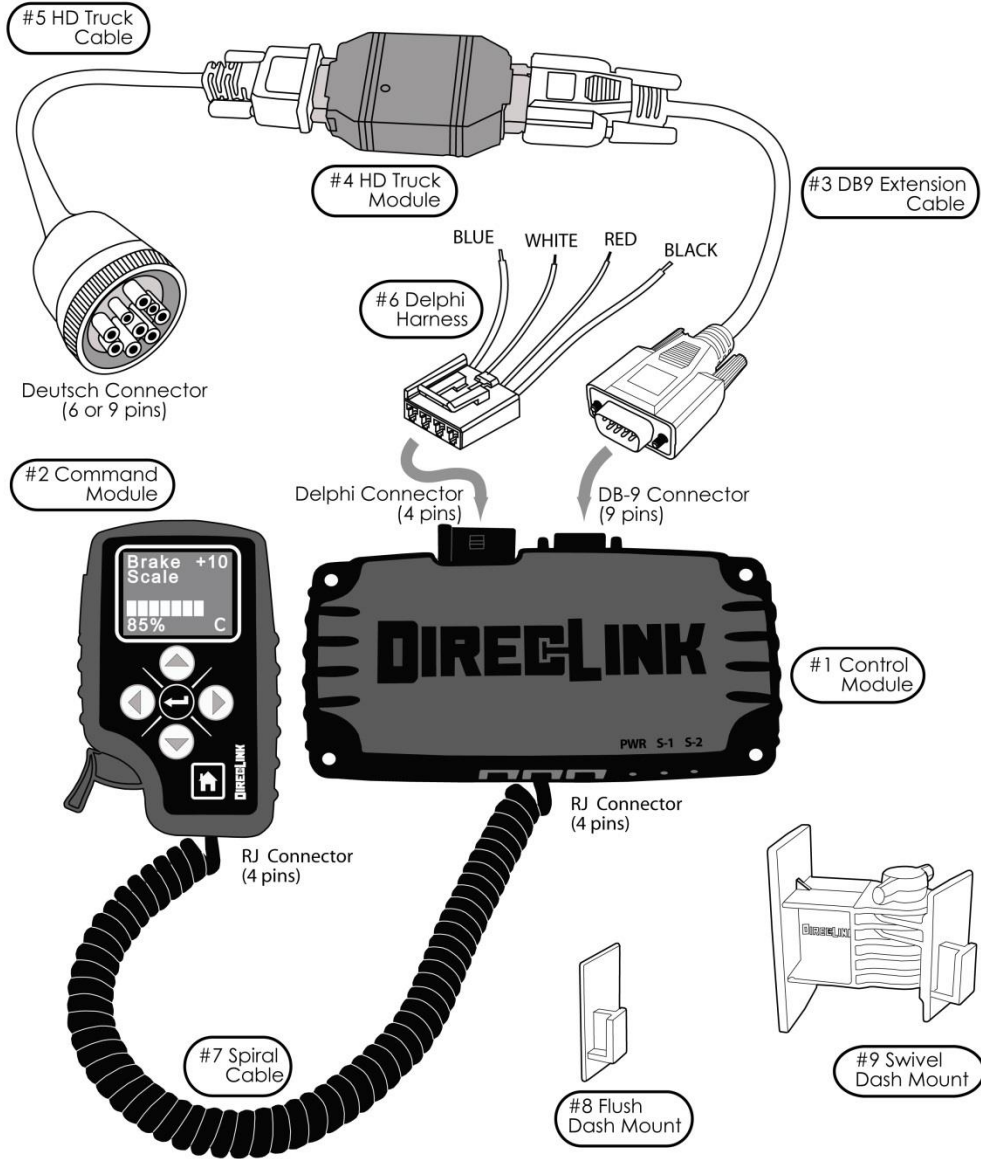

## 1.1 Inside the box

Control Module	#1
Command Module	#2
DB9 Extension Cable	#3
HD Truck Module	#4
HD Truck Cable	#5
Delphi Harness	#6
Spiral Cable	#7
Flush Dash Mount	#8
Swivel Dash Mount	#9
Alcohol wipe	not shown
5 Cable Ties	not shown
Users Manual	not shown

---

## **2 Vehicle Compatibility**

---

Peterbilt

Freightliner

Kenworth

International

Volvo

and others.

---

## 3 Initial Connections and Test

---

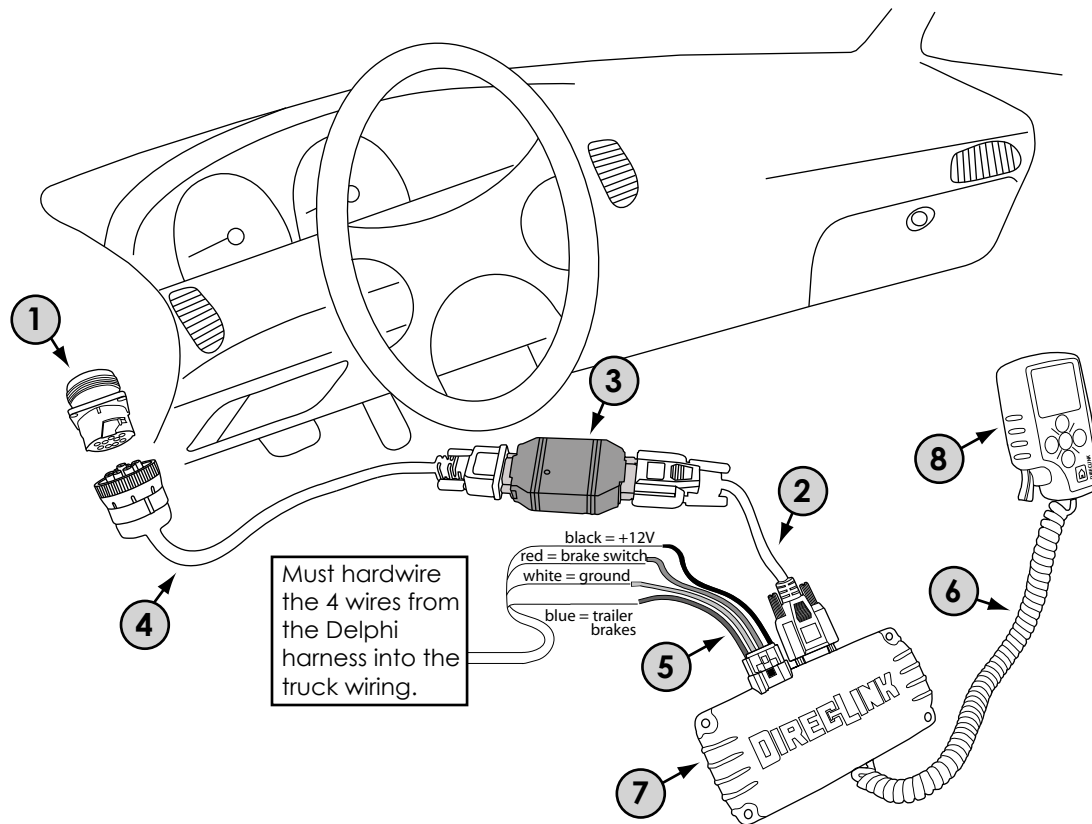

### 3.1 About the Test

The purpose for the initial test, prior to securing the cables and mounting the modules is to verify that the required wiring connections are available and functioning properly. By checking this functionality first, it is easier to make any repairs or corrections while all wiring and components are easily accessible.

### 3.2 Electrical Connections

The required electrical connections are indicated by the numbers in the diagram above:

- 1) **HD TRUCK DEUTSCH CONNECTOR** (already in vehicle)
- 2) **DB9 EXTENSION CABLE** (comes with HD Truck Add-on)
- 3) **HD TRUCK MODULE** (comes with HD Truck Add-on)
- 4) **HD TRUCK CABLE** (comes with HD Truck Add-on)
- 5) **DELPHI 4-WIRE HARNESS** (comes with DirecLink)
- 6) **SPIRAL CABLE** (comes with DirecLink)
- 7) **CONTROL MODULE**
- 8) **COMMAND MODULE**

### 3.3 Connection Sequence

With the vehicle ignition turned OFF and the trailer DISCONNECTED from the vehicle, make the wiring connections in the following order:

- First:** connect the 4 wires from #5 into the truck wiring  
**Second:** connect #1 with #'s 2,3 & 4  
**Third:** connect #'s 2,3 & 4 with #7  
**Fourth:** connect #5 with #7  
**Fifth:** connect #6 with #7  
**Sixth:** connect #6 with #8

---

## 4 Final Installation of Modules and Cables

---

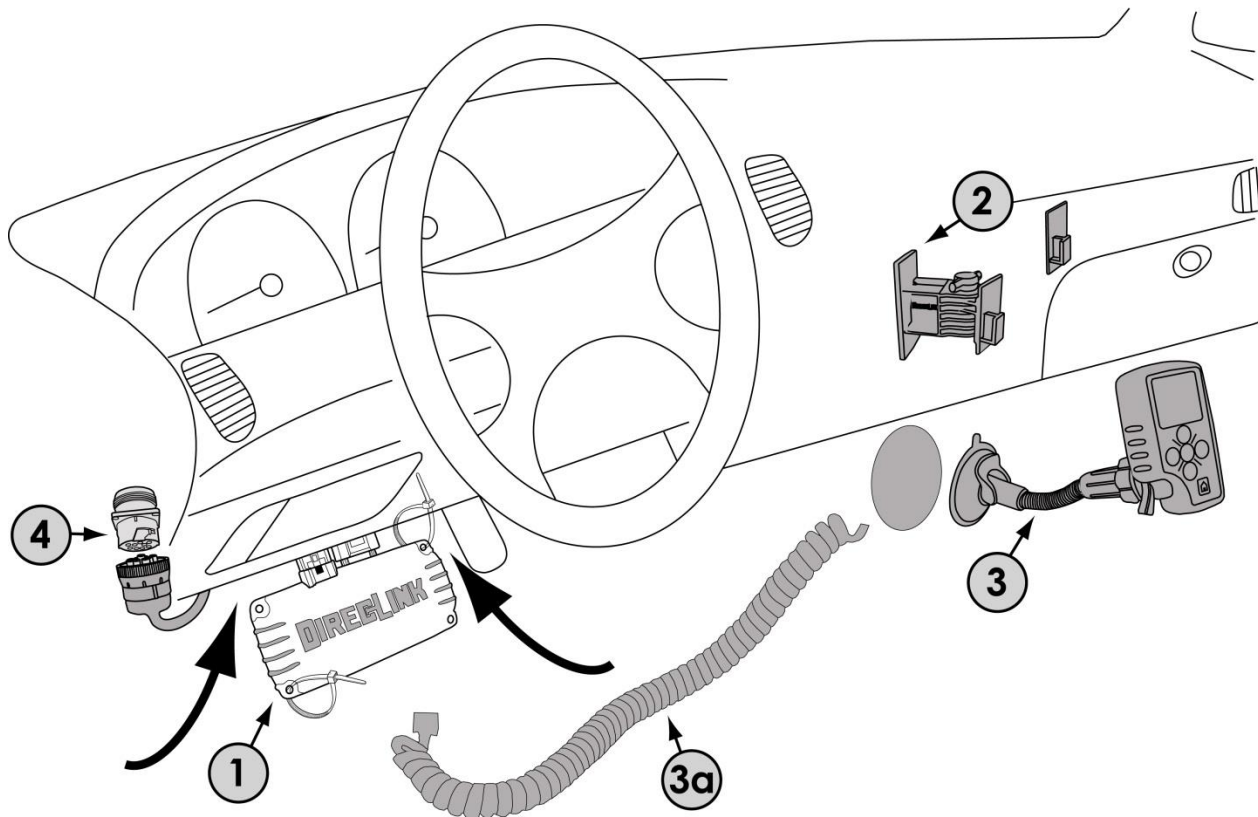

### 4.1 Final Installation Sequence

After successfully completing the initial connections and power-up described in section 3, perform the final installation in the following sequence;

- 1) Using the cable ties provided, secure the HD Truck Module cables, Delphi harness and the control module up underneath the dash with the RJ connectors (phone style connectors) facing out toward the driver to make it easy to plug in the spiral cable. Route the cable ties through at least two of the four corner holes in the control module case and attach them to solid objects under the dash such as support brackets. Be sure all cables are securely fastened to prevent interference with the drivers feet. The control module can be mounted in any orientation without affecting operation.
- 2) Select the location to mount the command module. There are two different styles of dash mounts that come with the DirecLink, flush mount and swivel mount. Both use a peel-off adhesive back for mounting. It is very important to clean the selected mounting surface with an alcohol wipe (included) and let the surface dry before attaching the mount. In selecting a good mounting location be especially aware of dashboard buttons and levers. Make sure that the selected location does not interfere with any of the other dashboard devices.
- 3) After the command module is mounted in an easily viewable and reachable location, attach the spiral cord (#3a) to any of the three RJ connectors on the control module and connect it to the bottom of the command module.
- 4) On some Freightliner models, the trucks diagnostic connector is located on the floor to the left of the drivers seat. In these cases, a longer cable is available to connect the DirecLink to the floor connector.



---

## 4 Final Installation of Modules and Cables

---

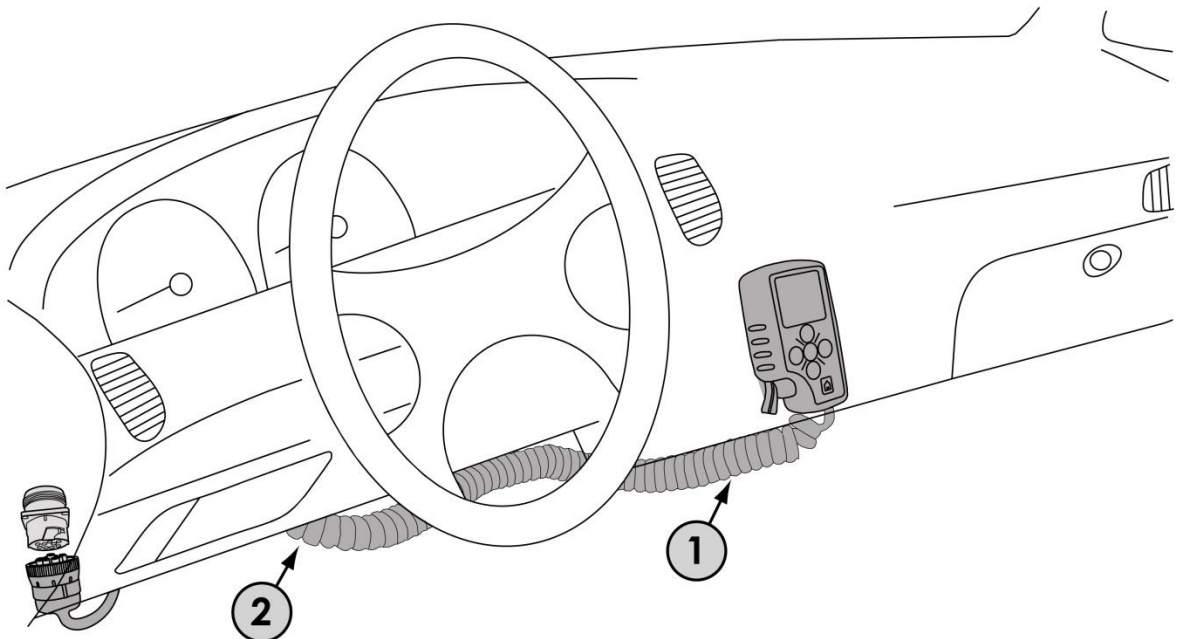

### 4.2 Final Installation Sequence

When the DirecLink is properly mounted, the only parts visible are the command module, spiral cable and possibly the HD Truck Module cable (depending on the location of the truck connector in the vehicle).

- 1) The spiral cord should be routed to the control module in a manner that keeps the cord somewhat tight and against the dash to avoid interfering with the vehicles moving parts or the drivers legs.
- 2) If needed, a cable tie can be used under the dash by the control module to take any excess slack out of the spiral cable. Do not make the spiral cable too tight and keep enough slack to be able to remove the command module from the mount and hold in your hand to operate the buttons.



All wiring must be connected as instructed in this manual for the DirecLink to operate correctly. Failure to connect all the wires correctly may cause a loss of trailer brakes resulting in serious or fatal injury and/or property damage.



The white wire of the Delphi connector (connector #5 in the diagram on page 3) must be connected to the negative terminal of the tow vehicle battery. Improper ground will result in the loss of trailer brakes which may result in serious or fatal injuries and/or property damage.



DO NOT connect the black wire of the Delphi connector (connector #5 in the diagram on page 3) to any vehicle power supply line or fuse panel that could cause a circuit overload or damage to tow vehicle wiring and vehicle electronics.

---

## **5 Limited Warranty**

---

### **Heavy Duty Truck Module Warranty**

Tuson RV Brakes, LLC (hereafter referred to as Tuson) warrants the Heavy Duty Truck Module to be free of defects in material and workmanship, under normal use, for a period of TWO (2) years from the original consumer purchase date. At Tuson's sole option, Tuson will repair or replace the defective product with a like product. Replacement product or parts may include remanufactured or refurbished parts or components. This warranty applies only to the first consumer purchaser, is nontransferable, and is limited to components supplied with the Heavy Duty Truck Module product. The purchase or use of the Heavy Duty Truck Module product constitutes acceptance of the conditions stated in this document. Tuson makes no guarantee, warranty, or representation regarding the suitability or legality of this product. It is the consumer's responsibility to ensure regulatory compliance before purchasing or using this product. The consumer agrees to operate this product in keeping with all laws governing its use. Under no conditions will Tuson be responsible for anything other than the repair or replacement of the original product.

### **Limitation of Liability and Warranty Exclusions**

Tuson's liability is limited to the cost of repair or replacement of the Heavy Duty Truck Module. This limited warranty excludes, but is not limited to damage, deterioration, or malfunction due to negligence, abuse, accident, improper use, misuse, improper installation, failure to follow supplied instructions, alteration, modification, unauthorized repair or attempted repair, external causes, normal wear and tear, or any other cause which does not relate to a product defect. This limited warranty also excludes any incidental, consequential, or other claims, damages, or losses, even if advised of the possibility of such, including against the consumer by any other party. There are no other warranties, express or implied, including implied warranty of merchantability and fitness for a particular purpose. All disputes will be handled in accordance with Illinois state laws.

For assistance with your Heavy Duty Truck Module, please call 800-968-8766 or email to [inforvbrakes@tuson.com](mailto:inforvbrakes@tuson.com).

For more information about the Heavy Duty Truck Module, visit our website at [www.tusonrvbrakes.com](http://www.tusonrvbrakes.com) or [www.direclink.com](http://www.direclink.com).