

KEY FEATURES

Performance

- Three U Shaped 304 SS Burners
- Combined 60,000 BTU/hr
- 865 sq. in. of total grilling surface
 - 685 sq. in. main grilling area
 - 180 sq. in. warming rack
- Overall temperatures range from 250F to 650F
- Heats up to 500F in just 5 minutes

Benefits

- All 304 Stainless Steel Construction
- Fully Assembled Packaging
- LED Backlit Control Knobs (Battery Operated)
- Recessed Foldable Shelves For Compact Footprint
- Push Button Electronic Ignition
- Easy-To-Clean Hidden Residue Tray
- Heavy Duty 8mm Solid 304SS Cooking Grates
- 3-In-1 Cooking - Grilling | Griddle | Charcoal
- NG and LP Options Available
- Limited Lifetime Warranty

Optional Accessories

- FSAOC2 - Outdoor Cover (2 Color Choices)
- FSAGP1 - Griddle Plate
- FSACT1 - Charcoal Tray
- FSART1 - Rotisserie Kit

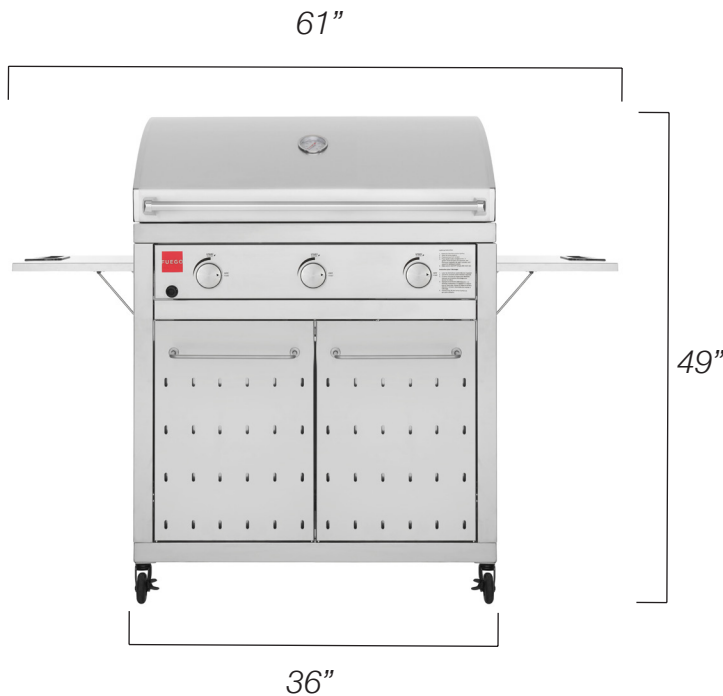

LED Backlit Knobs



Premium Burners



Recessed Side Shelves



Heavy Duty 8mm Grates



Traditional Grilling



Charcoal Grilling



Griddle Plate



Hidden Residue Tray



TECHNICAL SPECS

Dimensions:	36" W 24" D 47" H (Lid Closed) 36" W 29" D 62.5" H (Lid Open)
Package Dimensions:	41" W 30" D 52" H
Package Weight:	212 Pounds
Gas Requirements:	60,000 BTU/hr Natural Gas and Propane Options
Grill Type:	Freestanding
Clearance To Combustibles:	Sides: 24" Rear: 24"

