

KEY FEATURES

Performance

- Three U Shaped 304 SS Burners
- Rear Infrared Rotisserie Burner
- Combined 72,500 BTU/hr
- 865 sq. in. of total grilling surface
 - 685 sq. in. main grilling area
 - 180 sq. in. warming rack
- Overall temperatures range from 250F to 650F
- Heats up to 500F in just 5 minutes

Benefits

- All 304 Stainless Steel Construction
- Fully Assembled Packaging
- LED Backlit Control Knobs (Battery Operated)
- Recessed Foldable Shelves For Compact Footprint
- Push Button Electronic Ignition
- Easy-To-Clean Hidden Residue Tray
- Heavy Duty 8mm Solid 304SS Cooking Grates
- Interior Halogen Lights
- NG and LP Options Available
- Limited Lifetime Warranty

Optional Accessories

- FSAOC2 - Outdoor Cover (2 Color Choices)
- FSAGP1 - Griddle Plate
- FSACT1 - Charcoal Tray
- FSART1 - Rotisserie Kit

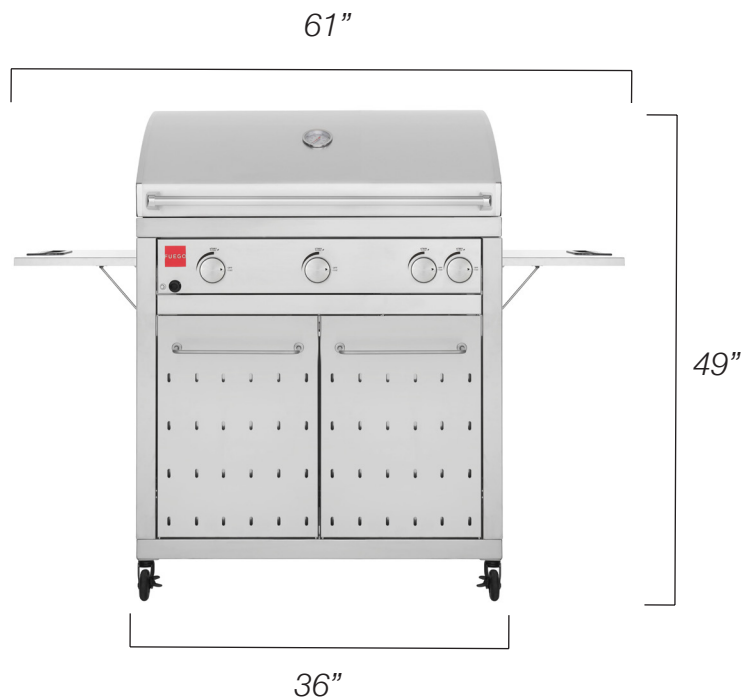

Interior Halogen Lights



Premium Burners



Recessed Side Shelves

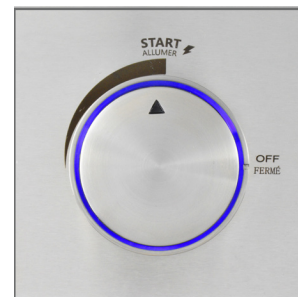

LED Backlit Knobs



Rear Infrared Burner



Griddle Plate



Charcoal Grilling



Traditional Grilling



TECHNICAL SPECS

Dimensions:	36" W 24" D 47" H (Lid Closed) 36" W 29" D 47" H (Lid Open)
Package Dimensions:	41" W 30" D 52" H
Package Weight:	230 Pounds
Gas Requirements:	72,500 BTU/hr - Total Output 60,000 BTU/hr - Main Burners 12,500 BTU/hr - Rear IR Burner Natural Gas and Propane Options
Electrical Requirements	120V/15GFI Electrical Outlet
Grill Type:	Freestanding
Clearance To Combustibles:	Sides: 24" Rear: 24"

