

2

1

B

B

TOP VIEW

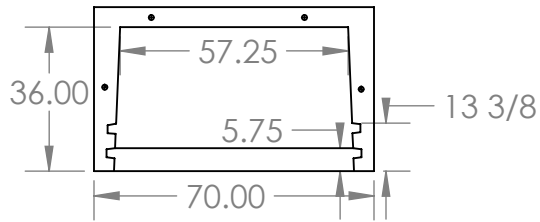

FRONT VIEW

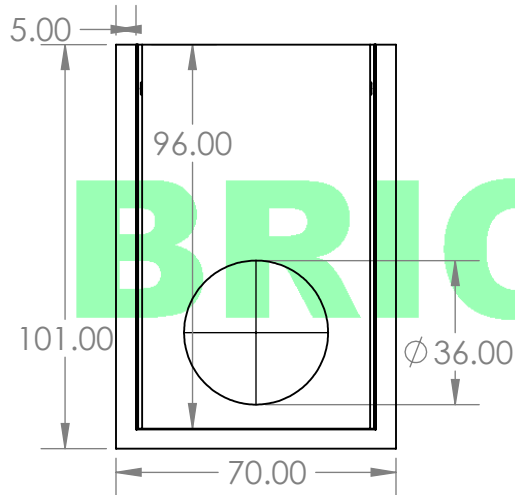

SIDE VIEW

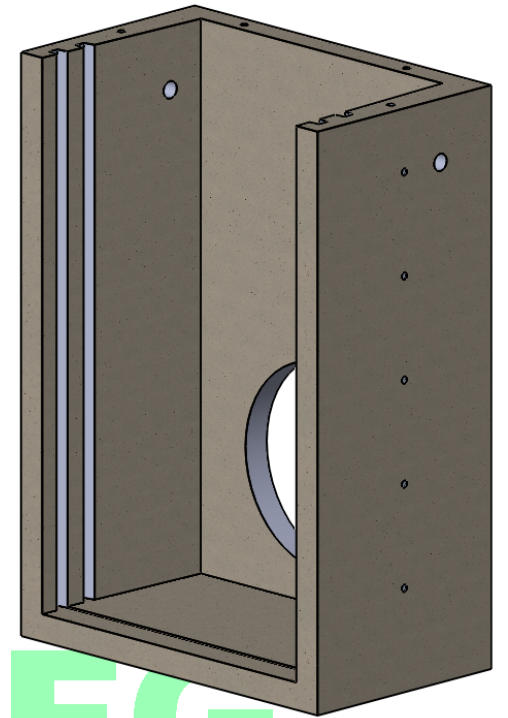
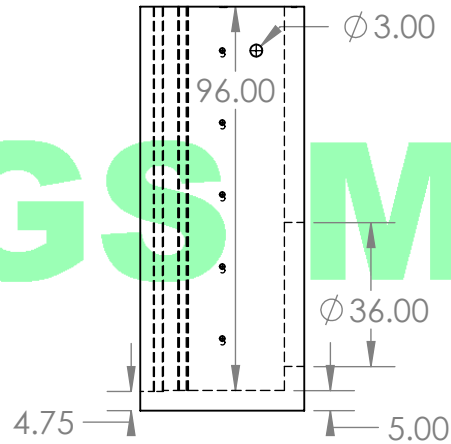

BRIGGS MFG

A

A

PROPRIETARY AND CONFIDENTIAL

THE INFORMATION CONTAINED IN THIS DRAWING IS THE SOLE PROPERTY OF **BRIGGS MFG, INC.** ANY REPRODUCTION IN PART OR AS A WHOLE WITHOUT THE WRITTEN PERMISSION OF **BRIGGS MFG, INC** IS PROHIBITED.

530-934-2663

		UNLESS OTHERWISE SPECIFIED:		NAME	DATE
		DIMENSIONS ARE IN INCHES	DRAWN	JANE F	03022018
		TOLERANCES:	CHECKED		
		FRACTIONAL ±	ENG APPR.		
		ANGULAR: MACH ± BEND ±	MFG APPR.		
		TWO PLACE DECIMAL ±	Q.A.		
		THREE PLACE DECIMAL ±	COMMENTS:		
		INTERPRET GEOMETRIC TOLERANCING PER:			
		MATERIAL			
		FINISH			
NEXT ASSY	USED ON				
APPLICATION		DO NOT SCALE DRAWING			

TITLE:

TWIN TRACK™ WEIR 5X8 36in

SIZE	DWG. NO.	REV
A	TT58	

SCALE: 1:32 WEIGHT: 6800# SHEET 1 OF 1

2

WWW.BRIGGS CONCRETE.COM

1