

B

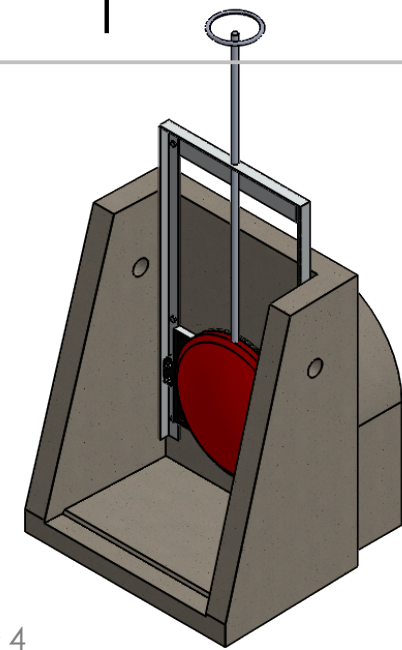
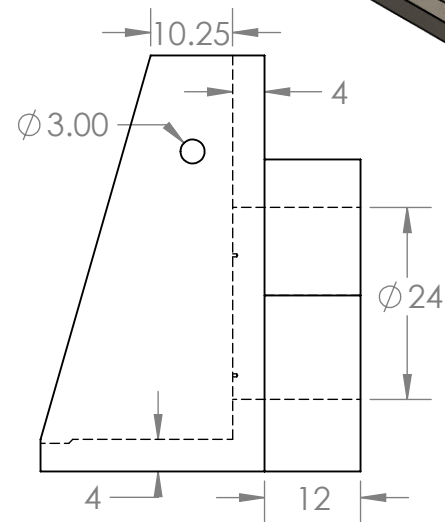
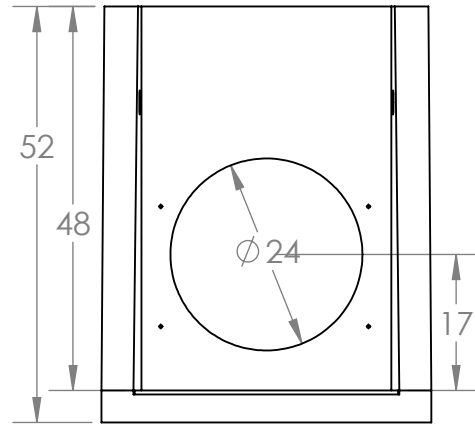
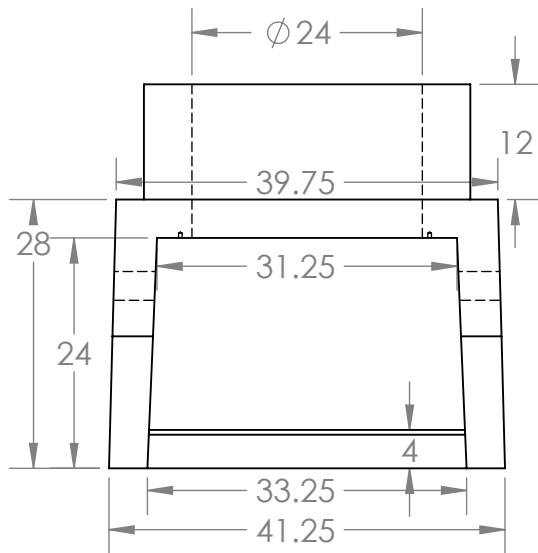

B

A

A

PROPRIETARY AND CONFIDENTIAL
 THE INFORMATION CONTAINED IN THIS DRAWING IS THE SOLE PROPERTY OF BRIGGS MFG, INC. ANY REPRODUCTION IN PART OR AS A WHOLE WITHOUT THE WRITTEN PERMISSION OF BRIGGS MFG, INC. IS PROHIBITED. 530-934-2663

| | | UNLESS OTHERWISE SPECIFIED: | NAME | DATE |
|-------------|---------|--------------------------------------|-----------|----------|
| | | DIMENSIONS ARE IN INCHES | DRAWN | Jane F |
| | | TOLERANCES: | CHECKED | 12/17/18 |
| | | FRACTIONAL \pm | ENG APPR. | |
| | | ANGULAR: MACH \pm BEND \pm | MFG APPR. | |
| | | TWO PLACE DECIMAL \pm | Q.A. | |
| | | THREE PLACE DECIMAL \pm | COMMENTS: | |
| | | INTERPRET GEOMETRIC TOLERANCING PER: | | |
| | | MATERIAL | | |
| NEXT ASSY | USED ON | FINISH | | |
| APPLICATION | | DO NOT SCALE DRAWING | | |

www.briggsconcrete.com

TITLE:

OUTFALL 3'W X 4' H
C-10 24"

| | | |
|----------|-----------|-----|
| SIZE | DWG. NO. | REV |
| A | OF34C1024 | |

| | | |
|-------------|---------|--------------|
| SCALE: 1:48 | WEIGHT: | SHEET 1 OF 1 |
|-------------|---------|--------------|

2

1