

P38+ Circuit Board Upgrade Kit

Part #1-00-7738111 - Pre Serial #008190059



Kit Includes:

- (1) Circuit Board Kit
- (1) Wiring Diagram
- (1) Wiring Harness
- (1) Exhaust Sensing Probe
- (1) Mounting Plate
- (1) Drill Fixture
- (1) Manual
- (1) Misc Parts Pack

Tools Needed

- 5/16" Nut driver
- Crimping Tool
- 1/8" HS Bit (with kit)
- 1/4" or 3/8" HS Bit
- 10 Tie Wraps
- Right & Left Hand Metal Shears (Red & Green Handles)

- Wire Strippers
- Diagonal Cutting Pliers
- Philips Screwdriver
- Small Flat File

Remove rear panels exposing the rear of the unit, Figure 1.

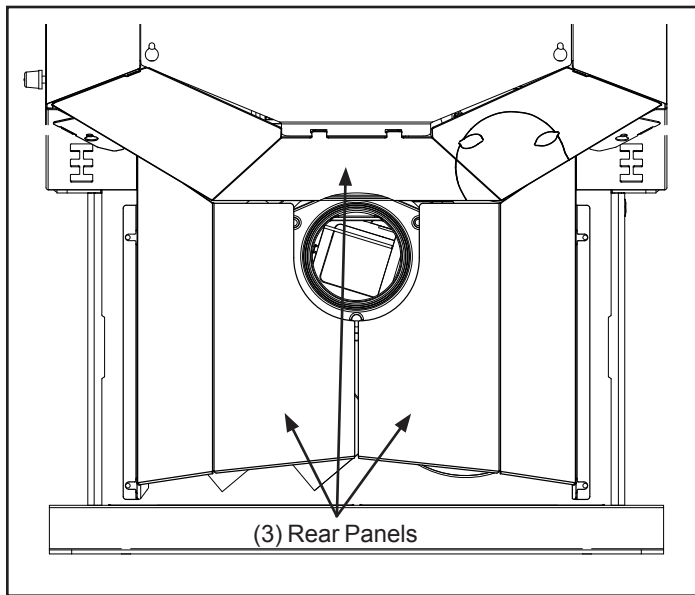

Figure 1 - Remove rear panels.

Remove wiring from circuit board (feed motor, combustion blower, distribution blower, Exhaust Sensing Probe (ESP) and power supply), Figure 2.

NOTE: DO NOT CUT THESE WIRES, These will be re-used when installing the new wiring harness.

Cut wire ties and remove wires from heat shield.

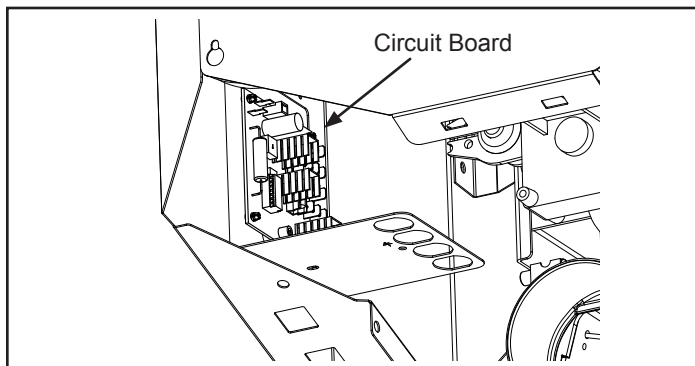

Figure 2 - Remove wiring from circuit board.

Using a philips screwdriver remove the black sheetmetal screws allowing the control board panel to be pulled away from the hopper, Figure 3.

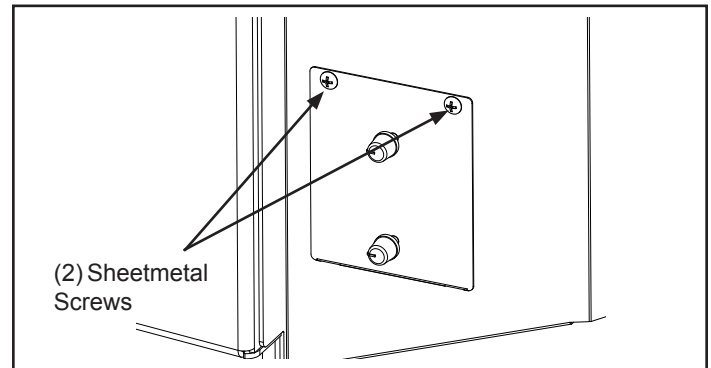

Figure 3 - Remove sheetmetal screws.

Remove cords and cord clamps from the existing circuit board plate and place panel and circuit board to the side as these will no longer be used.

Once the circuit board plate is removed place the template on the hopper as shown in Figure 4.

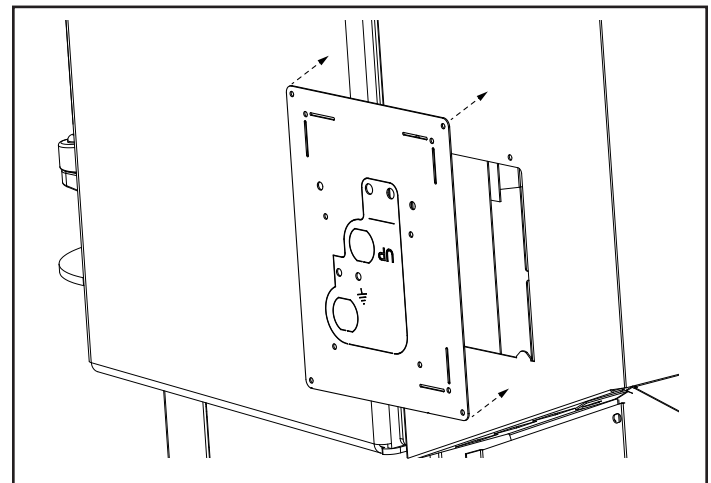

Figure 4

Hold plate in place using the (2) black sheetmetal screws that held the original circuit board plate to the hopper. Figure 5.

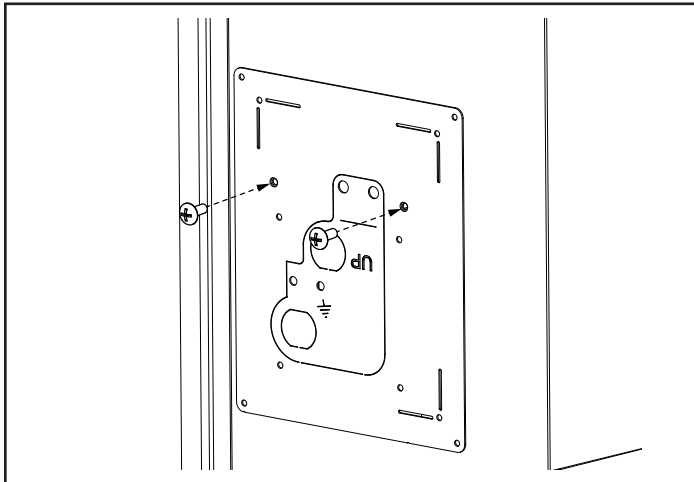

Figure 5

Once the template is mounted, use an awl to scribe the hopper within the slots as shown in Figure 6.

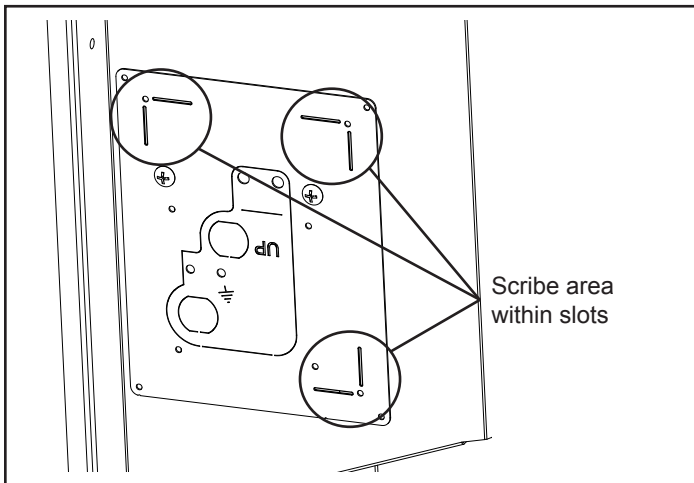

Figure 6 - Scribe slots

Drill (7) pilot holes in hopper using 1/8" drill bit, Figure 7. After holes are drilled, use a square to finish the scribe lines on the hopper between holes.

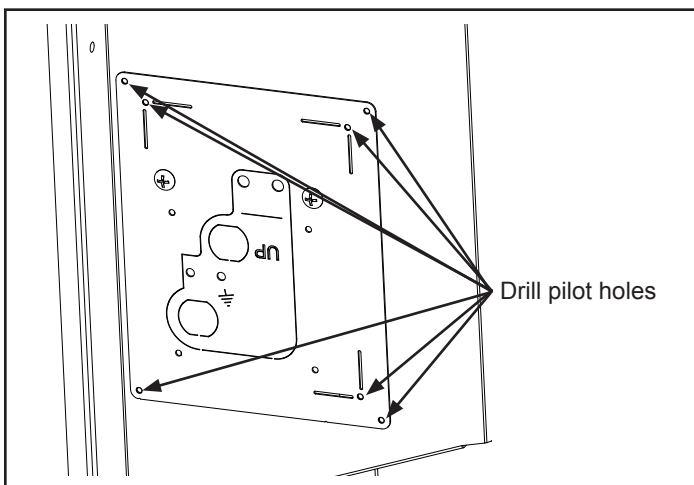

Figure 7

Using right and left handed sheet metal shears, cut on the scribed lines to open the hole to accept the new circuit board and plate, Figure 8. Once complete, use a flat file to remove any burrs created from cutting the sheetmetal.

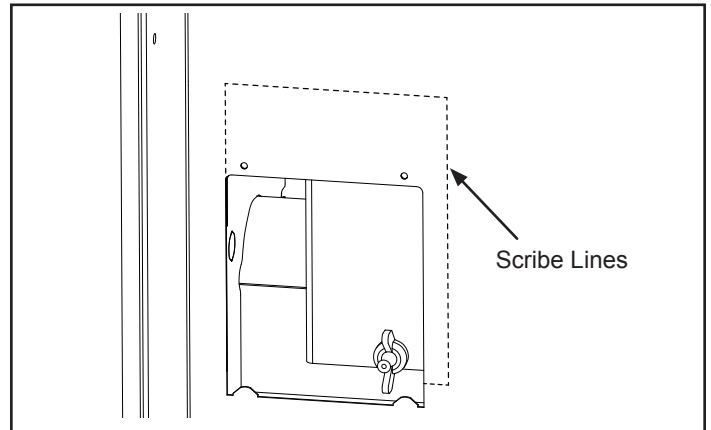

Figure 8

Install new circuit board plate using the 4 black sheetmetal screws supplied in the kit, Figure 9.

Note: Control board dip switch settings are preset with dipswitch #5 turned on. Prior to installing circuit board, insure this setting is correct to the color ESP being installed.

Red ESP wire = Dipswitch #5 must be turned to the "ON" position.

Black ESP wire = Dipswitch #5 must be turned to the "OFF" position.

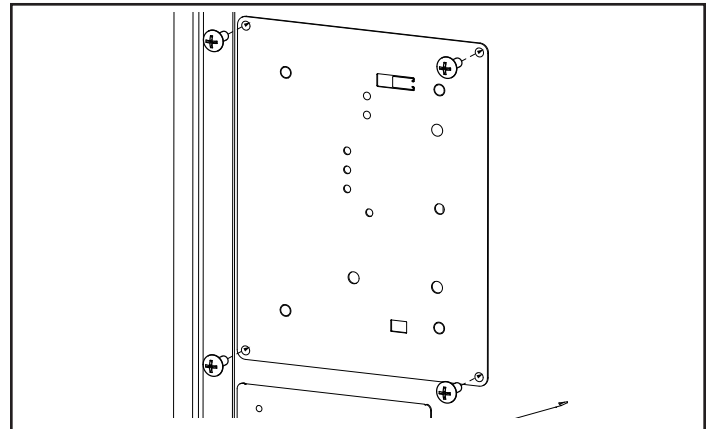

Figure 9 - Install (4) sheet metal screws

Bend the tab flat located on the heat shield above the distribution blower, Figure 10.

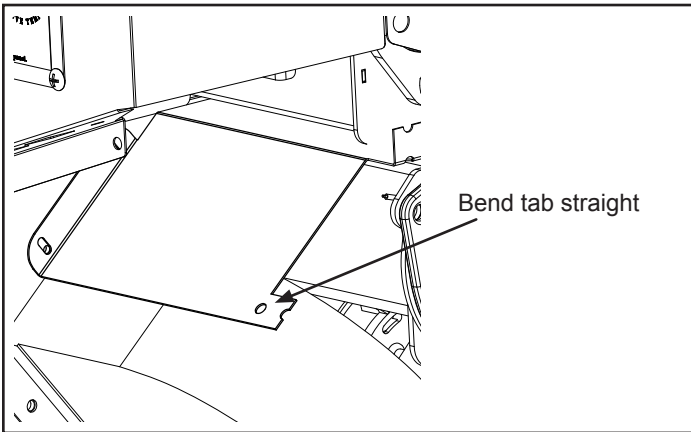

Figure 10

Remove the cord clamp plate from template, Figure 11.

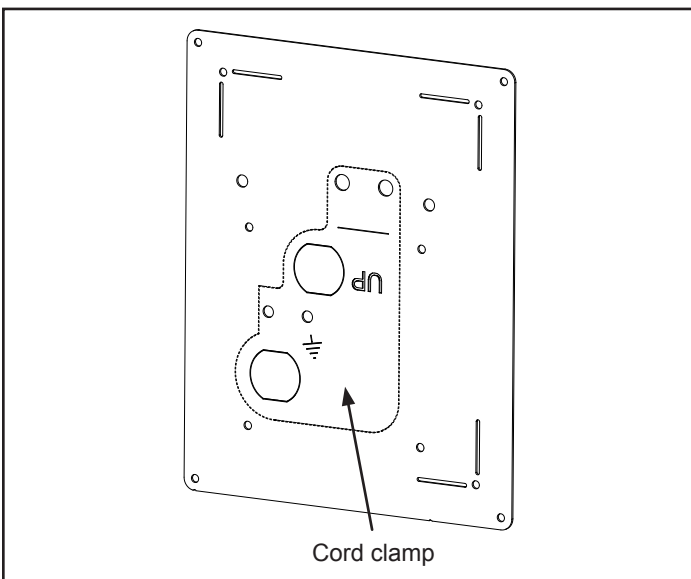

Figure 11

Install power cord and distribution blower cord in the cord clamp plate, Figure 12.

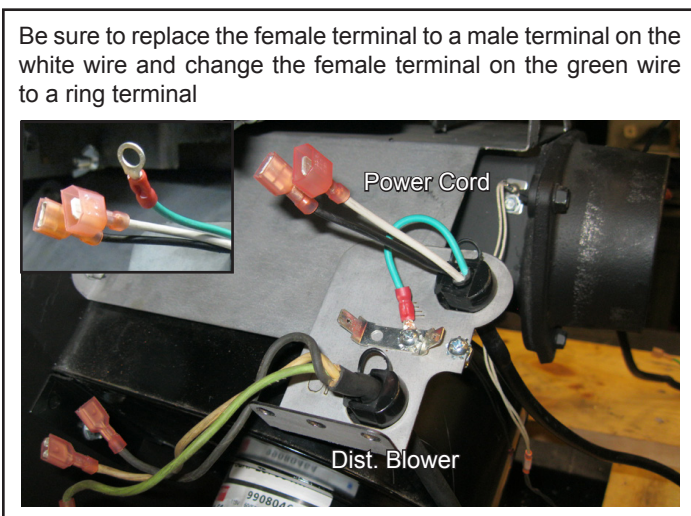

Figure 12

Install power cord clamp plate on heat shield using the grounding post supplied, Figure 13.

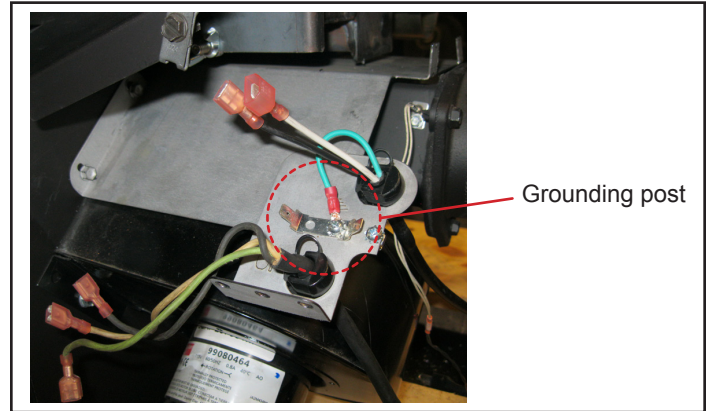

Figure 13

Tie wrap wires to the cord clamp and tie wrap wires to the heat shield. Figure 14.

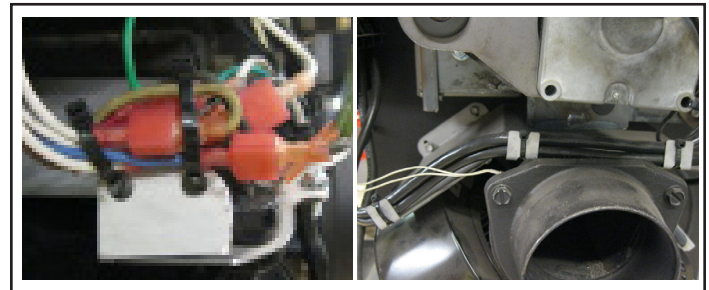

Figure 14

Now wire the remaining motors and blowers in accordance to the wiring diagram supplied. The sky blue jumper is used between the feed motor and the pressure switch if necessary.

Install Exhaust Sensing Probe (ESP) supplied in the kit.

Note: If the unit has a thermostat installed onto the circuit board, you must remove the thermostat and install the room sensing probe if "room temp" is going to be used.