

# Oakleaf Combustion Package Replacement Instructions

## Part # 1-00-797022

# HARMAN®

BUILT TO A STANDARD, NOT A PRICE

### Contents of Kit;

- (1) 3-40-797022 - Combustion Package with Gasket
- (1) 2-00-797504 - Combustion Package Cap
- (2) 3-30-1252005014 - 1/4-20 x 1/2" HCS
- (2) 3-30-1311820013 - 5/16-18 x 2" HCS
- (2) 3-30-3025202509 - 1/4-20 x 2-1/2" SS SHCS
- (2) 3-30-80311813 - 5/16-18 FHN
- (2') 3-44-10050 - 1-1/2" x 3/8" Bulb Gasket w/PSA
- (10') 3-44-1312 - 1/4" Round Gasket w/PSA

The following are instruction on how to properly replace the **Oakleaf** combustion package. **Note:** The combustion package must be removed from the front of the unit.

1. Remove (2) front upper brick clips located at each front corner of the firebox and remove side bricks. Figure 1.

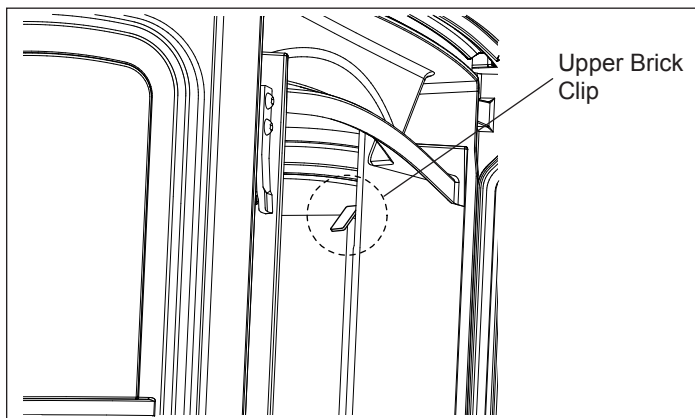

Figure 1

2. Remove the (2) andirons along with (2) rear brick clips located at the top corners of the center brick. Figure 2.

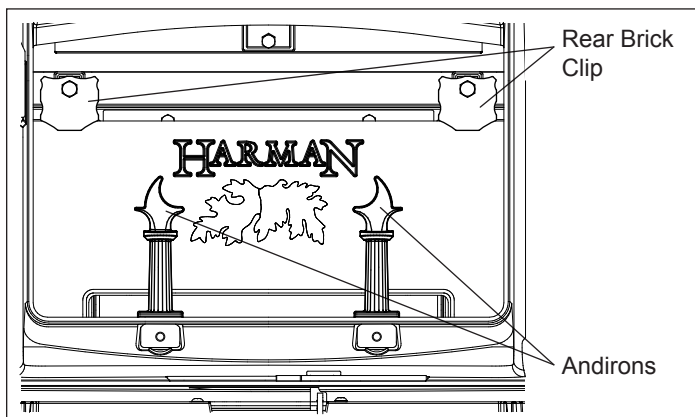

Figure 2

3. Remove the decorative center brick. Figure 3.

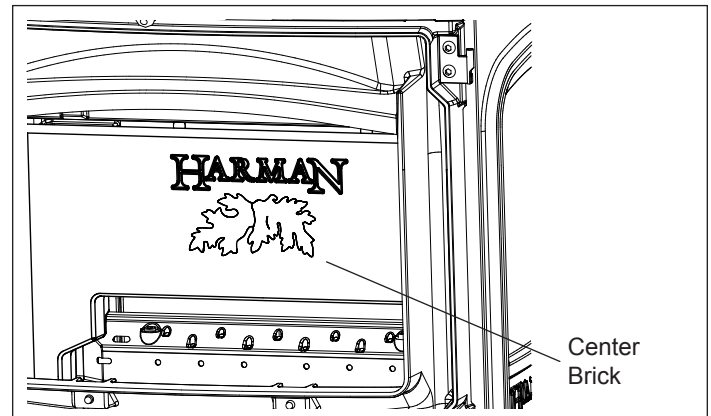

Figure 3

4. Remove (2) 1/4"-20 x 3" cap screws and remove the shoe brick. Figure 4.

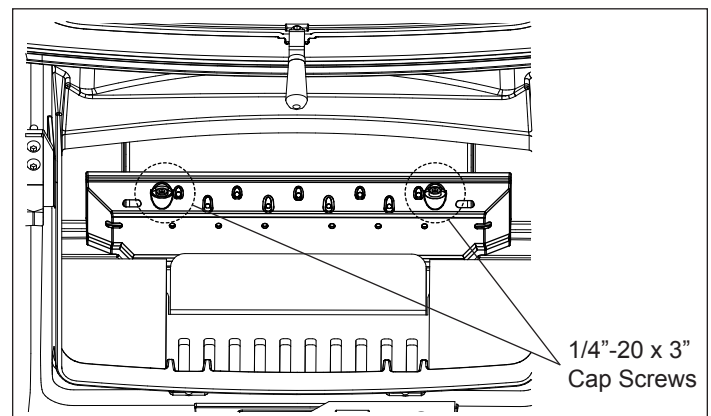

Figure 4

5. Remove (2) 1/4"-20 x 1/2" bolts and remove the center seal plate. Figure 5.

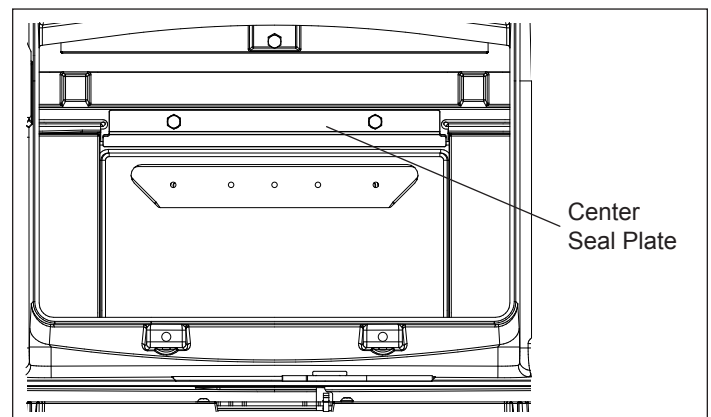

Figure 5

6. To remove the left and right seal plates you must first remove the lower rear heat shield. Once the heat shield is removed, you'll need to use a wrench or socket to hold the bolt in place while you loosen and remove the 5/16" nuts from inside the firebox. Do this for both sides. Figure 6.

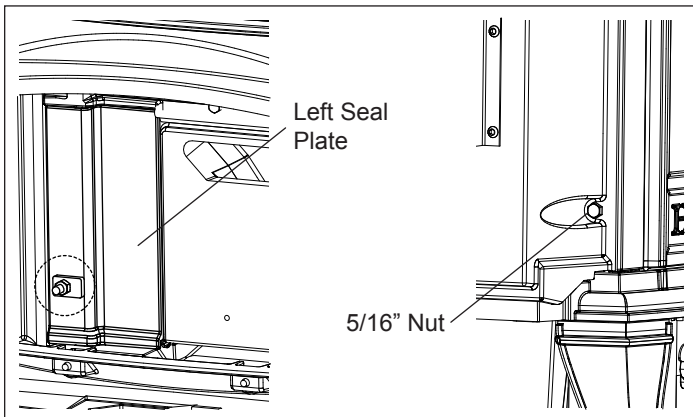

Figure 6

7. Once seal plates are removed slowly pull forward on the combustion package and remove it from the firebox. Figure 7. **Note: There is a metal cap located on top of the combustion package that should come out along with the package.**

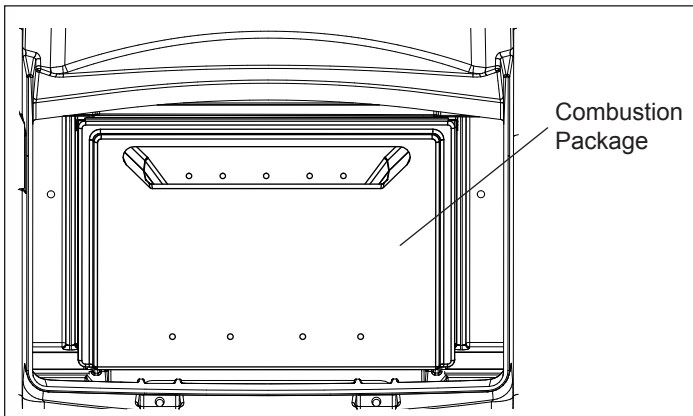

Figure 7

8. The new combustion package should have come with a new combustion package cap, take new combustion package and place the cap on top of it prior to installing combustion package. Figure 8.

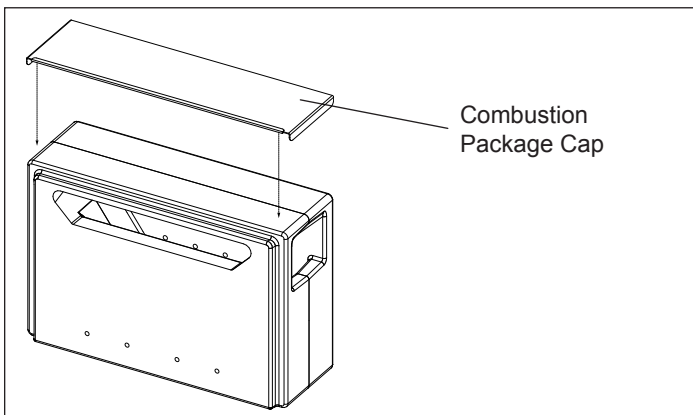

Figure 8

Prior to re-installing the new parts into your unit be sure to replace the gaskets on the following parts.

Replace the 1/4" round gasket on both the right and left seal plate prior to re-installing. Figure 9.

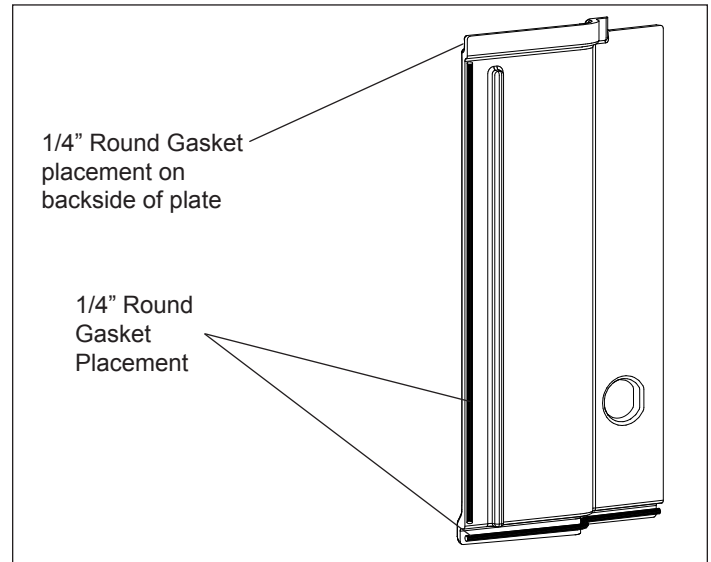

Figure 9

Replace the 1/4" round gasket located on the Shoe Brick as shown. Figure 10.

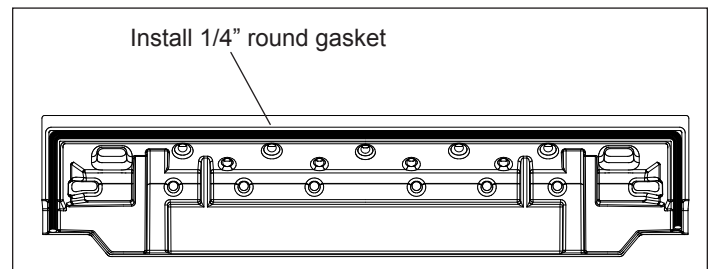

Figure 10

Replace the Tadpole gasket located on the Center Seal Plate as shown. Figure 11.

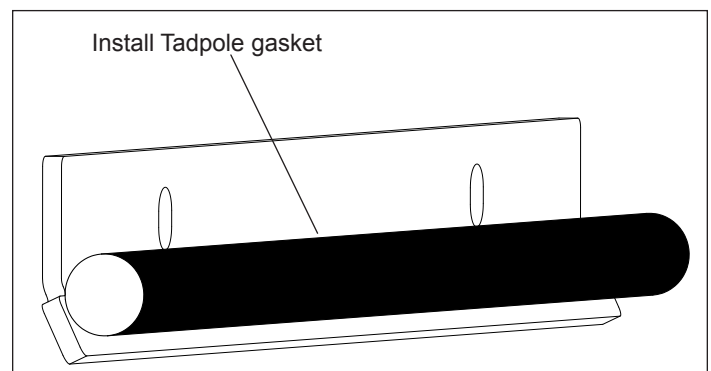

Figure 11

Reinstallation is the reverse of removal. After the combustion package is in the unit, the center seal plate, left and right seal plates and shoe brick should be replaced, respectively. The refractory, heat shields and andirons can be reinstalled in any order.