

QUADRA-FIRE®

FEED MOTOR REPLACEMENT & BEARING ADJUSTMENT

CB1200 Insert, Contour, Castile Series and Santa Fe Series, Part 812-4421

CB1200 Stove Only: Feed Assembly Replacement, Part 812-3690

Included In Kit: Feed Motor and Motor Mount

Tools Required: #2 Phillips Screwdriver, 7/16" wrench and 5/32" Allen wrench

NOTE: Wiring configurations on page 4.
Feed Motor Bearing Adjustments on page 5.

CB1200 Pellet Stove

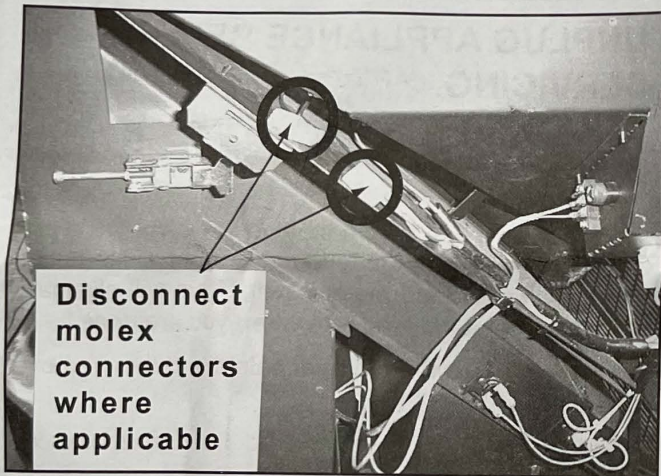

Figure 1

1. Open right side curtain and remove hopper side heat shield to access wiring and disconnect molex wire connections. **Figure 2.** If there is not any molex connectors then disconnect spade connectors under feed motor cover.
2. Either lift up and support the stove's top while you work or remove it from the stove by loosening the 5 screws that attach the hinge to the hopper.
3. Mark the feed adjustment rod position on feed motor cover for future reference. This will eliminate the need to re-set the feed rate when you are done. Remove cover and front access plate from hopper. Use 7/16" wrench to remove the two nuts holding down the nylon bearing and motor mount. **Figure 2.**
4. Remove feed motor/auger assembly by pulling out towards face of stove.



CAUTION

UNPLUG APPLIANCE BEFORE SERVICING.

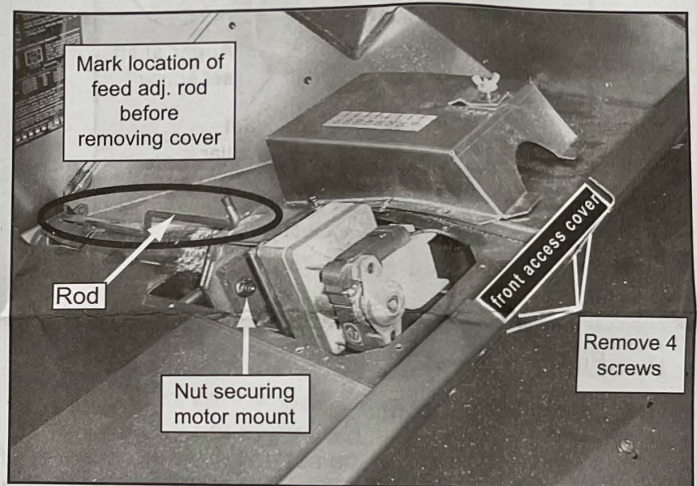
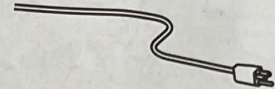

Figure 2

Replacing Feed Motor Assembly Only:

Replace feed assembly and stop here. Re-assemble feed assembly by reversing steps 2-4.

Determine Type of Motor Mount:

If you have an older mount, replace with new one supplied. **Figure 3.** Skip to Step 6.

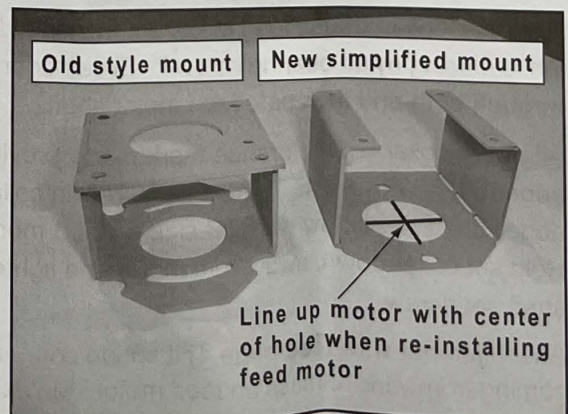

Figure 3

HEARTH & HOME
technologies

1445 North Highway
Colville, WA 99114

250-6660F October 11, 2010 Page 1 of 4

www.quadrafire.com

5. New Simplified Mount

- Loosen set screw that secures auger shaft to feed motor shaft. **Figure 4.**
- Remove 4 screws attaching feed motor to mount. Lift off old motor and replace with new. Secure with screws.
- Ensure auger shaft set screw aligns with flat side of feed motor shaft and tighten. Skip to Step 6e below.

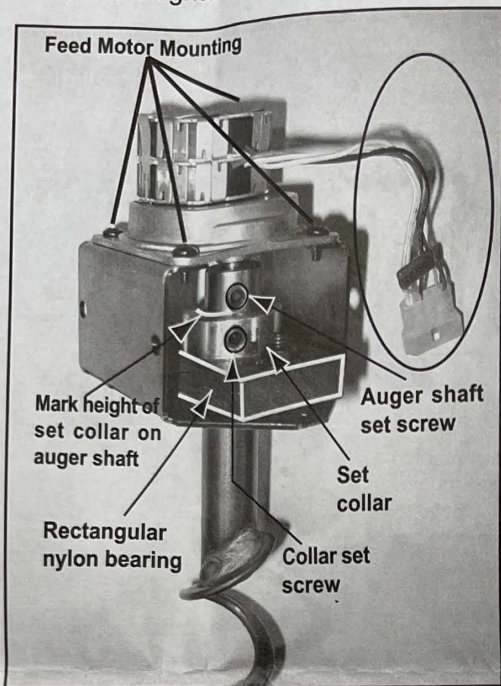

Figure 4

6. Replacing Old Mount

- First mark the height of the set collar on the auger shaft with a black marker for future reference. **Figure 4.** **Remove** set screw securing auger shaft to feed motor shaft. Only **loosen** set screw in set collar and ensure collar will slide on shaft.
- Take care not to drop set collar or nylon bearing as you pull auger from the assembly. Set new motor on mount so shaft lines up with center of bottom hole in mount. **Figure 3, page 1.** Re-secure with screws.
- Place set collar around feed motor shaft and hold in place while placing nylon bearing below it. Slide auger shaft up through both and then onto feed motor shaft.
- Align set collar with reference mark made previously on auger shaft. **Figure 4.** Tighten set screw in collar. Align auger shaft set screw with flat side of feed motor shaft. Hold set collar down, away from motor and tighten auger shaft set screw.
- Attach jumper wire (**see page 4**) if spade connectors are coming from wire harness on feed motor. Molex connector does not require a jumper. **Figure 4.**
- Re-install auger assembly by reversing Steps 2 through 4.

1200-I Pellet Insert

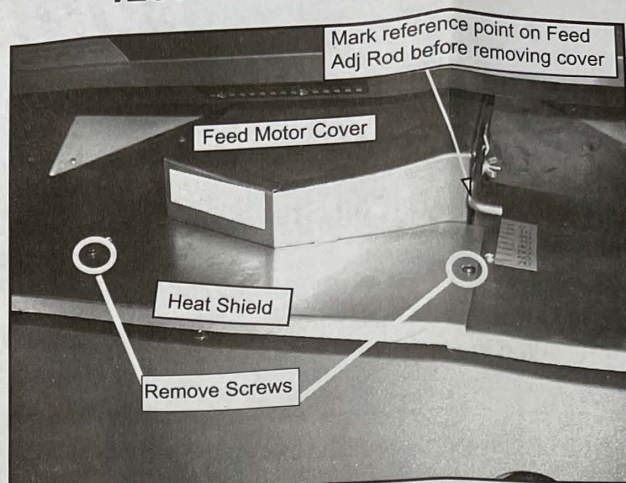
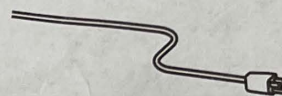

Figure 5



CAUTION

UNPLUG APPLIANCE BEFORE SERVICING.



- Open hopper lid. Before starting to disassemble place a reference mark on the feed adjustment rod in relation to its position on feed motor cover. This will eliminate the need to re-set the feed rate when you are done.
- Remove 2 screws from heat shield and then remove the heat shield.
- Slide feed motor cover toward front of appliance and remove.
- Disconnect the spade or molex Connectors.
- Follow Step 5 (**New Simplified Mount**) to replace Feed Motor.
- Attach Molex or spade connectors to the feed motor wire harness, using jumper if needed. **Figure 4.**
- Re-assemble in reverse order.

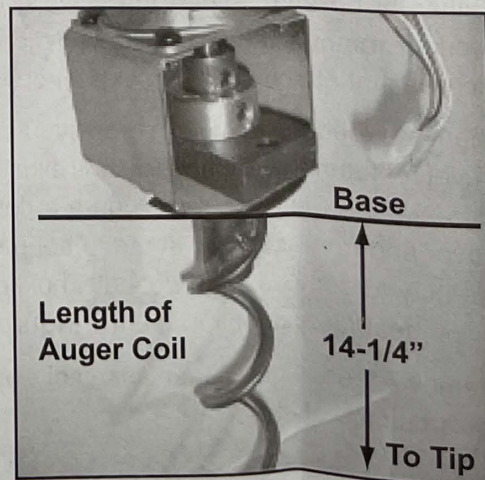

Figure 6

Contour, Castile, Castile Insert, Santa Fe and Santa Fe Insert

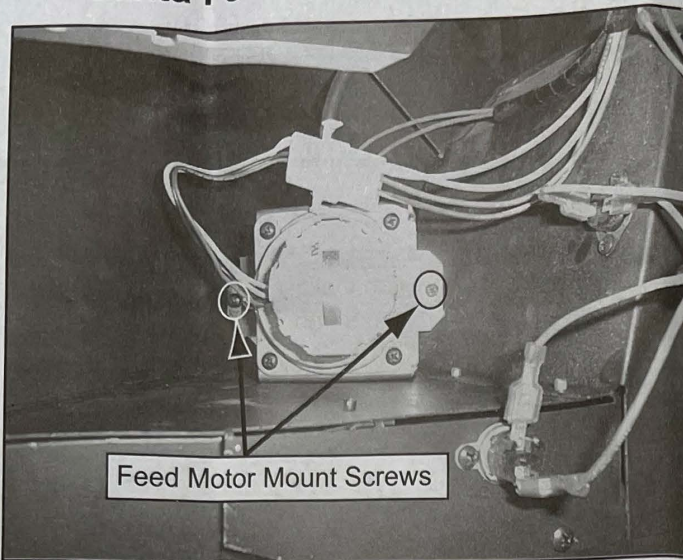

Figure 7



CAUTION

UNPLUG APPLIANCE BEFORE SERVICING.



1. Open the right side curtain to expose the feed motor.
NOTE: Castile Insert and Santa Fe Insert requires **removal** of right side panel.
2. Disconnect the molex or spade connectors. Remove the 2 screws from the feed motor mount. **Figure 7.**

Contour/Castile Insert/Santa Fe and Santa Fe Insert

Pull the feed motor/auger assembly straight out towards you, being careful not to hit the control box.

Castile only

First remove the control box. As you pull the feed motor/auger assembly toward you, turn counter-clockwise to twist the auger coil out of the tube and around the cast stove side.

3. Follow Step 5 (New Simplified Mount) on page 2 to replace feed motor.
4. Re-assemble in reverse order

Wire Harness Jumper Assembly

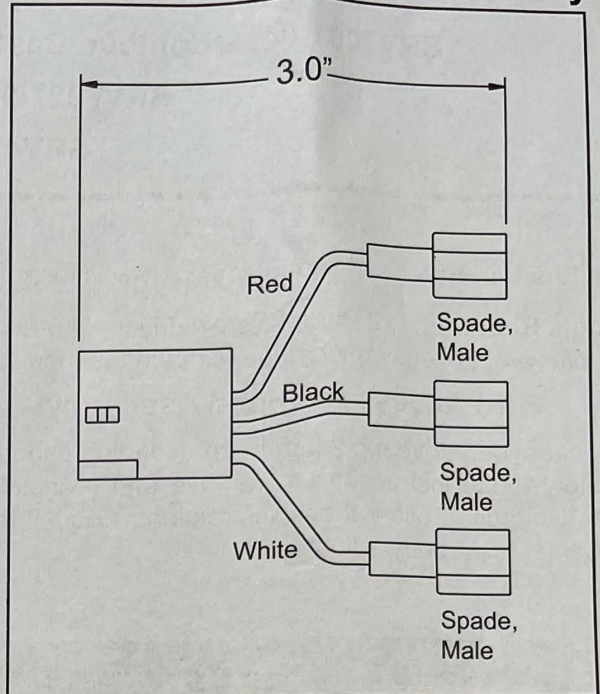

Figure 8

1. If the appliance has a junction box with spade connectors, use the jumper assembly.
2. If installing a new feed motor in an appliance with molex connectors coming from the junction box, no jumper is needed.

Pellet Feed Motor Bearing Adjustment Instructions

SRV7001-046 - Contour, Castile, Santa Fe Stove & Insert & Mt. Vernon

SRV7027-024 - 1200 Stove & Insert

SRV414-5540 - Castile Insert

Included in Kit: Feed spring assembly & teflon gasket

Tools Required: #2 Phillips screw driver, 7/16" wrench and/or 5/32" Allen wrench depending on the model.

To Access the Feed Assembly

Locate your stove model on the preceding pages and follow those instructions to remove and re-install the feed motor. Follow these instructions to confirm the bearing is properly adjusted.

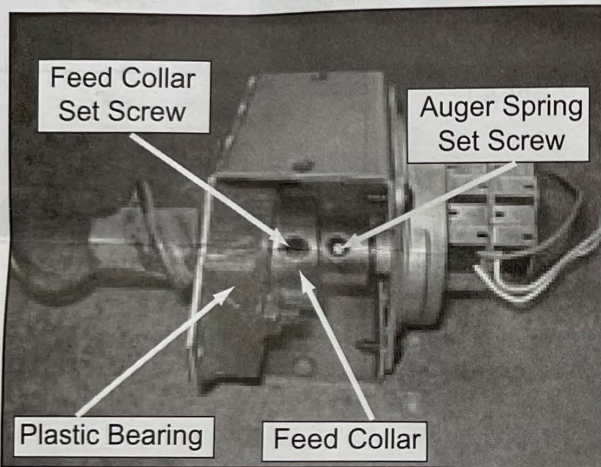

Figure 9

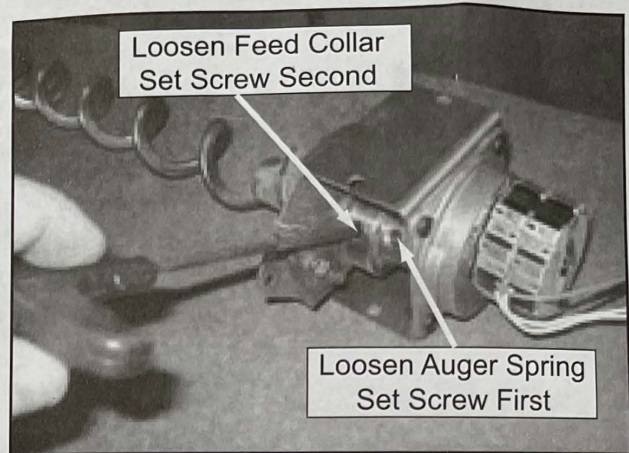

Figure 10

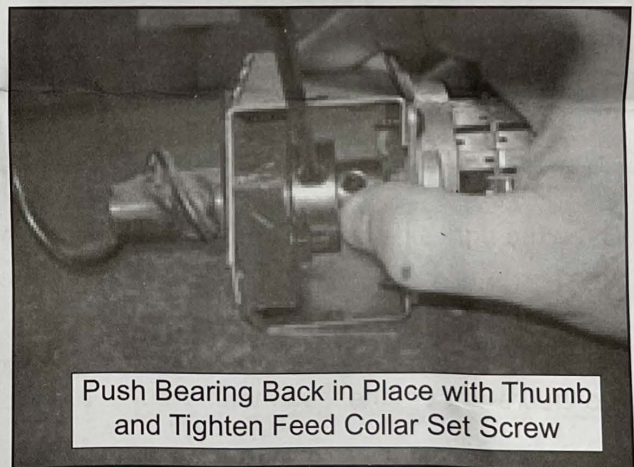

Figure 11

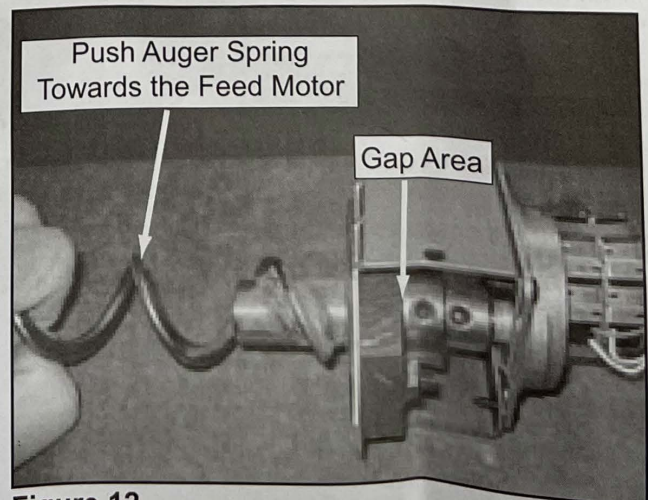

Figure 12

1. Using a Phillips head screw driver loosen the auger spring set screw first and then the feed collar set screw and remove the auger spring. **Figure 10.**
2. Insert the new auger spring and tighten the auger spring set screw.
3. Move the feed collar away from the plastic bearing to release the pressure and then push it lightly against it again. **Figure 11.**
4. Tighten the feed collar set screw.
5. Push the auger spring towards the feed motor. The gap between the collar and plastic bearing should be just under a dime's width. **Figure 12.**
6. Discard the rubber gasket between the feed assembly and the drop tube and replace with the teflon gasket.