

## BUELL® LIGHTNING® XB REMOVABLE TRUNK BAG

### General

The Buell Lightning Removable Trunk Bag is designed to fit 2003 and later Buell XB9S, XB9SX, XB12S and XB12Scg model motorcycles.

Installation of the trunk bag will require Buell Lightning XB Removable Saddlebags (Kit No. 91458-05Y).

There are no service parts for this kit.

#### NOTE

A Service Manual for the year and model motorcycle is available at any Buell dealer.

### Install the Saddlebags

Follow the instructions found in the saddlebag kit (Kit No. 91458-05Y) to install the saddlebags.

### Using the Trunk Bag

See Figure 1. Adjust the shoulder strap by sliding the D-ring (1) up or down and then slide the shoulder pad into position.

During use, the hold down straps can be folded back to store the quick release latches (2) in the elastic pockets (3).

See Figure 2. To expand the trunk bag, unzip the single pulls on the ends of the bag.

### Attach the Trunk Bag

#### ⚠ WARNING

Improper loading of cargo or installation of accessories can affect motorcycle stability and handling, which could result in death or serious injury. (00099a)

- Maximum recommended load is 7 lbs (3.1 Kg) total for the trunk bag alone.
- Remove and store the shoulder strap inside the trunk bag.
  1. Run double pulls together to close side pouch/opening and zip the end compartments closed.
  2. Bottom toward rider, snap the two quick release latches on each side of the trunk bag into the front and rear catches on the saddlebags.
  3. Pull the latch straps to secure the trunk bag.

### Rain Cover

Compress the spring loaded stop and pull the draw string tight to close the rain cover over the trunk bag. Release the stop to secure the cover.

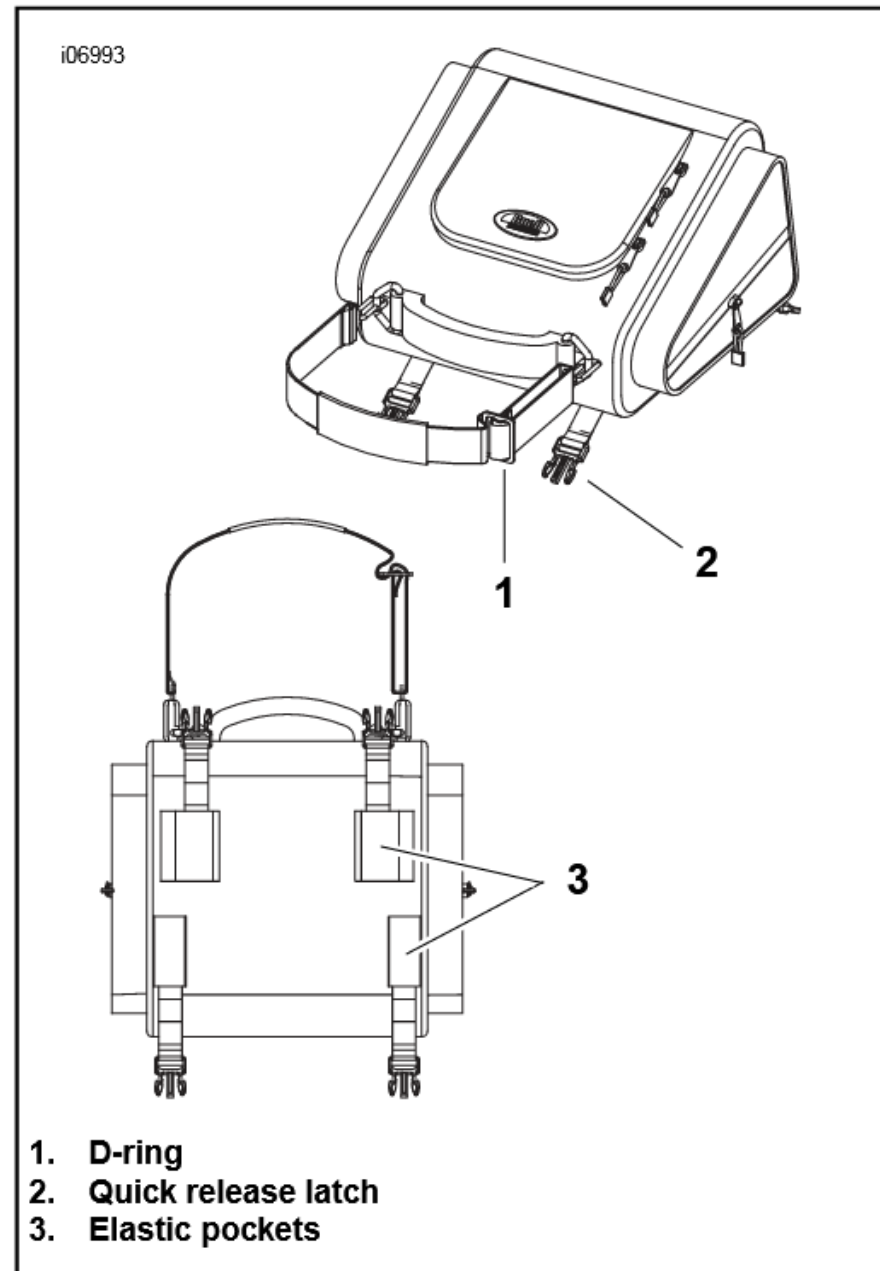

Figure 1. Trunk Bag - Elastic Pockets

