



CMI Lite

CMI (Control Module Interface) Lite is a hand-held service tool for EFI-equipped Buell™ motorcycles. This tool allows the user to read ECM historic trouble codes, clear historic codes, check the idle position, and reset the Throttle Position Sensor. The tool uses the standard diagnostic port to communicate with the ECM.



Table 1: The Status LEDs indicate power, communication, and calibration status.

LED	On	Flashing
Red	Searching for ECM connection	Communicating with ECM
Yellow	Error or engine rotation	Status of requested function
Green	Completed requested function	Status of requested function

Table 2: Interface cable

4-way Deutsch pin	Wire color	Usage
1	White	Serial TXD (Transmit Data)
2	Black	Ground
3	Green	Serial RXD (Receive Data)
4	Red	12 VDC power (10 mA avg)



Directions for use with DDFI, DDFI-2B, DDFI-2C

Table 3: Diagnostic connector location, motorcycles with DDFI, DDFI-2B, DDFI-2C

Motorcycle	Model Year	Diagnostic connector location
Buell™ X1	1999-2002	Right of the steering head tube
Buell™ S3 and S3T	1999-2002	Under the seat
Buell™ XB9R and XB12R	2003-2007	Left stalk of the fairing support bracket
Buell™ XB9S, XB9SL, XB9Sx, XB12S, XB12Scg, and XB12SS	2003-2007	Under the seat
Buell™ XB12X	2006-2007	Left side of the tail section near rider's leg

Plug the tool into the 4-pin diagnostic connector on the motorcycle.

1. Reading historic trouble codes

The tool causes the ECM to “flash out” trouble codes on the Check Engine Lamp on the instrument cluster.

- a. Begin with the ignition key OFF, run/stop switch in RUN position, and throttle CLOSED.
- b. Turn the ignition key ON. All three LEDs will blink once, and then the red LED will blink continuously. The green and yellow LEDs will indicate the idle setscrew position (see next page).
- c. After at least one second, fully open and hold the throttle for one second. The green LED will blink once. The red LED will continue blinking.
- d. Release the throttle and allow it to fully close. The yellow LED will blink once. The red LED will continue blinking.
- e. Turn the ignition key OFF. All LEDs will turn off.
- f. Turn the ignition key ON. All three LEDs blink once, then the green and red LEDs turn on and stay on.
- g. Read the trouble codes by watching the Check Engine Lamp on the instrument cluster. For a description of how to read the “flash out” sequence and a list of codes see Appendix A.
- h. When done reading codes, turn the ignition key OFF. All LEDs will turn off.



2. Clearing historic trouble codes and resetting the Learned Fuel (Adaptive Fuel) Value

The tool can clear historic trouble codes on all EFI-equipped Buell™ motorcycles. It can also set the Learned Fuel Value to factory default (i.e. 100%).

NOTE 1: If your vehicle is located at high altitudes (e.g. 4000' or more), resetting the Learned Fuel Value to factory default will cause the engine to operate with a rich air/fuel mixture until the ECM self-corrects.

NOTE 2: The historic trouble codes will be cleared prior to resetting the Learned Fuel Value. Please make note of any historic trouble codes prior to resetting the Learned Fuel Value.

- a. Begin with the ignition key OFF, run/stop switch in RUN position, and throttle held OPEN.
- b. Turn the ignition key ON. All three LEDs will blink once, and then the red LED will blink continuously.
- c. Continue to hold the throttle fully OPEN. The yellow LED will blink 4 times, then the green LED will turn on and stay on for one second (see *NOTE below). This indicates that the codes have been cleared. If you DO NOT want to reset the Learned Fuel Value to factory default, CLOSE the throttle at this point and go to step “e.”
- d. If you want to reset the Learned Fuel Value to factory default, continue to hold the throttle fully OPEN. The yellow LED will again blink 4 times, then the green LED and the red LED will turn on and stay on (see *NOTE below). This indicates that the Learned Fuel Value has been set to factory default.
- e. Turn the ignition key OFF. All LEDs will turn off.

*NOTE: If the yellow LED turns on and stays on in steps “c” or “d”, turn the ignition key OFF and retry the procedure. This can happen if:

- The engine is cranked or started
- Communication problems prevent the trouble codes from being cleared or the Learned Fuel Value from being reset to factory default.



Directions for use with DDFI, DDFI-2B, DDFI-2C, continued

3. Checking and adjusting the Idle Setscrew Position

Buell™ motorcycles built prior to model year 2008 have an idle setscrew. This setscrew allows the rider to adjust the engine idle speed. The tool indicates if the idle setscrew is adjusted within normal tolerances.

- a. Begin with the ignition key OFF, run/stop switch in RUN position, and throttle held OPEN.
- b. Turn the ignition key ON. All three LEDs will blink once, then the red LED will blink continuously. The green and yellow LEDs will indicate the idle setscrew position (see Table 1 below).
- c. Adjust the idle setscrew until the Green LED turns on continuously. If the yellow LED is flashing, turn the setscrew IN (opening the throttle plate). If the green LED is flashing, turn the setscrew OUT (closing the throttle plate).

Note: This procedure sets the idle setscrew to factory default setting for typical, near-sea-level locations. Your vehicle may require a higher or lower setpoint depending on engine condition, altitude, and other factors. You may need to adjust the idle setscrew based on actual engine idle RPM. The engine idle speed should be 1050 RPM when warmed up.

Table 4: Idle Setscrew Position Indication

Idle setscrew position	Green LED	Yellow LED
Normal	On (not flashing)	Off
Higher than normal	Flashing (4 times per second)	Off
Lower than normal	Off	Flashing (4 times per second)



Directions for use with DDFI, DDFI-2B, DDFI-2C, concluded

4. Resetting the TPS zero position

The tool can reset the TPS zero position on all EFI-equipped Buell™ motorcycles. However, all Model Year 2008 and later EFI-equipped Buell™ motorcycles maintain the TPS zero position automatically, so using the tool is usually not necessary.

For all EFI-equipped Buell™ motorcycles prior to model year 2008, the adjustable idle screw must be backed out such that the throttle plate fully closes in the throttle bore. This must be done before using the following procedure. For model year 2008 and later, the idle screw is factory adjusted and should not be changed.

- a. Begin with the ignition key OFF, run/stop switch in RUN position, and throttle CLOSED.
- b. Turn the ignition key ON. All three LEDs will blink once, and then the red LED will blink continuously. The green and yellow LEDs will indicate the idle setscrew position (see 3. Checking and adjusting the Idle Setscrew Position).

Note: The yellow light should blink continuously, indicating that the throttle position is too low (since the throttle plate has been fully closed at the start of this procedure). It may indicate otherwise if the TPS zero position is off significantly.

- c. After at least one second, hold the throttle fully OPEN for one second. The green LED will blink once. The red LED will continue blinking.
- d. Release the throttle and allow it to fully CLOSE. The yellow LED will blink once. The red LED will continue blinking.
- e. After at least one second, hold the throttle fully OPEN for one second. The green LED will blink once. The red LED will continue blinking.
- f. Release the throttle and allow it to fully CLOSE. The yellow LED will blink twice. The red LED will continue blinking.
- g. After at least one second, hold the throttle fully OPEN for one second. The green LED will blink once. The red LED will continue blinking.
- h. Release the throttle and allow it to fully CLOSE. The red LED will turn on continuously, and the yellow LED will blink three times. Then, the green LED will turn on for three seconds, indicating that the zero position has been set (see *NOTE below). Then, the red and yellow LEDs will flash continuously.
- i. Turn in the throttle setscrew until the green LED turns on, indicating a factory default idle position.
- j. Turn off the ignition. All LEDs will turn off.

*NOTE: If the yellow LED turns on and stays on during step h, turn the ignition key OFF, fully CLOSE the throttle plates, and retry the procedure. This can happen if:

- The engine is cranked or started
- Communication problems prevent the TPS from being reset
- The throttle is not fully closed in step h



Directions for use with DDFI-3

Table 5: Diagnostic connector location, motorcycles with DDFI-3

Motorcycle	Model Year	Diagnostic connector location
Buell™ XB9R and XB12R	2008-2010	Left stalk of the fairing support bracket
Buell™ XB9S, XB9Sx, XB12S, XB12Scg, and XB12SS	2008-2010	Under the seat
Buell XB12X, XB12X, XB12XP	2008-2010	Left side of the tail section near the rider's leg
Buell™ 1125R and 1125CR	2008-2010	Below left air scoop

Plug the tool into the 4-pin diagnostic connector on the motorcycle.

1. Reading historic trouble codes

The tool causes the ECM to “flash out” trouble codes on the Check Engine Lamp on the instrument cluster. This function works on all motorcycles listed except for the Buell™ 1125, which provides trouble code information through the text display on the instrument cluster.

- a. Begin with the ignition key OFF, run/stop switch in RUN position, and throttle CLOSED.
- b. Turn the ignition key ON. All three LEDs will blink once, and then the red LED will blink continuously.
- c. After at least one second, hold the throttle OPEN for one second. The green LED will blink once. The red LED will continue blinking.
- d. Release the throttle and allow it to fully close. The yellow LED will blink once. The red LED will continue blinking.
- e. Turn the ignition key OFF. All LEDs will turn off.
- f. Turn the ignition key ON. All three LEDs blink once, then the green and red LEDs turn on and stay on.
- g. Read the trouble codes by watching the Check Engine Lamp on the instrument cluster. For a description of how to read the “flash out” sequence and a list of codes see Appendix A.
- h. When done reading codes, turn the ignition key OFF. All LEDs will turn off.



2. Clearing historic trouble codes and resetting the Learned Fuel (Adaptive Fuel) Values

The tool can clear historic trouble codes on all EFI-equipped Buell™ motorcycles. It can also set the Learned Fuel Values to factory default.

NOTE 1: If your vehicle is located at high altitudes (e.g. 4000' or more), resetting the Learned Fuel values to factory default will cause the engine to operate with a rich air/fuel mixture until the ECM self-corrects.

NOTE 2: The historic trouble codes will be cleared prior to resetting the Learned Fuel Values. Please make note of any historic trouble codes prior to resetting the Learned Fuel Values.

- a. Begin with the ignition key OFF, run/stop switch in RUN position, and throttle held OPEN.
- b. Turn the ignition key ON. All three LEDs will blink once, and then the red LED will blink continuously.
- c. Continue to hold the throttle fully OPEN. The yellow LED will blink 4 times, then the green LED will turn on and stay on for one second (see *NOTE below). This indicates that the codes have been cleared. If you DO NOT want to reset the Learned Fuel Values to factory default, CLOSE the throttle at this point and go to step “e.”
- d. If you want to reset the Learned Fuel Values to factory default, continue to hold the throttle fully OPEN. The yellow LED will again blink 4 times, then the green LED and the red LED will turn on and stay on (see *NOTE below). This indicates that the Learned Fuel Values have been set to factory default.
- e. Turn the ignition key OFF. All LEDs will turn off.

*NOTE: If the yellow LED turns on and stays on in steps “c” or “d”, turn the ignition key OFF and retry the procedure. This can happen if:

- The engine is cranked or started
- Communication problems prevent the trouble codes from being cleared or the Learned Fuel Values from being reset to factory default.



Appendix A: Reading Trouble Codes with the Check Engine Lamp

When CMI Lite commands the ECM to “flash out” historic trouble codes at key on, the Check Engine Lamp will use the following sequence:

- 4 seconds on
- Intermission (6 rapid blinks, 3 per second)
- Historic code flash out consisting of:
 - o 2 second pause
 - o 1 second blinks for first digit of trouble code
 - o 2 second pause
 - o 1 second blinks for second digit of trouble code
 - o 2 second pause
- Intermission
- Next historic code flash out

This pattern repeats until all historic codes have been flashed out. The list of codes then repeats until the ignition switch is turned off.

Note: If no historic codes are logged, the intermission will repeat after a 2 second pause.

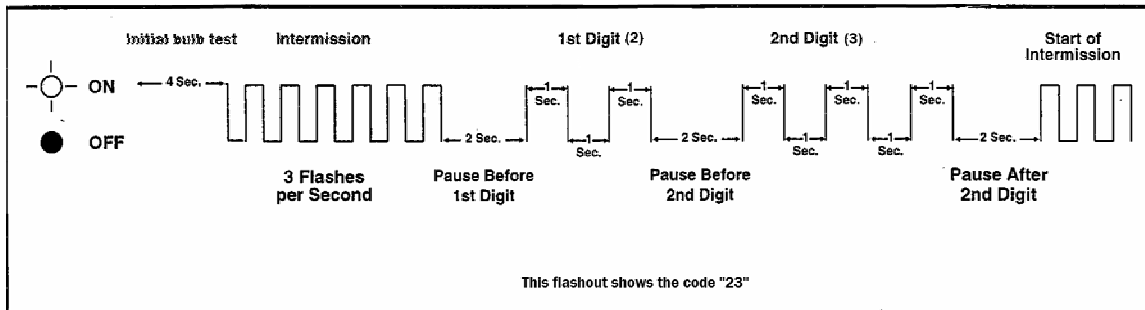



Table 7: Trouble Code Reference

Trouble Code	Name	Condition	Typical Causes
11	TPS	Throttle Position Sensor out of range	Throttle position sensor electrical issue
13	O22	Rear Oxygen sensor stays rich, stays lean, or is inactive	Rear oxygen sensor electrical issue
14	ET	Engine Temperature input out of range	Engine temperature sensor electrical issue
15	AT	Air Temperature input out of range	Air temperature sensor electrical issue
16	Bat	Battery voltage out of range or charging system inoperative	Low battery or charging system problem
17	O21	Front Oxygen sensor stays rich, stays lean, or is inactive	Oxygen sensor electrical issue
18	LFCD	Learned Fuel Cylinder Difference too large	Cylinder wear, fuel injector, or oxygen sensor issues
21	AMC	Active Muffler Control output or feedback issue	Active muffler actuator electrical issue
22	AIC	Active Intake Control fault	Active intake actuator electrical issue
23	Inj1	Front fuel injector fault	Front fuel injector electrical issue
24	Coil1	Front ignition coil fault	Front ignition coil electrical issue
25	Coil2	Rear ignition coil fault	Rear ignition coil electrical issue
26	Clch	Clutch input fault	Clutch switch electrical issue
27	Neu	Neutral input fault	Neutral switch electrical issue
32	Inj2	Rear fuel injector fault	Rear fuel injector electrical issue
33	FP	Fuel Pump fault	Fuel pump electrical issue
34	IAC	Idle Air Control fault	Idle air control motor failure
35	Tach	Tachometer output fault	Tachometer output electrical issue
36	CF	Cooling Fan fault	Cooling fan motor electrical issue
37	VSP	Speedometer output fault	Speedometer output electrical issue
43	VSI	Vehicle Speed Input fault	Vehicle speed input electrical issue
44	BAS	Bank Angle Sensor out of range	Bank Angle Sensor electrical issue
45	SI	Sidestand input out of range	Sidestand switch electrical issue
46	SR	Starter Relay output fault	Starter relay electrical issue
47	APR	Auxiliary Power Relay fault	Auxiliary power relay electrical issue
48	FPS	Fuel Pressure Sensor out of range	Fuel pressure sensor electrical issue
52	RAM	Random Access Memory fault	ECU hardware problem
53	ROM	Read Only Memory fault	ECU flash memory checksum problem
54	EEP	Electrically Erasable Programmable Read Only Memory fault	ECU EEPROM checksum problem
55	ADC	Analog to Digital Converter fault	ECU hardware problem
56	Sync	Engine position sensor synchronization error	Engine position sensor electrical issue, sensor mounting problem, or electromagnetic interference
57	FPC	Unable to maintain Fuel Pressure Control	Out of fuel, fuel pump failure, or fuel pressure sensor failure