

CITY HOOPS

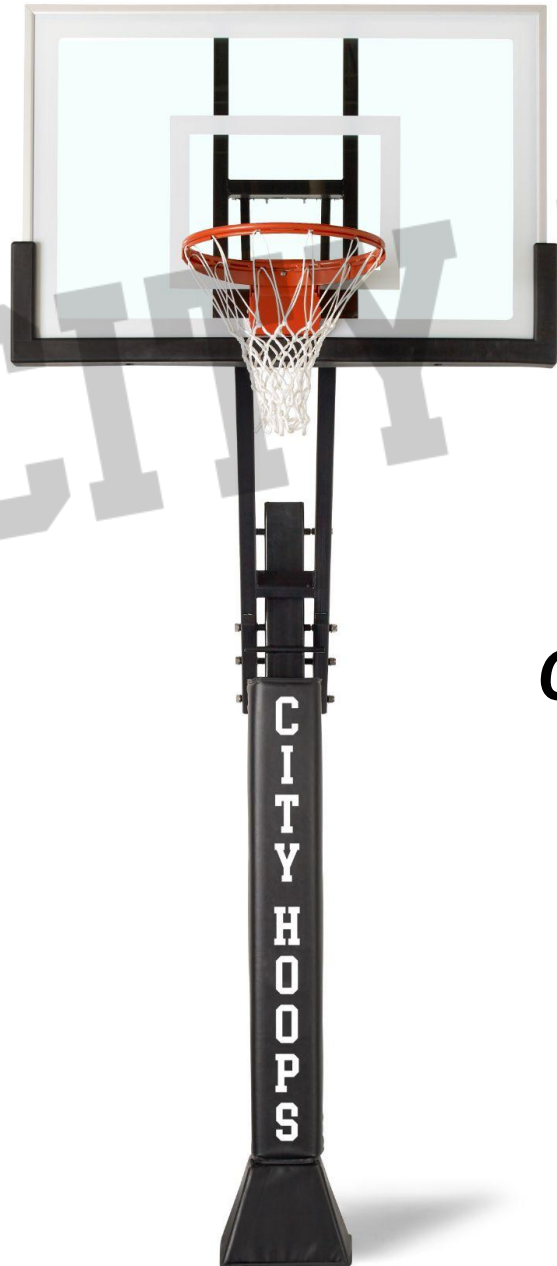

INSTALLATION AND OWNER'S INSTRUCTIONS

SILVER / CHSILV01

SAFETY INSTRUCTIONS

WARNING

FAILURE TO COMPLY WITH ANY OF THE WARNINGS IN THESE INSTRUCTIONS MAY RESULT IN PERSONAL INJURY

FAILURE TO COMPLY MAY ALSO RESULT IN PROPERTY DAMAGE. PLEASE HEED ALL WARNINGS AND CAUTIONS TO ENSURE YOUR SAFETY

DO NOT ATTEMPT TO ASSEMBLE THIS SYSTEM WITHOUT CAREFULLY READING AND FOLLOWING ALL INSTRUCTIONS. BEGIN BY IDENTIFYING AND TAKING INVENTORY OF ALL PARTS USING THE PARTS LIST PROVIDED.

A MINIMUM OF THREE ADULTS IS REQUIRED TO LIFT UNIT INTO PLACE

BEFORE YOU START

- A. Identify and inventory all parts using the checklist boxes in the parts list. Be sure to keep the hardware bags and their contents separate.

If any parts are missing call our Customer Service Department 1(866)-611-8552.

- B. Test fit all bolts by inserting them into the respective hole. If necessary, carefully scrape away any excess powder coating buildup from inside the holes. Do not scrape away all of the powder coating. Bare metal may rust.

SAFETY INSTRUCTIONS

FAILURE TO FOLLOW THESE SAFETY INSTRUCTIONS MAY RESULT IN SERIOUS INJURY OR PROPERTY DAMAGE AND WILL VOID THE WARRANTY. The owner must ensure that all players know and follow these rules to safely operate the system. Proper and complete assembly, use and supervision is essential for proper operation and to reduce the risk of accident or injury. A high probability of serious injury exists if this system is not installed, maintained, or operated properly.

- If using a ladder during assembly, use extreme caution. Follow all warnings and cautions on the ladder carefully.
- 3 people are required to lift the unit into place.
- Before digging, contact the appropriate agency to locate underground power cables, gas, and water lines. Do not install the system within 20 feet of overhead power lines.
- Climate, corrosion, or misuse could result in system failure.
- If technical assistance is required, contact the manufacturer.
- Minimum operational height is 5' to the Rim. Most injuries are caused by misuse and /or failure to follow instructions. Use caution when using the system.

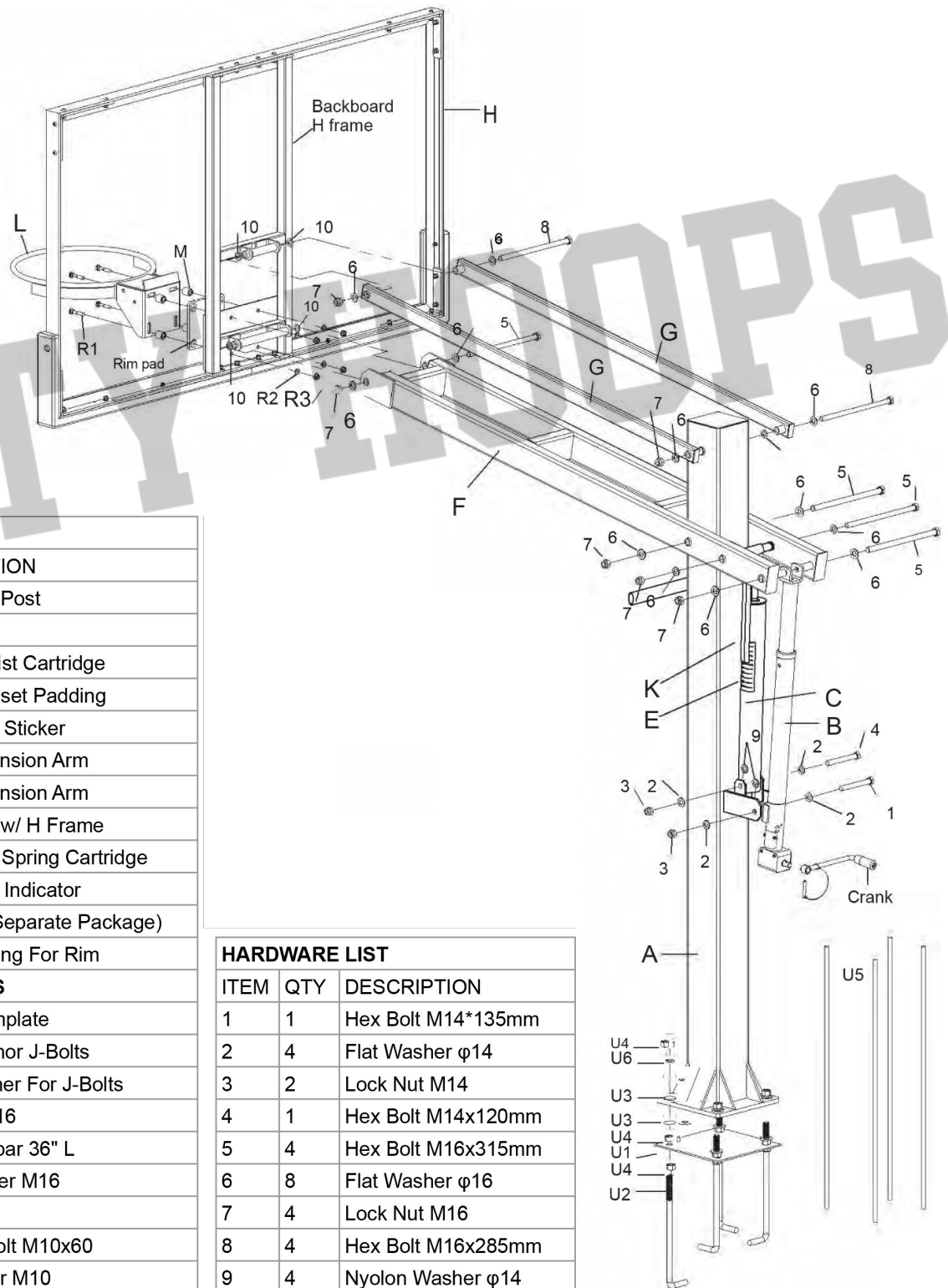

PARTS LIST

ITEM	QTY	DESCRIPTION
A	1	5"x5" Main Post
B	1	Actuator
C	1	Spring-Assist Cartridge
D	1	Pole & Gusset Padding
E	1	Rim Height Sticker
F	1	Lower Extension Arm
G	2	Upper Extension Arm
H	1	Backboard w/ H Frame
I	1	Sleeve For Spring Cartridge
K	1	Rim Height Indicator
L	1	Flex Rim (Separate Package)
M	4	Steel Bushing For Rim

UNDERGROUND PARTS

U1	1	Anchor Template
U2	4	16mm Anchor J-Bolts
U3	8	Thick Washer For J-Bolts
U4	12	Hex Nut M16
U5	4	Anchor Rebar 36" L
U6	4	Lock Washer M16

RIM HARDWARE

R1	4	Carriage Bolt M10x60
R2	4	Flat Washer M10
R3	4	Flange Nut M10

HARDWARE LIST

ITEM	QTY	DESCRIPTION
1	1	Hex Bolt M14*135mm
2	4	Flat Washer φ14
3	2	Lock Nut M14
4	1	Hex Bolt M14x120mm
5	4	Hex Bolt M16x315mm
6	8	Flat Washer φ16
7	4	Lock Nut M16
8	4	Hex Bolt M16x285mm
9	4	Nylon Washer φ14
10	12	Nylon Washer φ16

IN-GROUND ANCHOR SYSTEM

STAGE 1 OF 2

Tools & Materials Required For Complete Installation

- | | | | |
|----|-----------------------|-----|--|
| 1. | 2 Adjustable Wrenches | 10. | Concrete - ½ Yard or 14-16 |
| 2. | Socket Set | | Bags, (30kg / 66lb each) |
| 3. | 9/16" Wrench | 11. | Phillips Head Screwdriver |
| 4. | ¾" Wrench | 12. | A minimum of 2 Ladders |
| 5. | 15/16" Wrench | 13. | Spirit / Bubble / Carpenter Level |
| 6. | ½" Wrench | 14. | Water Supply |
| 7. | Hammer or Mallet | 15. | Pole hole digger / earth auger |
| 8. | Tape Measure | 16. | 20" Sonotube IF REQUIRED |
| 9. | Shovel | | 24" Sonotube (for Diamond) IF REQUIRED |

STEP 1 (Digging The Footing)

Before digging, call to locate any buried utility lines.

NOTE: The back of the anchor kit must be 15 inches away from any wall, fence, or obstruction to allow room for the adjustable crank.

- A. Dig a hole 48" deep and 21"x 21"square: The edge of hole should be flush with the edge of the playing surface. If you live in an area where heavy frost can occur, it may pose a problem, consult your local building inspector to determine appropriate hole depth.

NOTE: Hole must be at least 48" deep.

- B. Build a form before pouring the concrete pad, to ensure that the top of the concrete remains straight and square. The form should be placed about 1/2" above the playing surface to allow for water drainage.
- C. Bell out the bottom of the hole.

NOTE: A square hole prevents the rotation of the concrete.

NOTE: The area behind the playing surface must be cleared off by at least 3 feet to enable the user to stand behind the pole to adjust the rim height.

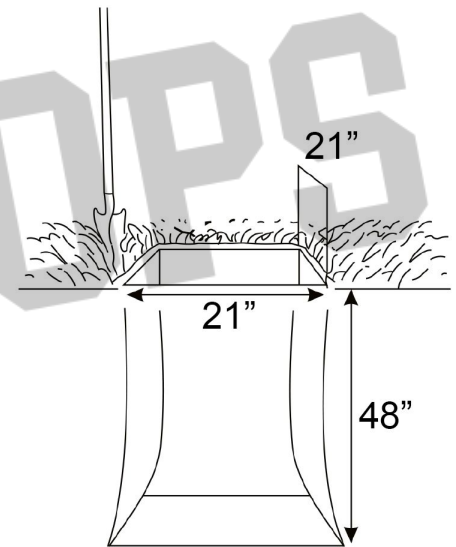

STEP 2 (Assembling Anchor Template)

- D. Thread a 16mm Hex Nut (U4) onto each of the 16mm J-Bolts (U2). Securely tighten the nuts all the way down to the end of the threads.
- E. Slide the threaded end of the J-Bolts through the holes in the Anchor template (u1) and secure each J-Bolt with a 16mm J-Bolt Hex Nuts (U4) as shown. Securely tighten all nuts at this time.

NOTE: Make sure the curved "J" ends of the J-Bolts are oriented in a rectangular pattern, as shown.

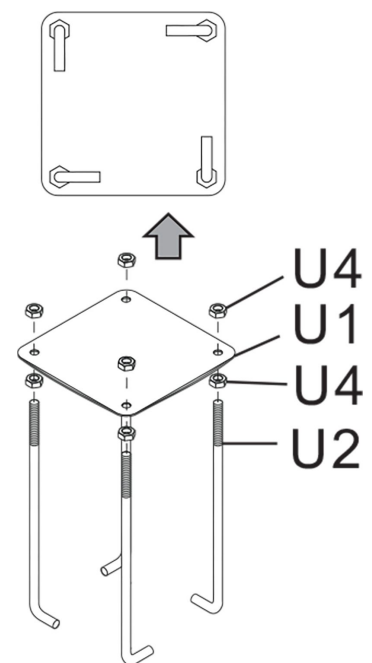
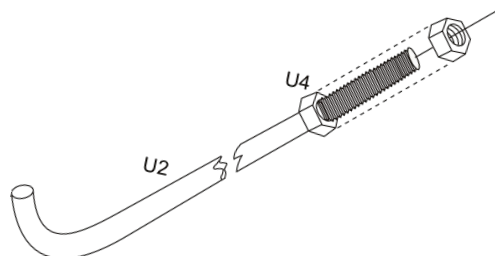

STEP 3 (Concrete)

- F. Mix the concrete according to the instructions on the bags. Note that a thicker mix of concrete will dry stronger than a thin mix. Pour the concrete into the hole, stopping approximately 18 inches from the top of the hole.
- G. Insert the four pieces of Anchor Rebar (U5) into the hole, pushing each piece firmly to the bottom of the hole. The four pieces should be arranged in a square approximately 8 inches wide so that each piece of rebar will be positioned next to the J-Bolts when the J-Bolt template is placed in the concrete.
- H. Finish filling the hole to the top with concrete. The top of the concrete should reach just above the level of the top of the form.

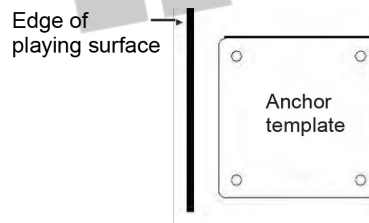
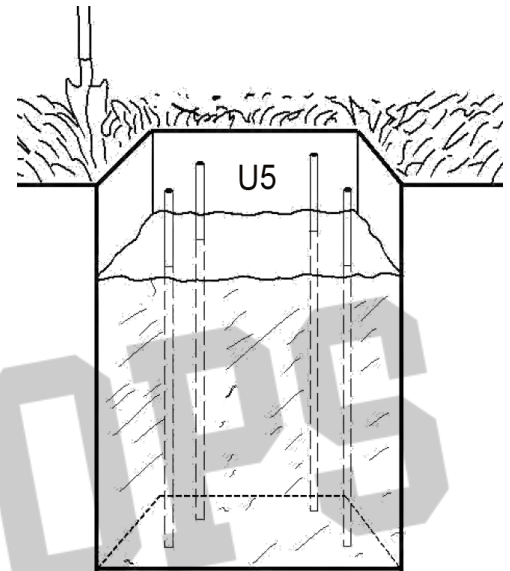

STEP 4 (Inserting J-Bolt Anchor Template)

- I. Position the J-Bolt Template (U1) over the wholes as shown with sides of the plate square with the sides of the hole / court.
- J. Push the J-Bolts (U2) into the concrete until the J-Bolt Template is resting flat approximately 1" above the surface of the concrete.
- K. Grasp the tops of the J-Bolts and agitate the Template assembly back and forth repeatedly to eliminate any air bubbles in the concrete. Lift the Template slightly above the concrete when agitating. Make sure the Template is resting on the concrete after agitating. Form the concrete into a downward slope away from the Pole (center) to allow water runoff.
- L. Clean any concrete that may be on the J-Bolt Template or the exposed portions of the J-Bolts.
- M. Using a spirit / bubble level, make sure the Template is square to and level with the playing service.
- O. Allow the concrete to cure for a minimum of 5-7 days.

Playing surface
(Front side)

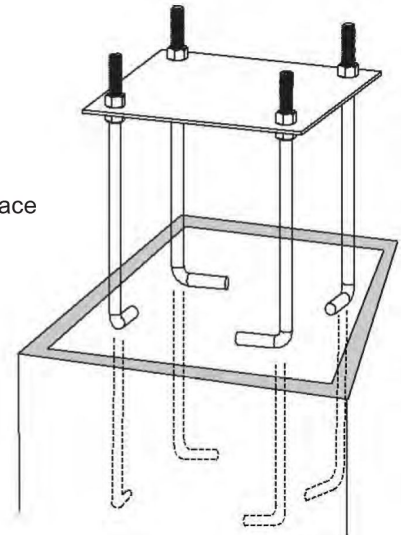

YOU ARE NOW FINISHED WITH THE INITIAL ASSEMBLY STEPS. DO NOT PROCEED WITH THE REMAINING ASSEMBLY UNTIL THE CONCRETE HAS FULLY CURED. CURING WILL TAKE A MINIMUM OF 5-7 DAYS. IN HUMID CLIMATES OR WET WEATHER, ALLOW ADDITIONAL TIME FOR THE CONCRETE TO CURE.

ASSEMBLY OF YOUR CITY HOOPS BASKETBALL SYSTEM

STAGE 2 OF 2

WARNING

NEVER USE THE SYSTEM WITHOUT FOLLOWING THE CEMENTING & CONCRETE INSTRUCTIONS. FAILURE TO FOLLOW ALL THESE INSTRUCTIONS AND WARNINGS COULD LEAD TO SERIOUS PERSONAL INJURY OR PROPERTY DAMAGE AS LISTED ON PAGE 2.

Tools & Materials Required For Complete Installation

- | | | | |
|----|-----------------------|-----|-----------------------------------|
| 1. | 2 Adjustable Wrenches | 10. | Concrete - 1/2 Yard or 14-16 |
| 2. | Socket Set | | Bags, (30kg / 66lb each) |
| 3. | 9/16" Wrench | 11. | Phillips Head Screwdriver |
| 4. | 3/4" Wrench | 12. | A minimum of 2 Ladders |
| 5. | 15/16" Wrench | 13. | Spirit / Bubble / Carpenter Level |
| 6. | 1/2" Wrench | 14. | Water Supply |
| 7. | Hammer or Mallet | | |
| 8. | Tape Measure | | |
| 9. | Shovel | | |

WARNING

DUE TO THE SIZE AND WEIGHT OF THE SYSTEM, A MINIMUM OF THREE ADULTS ARE REQUIRED FOR THE FOLLOWING STEPS

STEP 1 (Assembling The Vertical Post)

- Slide a 16mm Thick Washer (U3) over each of the J-Bolts (U2) as shown in FIGURE 1A
- Remove the Padding from Main Post (A). Place the Main Post (A) over the J-Bolts. Slide a 16mm Thick Washer (U3), a Lock washer M16 (U6) and thread a 16mm Hex Nut (U4) to each J-Bolt. Tighten the nuts only a few turns onto the J-Bolts as shown in FIGURE 1B.
- If the Main Post (A) is not exactly vertical, adjust the 16mm J-Bolt Hex Nuts (U4) located under the Post Base. Tighten all of the Hex Nuts (U4) above Post Base when Main Post (A) is vertical.

NOTE: Face the Main Post (A) with Actuator Bracket facing away from the playing court (as shown in FIGURE 1C.)

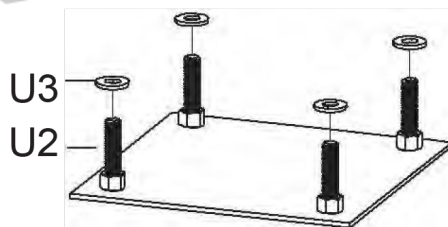

FIGURE 1A

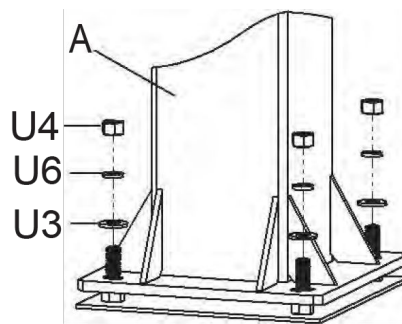

FIGURE 1B

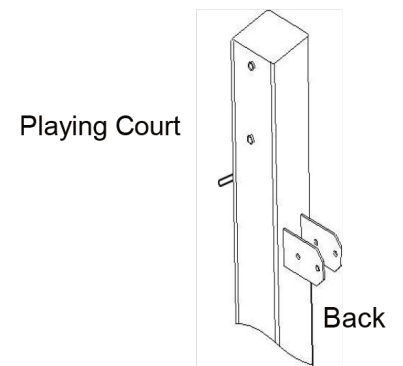
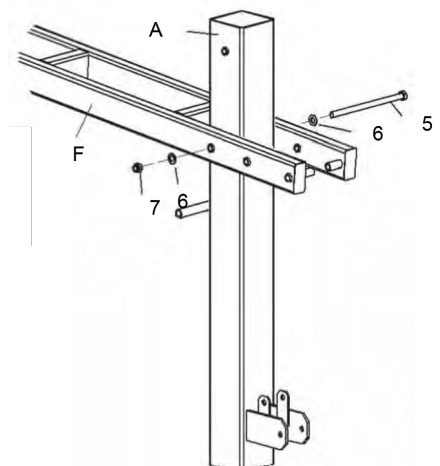

FIGURE 1C

STEP 2 (Assembling Main Extension Arm)

- Slide the Main Extension Arm (F) over the top of the Main Post (A) and attach to the lower pivot tube with one Hex Bolt M16x315mm (#5), two flat washer M16 (#6), and one lock nut M16 (#7)

NOTE: DO NOT OVER TIGHTEN THIS BOLT AND NUT



STEP 3 (Assembling Adjustable Actuator)

- A. **Connect Actuator to Main Extension Arm**
Place the upper bracket of Actuator (B) between last set of welded tubes on the Main Extension Arm (F), attach the two parts using Hex Bolt M16x315mm (#5), two Flat Washers M16 (#6), one Lock Nut (#7),
- B. **Connect Actuator (B) to mounting bracket welded in middle of Post (A)**, using one Hex Bolt M14x120mm (#1), two flat washers for M14 Bolt (#2), and one Lock Nut for M14 bolt (#3)

Note: Crank handle may be pre-installed.

- C. **Attach Crank Handle to the actuator.** Slide Removable Crank Handle onto the shaft sticking out of Gear Box (Actuator), lock it in place with attached pin.

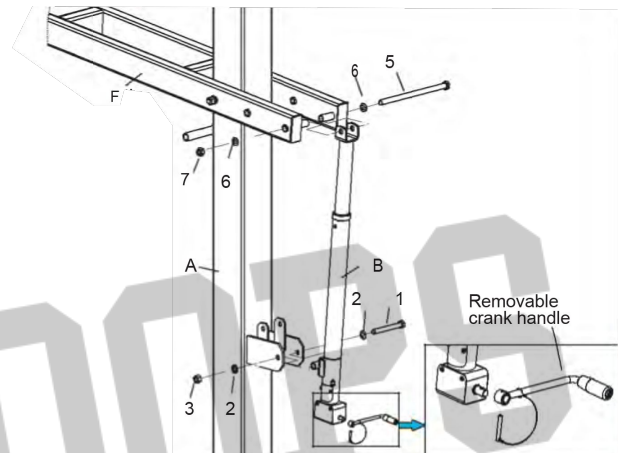

STEP 4 (Assembling Spring Cartridge)

- A. Slide Steel Sleeve (J) thru the tube welded at the top end of Spring-Assist Cartridge (C). Place the top of Spring-Assist between Main Extension (F), align the Steel Sleeve (J) with the second set of welded tubes on the Main Extension Arm (F), place the steel rim Height Indicator (K) beside the Spring-Assist Cartridge (C).

Slide one Washer M16 (#6) over one Hex Bolt M16x315mm (#5), and slide this Bolt all the way thru Main Extension Arm (F), Steel Sleeve (J), Rim Height indicator (K), and the other side of Main Extension Arm (F). Secure it with one Flat Washer M16 (#6), and One Lock nut M16 (#7).

Do not over tighten this bolt because this is the pivot point. Make sure the Stainless steel Rim Height Indicator(K) hang freely along side of Spring-Assist Cartridge

- B. Attach the bottom of Spring-Assist Cartridges to the Main Pole Bracket by using a Hex Bolt M14x120mm (#4), two Flat Washers M14 (#2), and one Lock Nut M14 (#3).
- C. Remove and discard the spreader bracket from the cartridge.

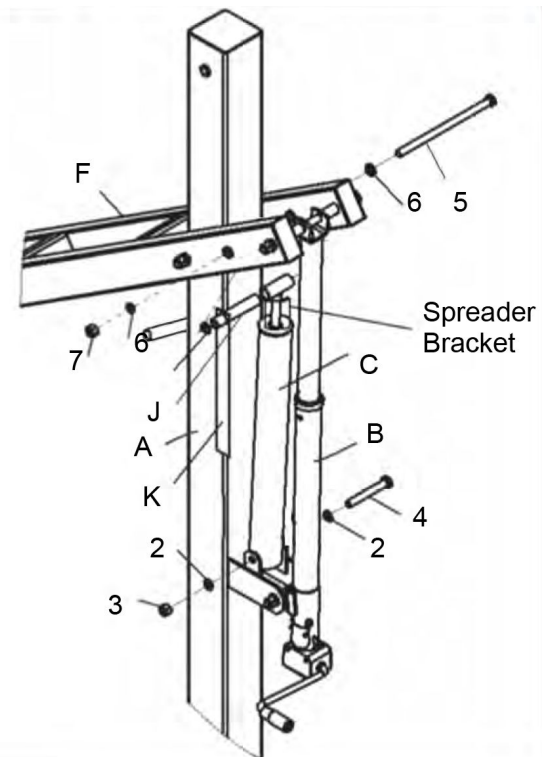

STEP 5 (Assembling Upper Extension Arms)

- A. Attach the 2 Upper Extension Arms (G) to Main Post (A), with a Hex Bolt M16x285mm (#8), two Flat Washers M16 (#6), and One Lock Nut (#7).

CAUTION:
Injury may occur if Upper Extension Arms are allowed to fall off Main Extension Arm during assembly.

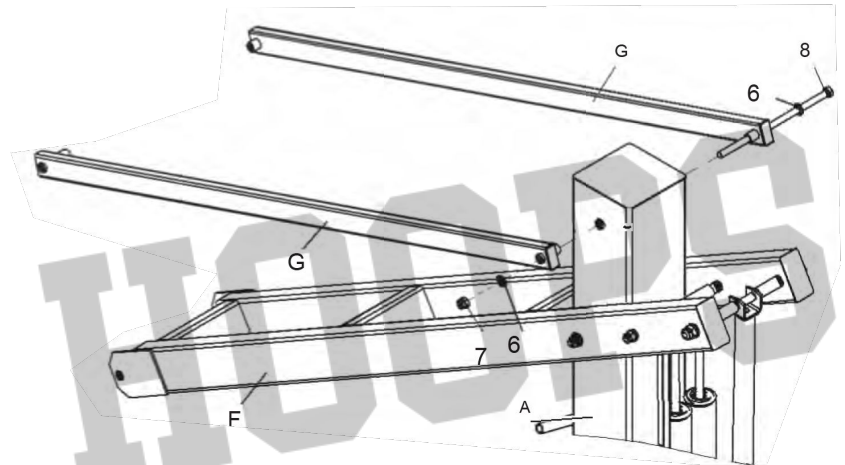

STEP 6 (Assembling Backboard To Extension Arms)

- A. Attach the Backboard To Main Extension Arm (F) by using one Hex Bolt M16x315mm (#5), two Flat Washers M16 (#6), one Lock Nut M16 (#7). **Note: Do not over tighten Main Extension Arm (F) in this step.**

Repeat the same process with Upper Extension Arm (G) by using one Hex Bolt M16x285mm (#8), two Flat Washers M16 (#6), one Lock Nut M16 (#7).

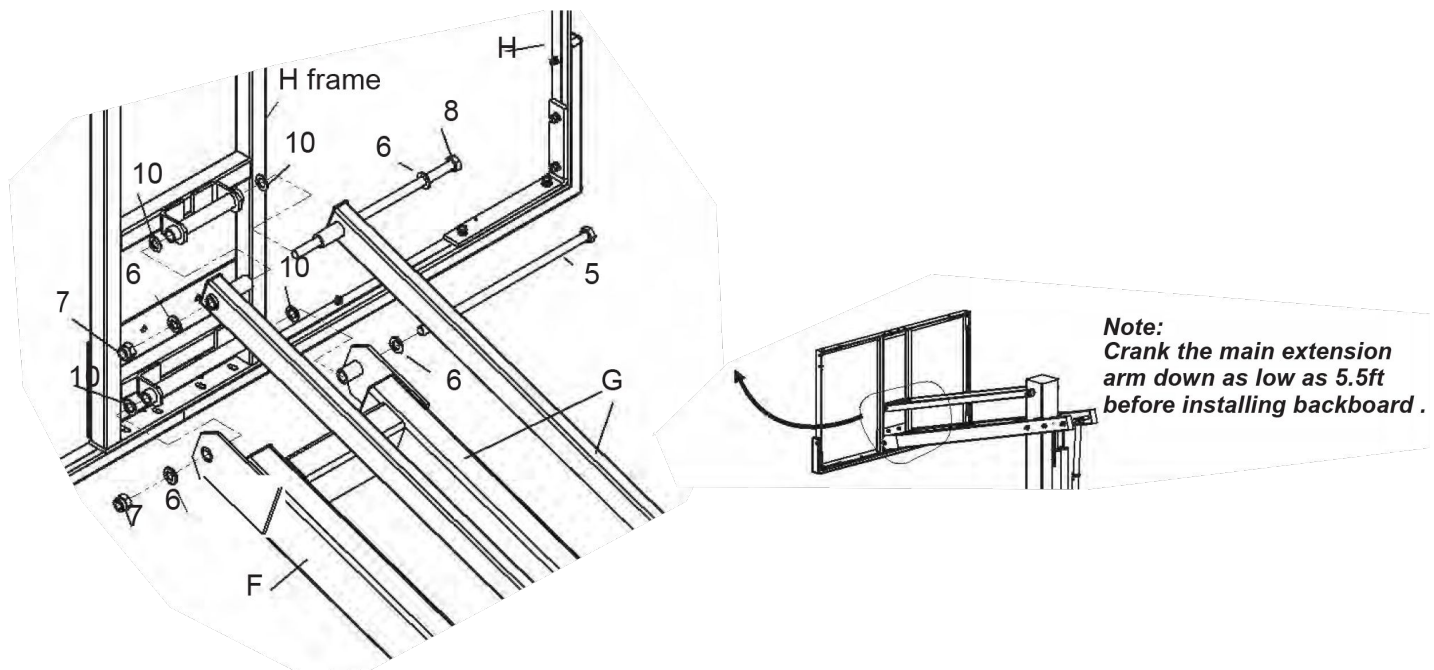

STEP 7 (Assembling Rim To Backboard)

- A. Insert the 4 Plastic and Steel Spacers (M) into the 4 holes on the backboard.

CAUTION: Do not proceed with rim installation without these spacers.

- B. Remove the screws on Rim Spring Box Cover, open the Spring Box. (Rim cover may be separate in the package)
- C. Mount the rim to the H-Frame Backboard Mount (H) and Backboard Assembly using the hardware supplied in rim box.
- D. Reattach Spring Box Cover to the Rim with removed screws.

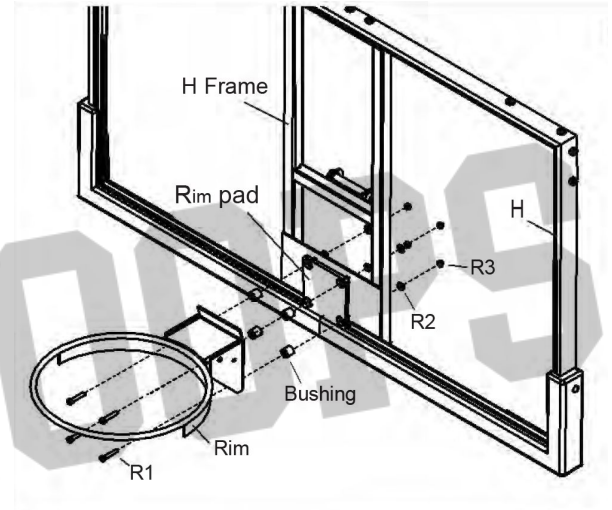

NOTE: Use a level to make sure rim is level side to side before tightening bolts.

STEP 8 (Assembling Rim Height Sticker)

- A. After everything is square / level, make sure all nuts on the system have been tightened.

NOTE: Do not over tighten the Nuts, make sure the unit can be adjusted up and down.

- B. To apply the Rim Height Sticker (in the manual pack), first use a tape measure to crank rim up to exactly 10' from the playing surface. Use a pencil or non permanent marker to make a mark on the Spring Assist Cartridge (C) where the bottom of the Rim Height Indicator (K) stops.

Peel and apply Rim Height Sticker to outside of Spring-Assist Cartridge © lining up the pencil mark with the 10' mark on the Rim Height Sticker. See Detail A

- C. Attach Post Pad & Gusset Pad to Main Post (A) as shown.

