



HATSAN
ARMS COMPANY

Serious. Solid. Impact.



GALATIAN AUTO SERIES

INSTRUCTION MANUAL

PLEASE READ THIS MANUAL BEFORE USING YOUR AIR GUN

CONTENTS	PAGE
GENERAL INSTRUCTIONS	3
SPECIFICATIONS	4
BASIC PARTS OF YOUR GUN	5
MANUAL SAFETY	6
REAR SIGHT ADJUSTMENT	6
OPERATING INSTRUCTIONS	6
LOADING THE RIFLE & SHOOTING	7
MAINTENANCE	8
SAFETY MEASURES & WARNINGS	9

Thank you for choosing Galatian Auto series semi-auto action PCP air rifle!

Always use caution when operating this air rifle. Learn and obey the laws of your local municipality, state, and/or country. Demonstrate responsibility while using this air rifle. **Please read the entire manual very carefully before use.** Any damage or injury resulting from misuse or incorrect handling is the sole responsibility of the owner.

This air rifle allows you to fire multiple pellets and makes shooting a lot more fun giving you more chances to hit your target. This air rifle is cocked and reloaded all at once upon the pulling of the trigger. Squeezing the trigger not only opens the air valve to fire the loaded pellet, it also automatically loads the next round and resets the air valve. This enables you to shoot pellets one after another as quickly as you are able to pull the trigger and not have to reload until the rotatory magazine is empty.

Warning!

- **Each Hatsan PCP air gun contains pressurized air and should only be dismantled by a competent gunsmith. Otherwise serious damage/injury/death may be caused to you or others. The air rifle may also become damaged. Never attempt to dismantle the air tube or air gauge when the air tube is fully or partially charged. Serious injury/death/damage may result if these instructions are ignored.**
- **Use only factory manufactured pellets that are no longer than the thickness of the air rifle's magazine. Do not use BB ammunition with your air rifle.**
- **Hatsan PCP air guns are designed specifically for use with dry compressed air. NO OTHER GAS OR GAS COMBINATION CAN BE USED.**

The air rifle may be filled from a hatsan hand pump, diver's bottle or a suitable compressor, MAXIMUM SAFE WORKING PRESSURE (SWP): 200 BAR.

GENERAL INSTRUCTIONS

Before using your new air rifle, check that it is fully charged and abide by the following basic safety rules:

Basic Safety Rules:

- Treat every gun as if it is loaded.
- Never point the air gun at anyone, or allow anyone to point an air gun at you, even if you know it is not loaded.
- Do not brandish or display this product in public – as it may confuse people and could be mistaken for a firearm.
- Always carry the air rifle so that the direction of the muzzle is under control, even if you stumble.
- Always be sure of your target and what lies behind it before firing your air rifle – this product may be dangerous up to 650 yards.
- Beware of targets that tend to cause ricochets.
- Never leave a loaded air rifle unattended.
- It is compulsory that eye & ear protection is worn when charging the air tube and when shooting.
- This is a high-powered air gun for use by those 16 years of age or older.

Section I. SPECIFICATIONS

The Hatsan Galatian Auto series semi-auto PCP air rifle has a 14-shot magazine in .177 (4.5mm), 12-shot magazine in .22 (5.5mm), and 10-shot magazine in .25 (6.35mm) caliber. This is a pre-charged pneumatic, semi-automatic air rifle with a detachable 255cc aluminum air cylinder tube.

Model	Caliber	Max Muzzle Velocity Lead Pellet (*)	Energy (*)		Magazine Capacity	Air Tube Volume	Fill Pressure
			Joules	ft.lbs			
Galatian 5 Auto	4.5mm / .177cal	310m/s (1020fps)	27	20	14	255cc	200 BAR
	5.5mm / .22cal	288m/s (950fps)	39.8	29	12	255cc	200 BAR
	6.35mm / .25cal	265m/s (870fps)	45	33.5	10	255cc	200 BAR

Model	Number of Semi Automatic Shots at Optimal Velocity (**)	Stock	Overall Length	Barrel Length	Weight	Fiber Optic Sights Diameters	
						Rear Sight	Front Sight
Galatian 5 Auto	50	High Quality Turkish Walnut	1068mm (42")	500mm (19.7")	3.7kg (8.1lbs)	0.9mm (.035") green	1.5mm (.060") red
	50						
	50						

Model	Caliber	Max Muzzle Velocity Lead Pellet (*)	Energy (*)		Magazine Capacity	Air Tube Volume	Fill Pressure
			Joules	ft.lbs			
Galatian 6 Auto	4.5mm / .177cal	310m/s (1020fps)	27	20	14	255cc	200 BAR
	5.5mm / .22cal	288m/s (950fps)	39.8	29	12	255cc	200 BAR
	6.35mm / .25cal	265m/s (870fps)	45	33.5	10	255cc	200 BAR

Model	Number of Semi Automatic Shots at Optimal Velocity	Stock	Overall Length	Barrel Length	Weight	Fiber Optic Sights Diameters	
						Rear Sight	Front Sight
Galatian 6 Auto	50	Advanced Polymer	1068mm (42")	500mm (19.7")	3.85kg (8,5lbs)	0.9mm (.035") green	1.5mm (.060") red
	50						
	50						

Model	Caliber	Max Muzzle Velocity Lead Pellet (*)	Energy (*)		Magazine Capacity	Air Tube Volume	Fill Pressure	Number of Semi Automatic Shots at Optimal Velocity
			Joules	ft.lbs				
Galatian Tact Auto	4.5mm / .177cal	310m/s (1020fps)	27	20	14	255cc	200 BAR	50
	5.5mm / .22cal	288m/s (950fps)	39.8	29	12	255cc	200 BAR	50
	6.35mm / .25cal	265m/s (870fps)	45	33.5	10	255cc	200 BAR	50

Model	Stock	Overall Length	Barrel Length	Weight	Fiber Optic Sights Diameters	
					Rear Sight	Front Sight
Galatian Tact Auto	Tactical Telescopic Stock Adjustable Comb Advanced Polymer Grip	Butt Shortened: 970mm (38.1")	500mm (19.7")	4.15kg (9.1lbs)	0.9mm (.035") green	1.5mm (.060") red
		Butt Extended: 1075mm (42.3")				

* Velocity results may vary as much as 20% due to pellet weight, pellet shape, temperature, elevation, as well as other factors.

** Minimum 100 bar pressure necessary for semi auto action.

Section II. BASIC PARTS OF YOUR GUN

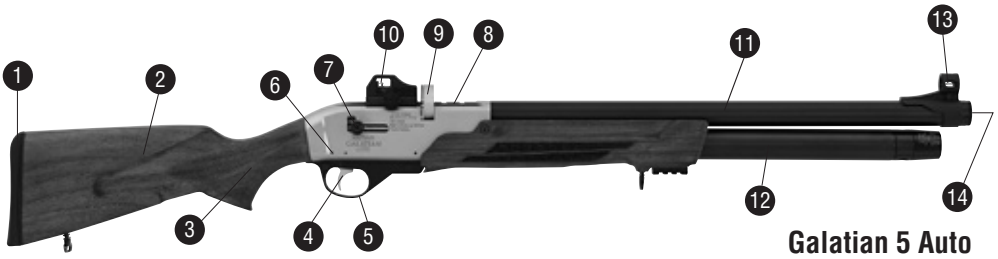

Galatian 5 Auto

- | | | |
|------------------|-------------------|------------------------|
| 1. Butt Pad | 6. Receiver | 11. Barrel with shroud |
| 2. Stock | 7. Cocking Handle | 12. Air Cylinder Tube |
| 3. Grip | 8. Scope Rail | 13. Front Sight |
| 4. Trigger | 9. Magazine | 14. Muzzle |
| 5. Trigger Guard | 10. Rear Sight | |

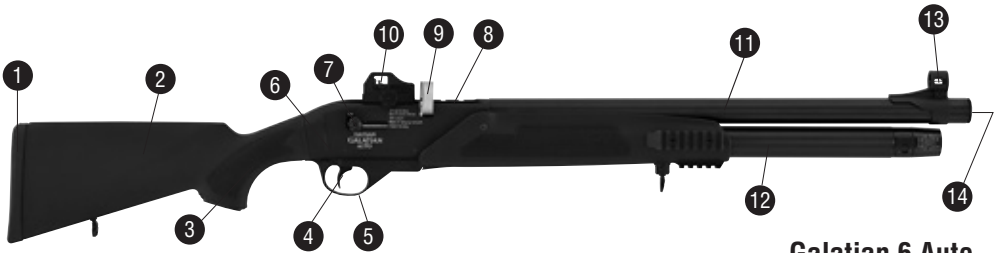

Galatian 6 Auto

- | | | |
|------------------|-------------------|------------------------|
| 1. Butt Pad | 6. Receiver | 11. Barrel with shroud |
| 2. Stock | 7. Cocking Handle | 12. Air Cylinder Tube |
| 3. Grip | 8. Scope Rail | 13. Front Sight |
| 4. Trigger | 9. Magazine | 14. Muzzle |
| 5. Trigger Guard | 10. Rear Sight | |

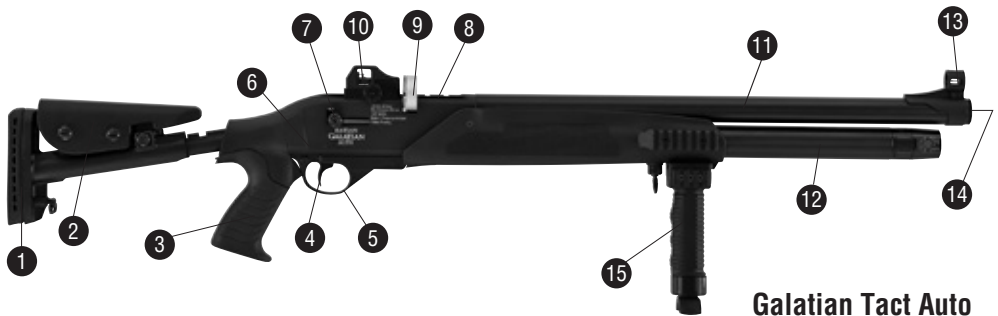

Galatian Tact Auto

- | | | |
|------------------|-------------------|------------------------|
| 1. Butt Pad | 6. Receiver | 11. Barrel with shroud |
| 2. Stock | 7. Cocking Handle | 12. Air Cylinder Tube |
| 3. Grip | 8. Scope Rail | 13. Front Sight |
| 4. Trigger | 9. Magazine | 14. Muzzle |
| 5. Trigger Guard | 10. Rear Sight | 15. Foregrip |

Section III. MANUAL SAFETY



Safety button can be set to 'ON' and 'OFF' position manually.

Safety button It is located **behind** the trigger on the trigger housing.

When the red ring on its left side is visible, it means that the cross button safety is disengaged ("OFF") and air rifle is ready to shoot. (Fig. 1)

To engage the cross button safety, push it fully to the right until its red ring disappears and it will move no further. The safety is now **ON**, blocking the trigger from being pulled. (Fig. 2)

To take the safety "OFF", push the button fully to the left, exposing its red ring. The trigger can now be pulled.

CAUTION: Until you are actually ready to shoot, keep the safety in the "ON" position (Fig. 2)

Section IV. REAR SIGHT ADJUSTMENT

The Galatian Auto air rifle has optional fiber optic rear & front sight assemblies. The rear-sight is a sensitive device and can be adjusted both for elevation and windage.

Windage adjustment

If the shot is left of the target, turn the **SCREW#1** clockwise.

(Fig. 3)

If the shot is right of the target, turn the **SCREW#1** counter-clockwise. (Fig. 3)

Elevation adjustment

If the shot is too high, turn **SCREW#2** clockwise. (Fig. 3)

If the shot is too low, turn **SCREW#2** screw counter-clockwise. (Fig. 3)

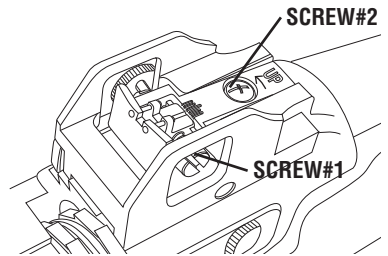

Section V. OPERATING INSTRUCTIONS

Warning!

- Use caution when operating the Galatian Auto series from the left handed shooting position. The bolt located on the right hand side of the rifle cycles with each shot fired and may cause injury if operated left handed.
- Before filling the air cylinder; make sure the safety is in the ON position, no pellets are loaded in the air rifle and/or barrel and magazine is not mounted in the gun. If the air bottle is completely empty; fill in air bottle after cocking the gun and keeping the cocking handle/bolt lever open at the rear.
- Take all safety measures before filling the air bottle. It is compulsory for the user and bystanders to wear eye & ear protection when filling the air bottle.
- While filling in the air bottle; the pressure in it must be monitored from the air gauge of the hand pump or scuba charging kit. Do not look at the air gauge on the air rifle during filling process. Instead, reference the gauge on your fill device.

1. Pull the bolt lever backwards until it stops and locks at the back. Keep the bolt lever locked at the rear. (Fig. 4)

THIS OPERATION COCKS THE TRIGGER MECHANISM/HAMMER ASSEMBLY.

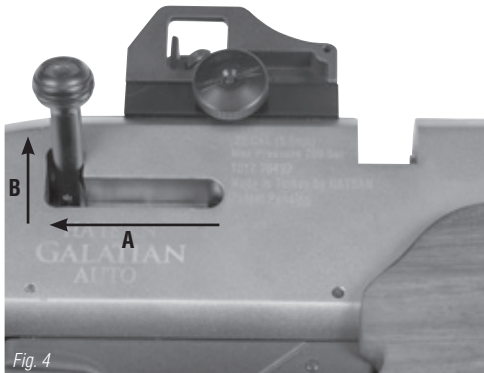

Fig. 4



Fig. 5

Fit the filler nozzle to the air-line of the charging equipment, which must incorporate a pressure gauge. Ensure both filler nozzle and rifle filler hole are clear from dirt and gently push the nozzle into the filler hole. **(Fig. 5)**

Fill the air tube up pressure quoted previously in this manual. Do not exceed the maximum fill pressure as this will reduce the muzzle velocity of the pellets and may damage pistol components which may cause danger to you and others around you.

When using the diver's bottle, refill the rifle slowly to prevent the heat created by the filling process from damaging the rifle's components. Undo the bleeder valve on the hose before disconnecting the fill nozzle from the rifle.

Loading the rifle & shooting

1. The magazine is composed of a rear side (transparent part) and a front side (aluminum part). The magazine is designed to be allowed to fit only one way into the rifle.
2. Hold the magazine with its aluminum side over the transparent side. **(Fig. 6)**



Fig. 6



Fig. 7

3. Spin the aluminum side counter-clockwise to release the cover from the catch point. Then insert the pellet in backwards (skirt first) into the first location. **(Fig. 7)**

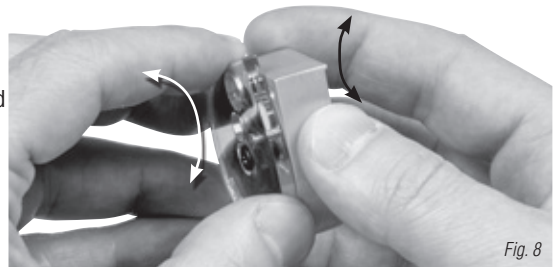

Fig. 8

4. Spinning the cover in the same direction and holding the magazine in a vertical position continue placing the pellets until the all positions are filled. Once the magazine is full, spin the aluminum side in the opposite direction and return the magazine to its initial position. **(Fig. 8)**



With the transparent cover facing the butt of the rifle insert the magazine from the right side of the rifle and push it inwards all the way in until it's fully in place. (Fig.9 & 10)

DO NOT RELEASE THE BOLT LEVER UNTIL YOU ARE READY TO FIRE.

6. Once you are ready to fire, release the bolt lever and move it all the way forward. (Fig.11)

7. Aim at your intended target, disengage the safety and get ready to shoot.

8. Pull the trigger. The rifle will fire and re-cock the bolt at the same time.

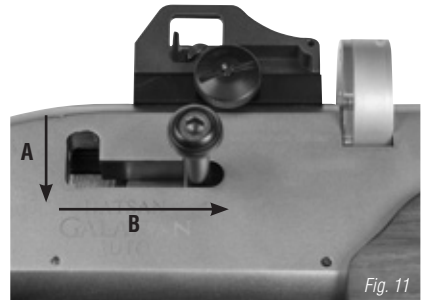

Warning!

Your rifle is able to shoot as a semi-automatic rifle as long as the pressure inside the air bottle is above 100 bars.

Make sure the bolt lever is closed fully before you shoot.

In case of a malfunction, pull the bolt lever, remove the magazine and squeeze the trigger aiming your rifle in a safe direction. Then insert the magazine again.

Never re-cock your rifle without shooting. Each time you re-cock the bolt lever without firing, it will feed a pellet into the barrel, which will lead to a pellet accumulation inside the barrel.

If shooting does not happen after squeezing the trigger, immediately remove the magazine and pull the trigger pointing your rifle in a safe direction. Otherwise you may accidentally leave a pellet in the barrel.

Section VIII. MAINTENANCE

Warning!

Never attempt to disassemble this rifle. Never fire the rifle when the air in the cylinder is removed.

Failure to obey this instruction could result in damage to your rifle.

Never lubricate inside the barrel as this will affect the accuracy & grouping of the rifle in negative manner. Occasionally apply proper mineral based oils sparingly to the following parts:

- The trigger mechanism
- The pellet probe
- The cocking lever sliding surface

DO NOT OVER-LUBRICATE THE RIFLE!

- It is recommended to clean the barrel with a cleaning rod every 500-1000 shots. Never lubricate inside the barrel.
- Before you begin oiling or cleaning your air gun, always check to make sure it is unloaded.

- Always be sure your gun barrel is clean and not blocked.
- After cleaning ensure that no cleaning patch or other obstruction remains in the barrel.
- Annually, take your air gun to a gunsmith even if it seems to be working well, since some issues in your gun may not be apparent from external examination.
- Take your air gun to a gunsmith if water, sand, etc. enters the internal mechanism of the air gun, for complete cleaning.
- Dangerous conditions may occur if you do not keep your air gun clean and working properly.

QUICK FILL NOZZLE O-RINGS REPLACEMENT

- After a period of time, the O-rings on the fill nozzle will need to be replaced. The need for the replacement will become noticeable if air is heard leaking from the nozzle or the nozzle is ejected from the port while charging the rifle. Always replace both O-rings.

Safety Measures & Warnings

- This air gun will fire if cocked, loaded, safety disengaged and trigger pulled.
- Air guns are not toys. Never let young children use an air gun unsupervised. Adult supervision is strictly required during use. Misuse or careless use may cause serious injury or death.
- This is a high-powered airgun for use by those 16 years of age or older.
- Learn how your air gun operates and practice safe gun handling procedures before loading and using it.
- **ALWAYS USE EYE & HEARING PROTECTION AND MAKE BYSTANDERS USE THE SAME.** Failure to do so may result in eye injuries and permanent hearing loss.
- Do not point at anything you do not intend to shoot even though the gun is unloaded. Always keep the gun pointed in a safe direction.
- Never pull a gun toward you by the muzzle.
- Always aim at a safe target, taking care that it does not conceal any other object.
- Before you fire, consider where the pellet will travel should you miss your intended target, thus ensuring no damage or harm could result.
- Be sure of your target before you pull the trigger. Never shoot at sounds.
- When shooting, always have a safe shooting range, that is; have a safe area for shooting, a safe distance between you and the target, and a safe backstop to trap the pellets and hold the target.
- Do not fire at a target, which allows ricochets or deflections. Do not fire into or at water.
- Do not fire at or near power lines or insulators. Be especially careful in wooded areas where power lines may not be as visible.
- Do not load the gun until you are ready to shoot.
- Always keep your fingers away from the trigger & muzzle during cocking and handling.
- Do not walk, run or jump when carrying a loaded or cocked air gun. A loaded or a

cocked gun should never be carried inside a vehicle, house, camp or public place. Never climb a tree or fence or jump a ditch with a loaded gun. In such a case, first unload it and hand the gun to a friend or place it on the ground on the other side of the obstacle before crossing yourself.

- When transporting the gun, keep it unloaded and 'on safe'.
- Always keep the gun 'on safe' until you are ready to shoot even if the gun is unloaded.
- Do not put the gun away loaded and unattended.
- Always check to see if the gun is 'on safe' and unloaded when getting it from another person or from storage.
- Always keep the air gun and/or pellets out of the reach of children. Keep the air gun and pellets in separate places, better if under lock and key.
- Do not attempt to disassemble or tamper with your gun. Use a competent gunsmith. Many air guns contain powerful springs or high pressure air cylinders which can cause serious injury if released in an uncontrolled manner.
- Always handle and treat your gun as though it were loaded.
- Improper use or handling of air guns is not the responsibility of the manufacturer or distributor, under any circumstances. The user is responsible for any harm, which may be caused.
- Think first, fire second. Don't rely on any mechanical safety. Half safe is not safe.
- Be safe not sorry. Respect other's property.
- Air guns should never be used under the influences of alcohol or drugs.
- Do not brandish or display this product in public – it could confuse people and may be a crime.
- Do not change the coloration and markings to make it look more like a firearm.



Serious. Solid. Impact.

HATSAN

ARMS COMPANY

Kemalpasa O.S.B. Mah. Ansizca Sanayi Sitesi No: 303 Ic Kapi No: 1, 35170

Kemalpasa - Izmir - TURKEY

Tel: +90 (232) 878 91 00 • Fax: +90 (232) 878 91 02

www.hatsan.com.tr info@hatsan.com.tr