

# Sage® by Heston Blumenthal®

**Freephone (UK Landline):** 0808 178 1650  
**Mobile Calls (National Rate):** 0333 0142 970

**[www.sageappliances.co.uk](http://www.sageappliances.co.uk)**  
**[customerservice@sageappliances.co.uk](mailto:customerservice@sageappliances.co.uk)**

## **Register your product and get more from your purchase**

Product registration takes only a few minutes and ensures a record of your purchase. Registration also makes it easier to get support and advice on any questions or issues that you might have in the future. If you wish, we can also send you free recipes and additional hints and tips on making the best of your appliance.

➤ Go to [www.sageappliances.co.uk](http://www.sageappliances.co.uk) and click on 'Product Registration'.

## **What's on your mind?**

Our constant aim is to improve the quality and features of our appliances. We welcome your comments and ideas in assisting our ongoing development.

➤ Go to [www.sageappliances.co.uk](http://www.sageappliances.co.uk) and click on 'Support'.

**Sage®** by heston  
blumenthal®

Registered in England & Wales No. 8223512. Due to continued product improvement, the products illustrated or photographed in this document may vary slightly from the actual product.

Copyright BRG Appliances 2016.

BES870 UK - O16

# *the Barista Express™*

Instruction Book - BES870



**Sage**® by heston  
blumenthal™



## Contents

- 2 Sage Recommends Safety First
- 8 Components
- 11 Functions
- 25 Care & Cleaning
- 31 Troubleshooting
- 36 Coffees to try

## SAGE RECOMMENDS SAFETY FIRST

At Sage® by Heston Blumenthal® we are very safety conscious. We design and manufacture consumer products with the safety of you, our valued customer, foremost in mind. In addition we ask that you exercise a degree of care when using any electrical appliance and adhere to the following precautions.

## IMPORTANT SAFEGUARDS

### READ ALL INSTRUCTIONS BEFORE USE AND SAVE FOR FUTURE REFERENCE

- Before using for the first time please ensure that your electricity supply is the same as shown on the rating label on the underside of the appliance. If you have any concerns please contact your local electricity company.
- Your Sage® by Heston Blumenthal® appliance includes a BS 13 amp moulded mains plug on the supply cord.
- Should you need to change this plug, please complete the rewiring as follows (after safe disposal of the moulded plug).
- Please note that a cut off plug inserted into a socket is a serious danger risk.

- Wires are coloured as follows:
  - Blue = Neutral
  - Brown = Live
  - Green & Yellow = Earth
- As the colours of the wire may not correspond with the coloured markings which identify the terminals in your plug, please refer to the following:
  - The Blue wire must be connected to the terminal which is marked 'N'.
  - The Brown wire must be connected to the terminal which is marked with the letter 'L'.
  - The Green & Yellow wire must be connected to the terminal which is marked with the letter E or the earth symbol  $\perp$ .
- Please note that if a 13 amp plug is used, a 13 amp fuse should be used.
- To eliminate a choking hazard for young children, remove and safely discard the protective cover fitted to the power plug of this appliance.
- Do not place the Barista Express™ near the edge of a bench or table during operation. Ensure the surface is level, clean and free of water and other substances.
- Do not use the Barista Express™ on a sink drain board.
- Do not place the Barista Express™ on or near a hot gas or electric burner, or where it could touch a heated oven.
- Always ensure the Barista Express™ is properly assembled before connecting to power outlet and operating. Follow the instructions provided in this book.

- The appliance is not intended to be operated by means of an external timer or separate remote control system.
- Do not use attachments other than those provided with the Barista Express™.
- Do not attempt to operate the Barista Express™ by any method other than those described in this book.
- Do not operate the grinder without the hopper lid in position. Keep fingers, hands, hair, clothing and utensils away from the hopper during operation.
- Use only cold, tap water in the water tank. Do not use any other liquid.
- Never use the Barista Express™ without water in the water tank.
- Ensure the portafilter is firmly inserted and secured into the brewing head before using the machine.
- Never remove the portafilter during the brewing operation as the machine is under pressure.
- Do not move the Barista Express™ whilst in operation.
- Do not leave the Barista Express™ unattended when in use.
- Do not touch hot surfaces. Allow the Barista Express™ to cool down before moving or cleaning any parts.
- Do not place anything, other than cups for warming, on top of the Barista Express™.
- Always switch off the Barista Express™ by pressing the POWER button to 'Off', switch off at the power outlet and unplug if appliance is to be left unattended, if not in use, before cleaning, before attempting to move the appliance, disassembling,

assembling and when storing the appliance.

- This appliance shall not be used by children. Keep the appliance and its cord out of reach of children. Appliances can be used by persons with reduced physical, sensory or mental capabilities or lack of experience and knowledge if they have been given supervision or instruction concerning use of the appliance in a safe way and if they understand the hazards involved.
- Keep the appliance and accessories clean. Follow the cleaning instructions provided in this book.

## IMPORTANT SAFEGUARDS FOR ALL ELECTRICAL APPLIANCES

- Unwind the power cord fully before use.
- Do not let the power cord hang over the edge of a bench or table, touch hot surfaces, or become knotted.
- To protect against electric shock do not immerse power cord, power plug or appliance in water or any other substance.
- This appliance is not intended for use by persons (including children) with reduced physical, sensory or mental capabilities, or lack of experience or knowledge, unless they have been given supervision or instruction concerning use of the appliance by a person responsible for their safety.

- Children should be supervised to ensure they do not play with the appliance.
- It is recommended to regularly inspect the appliance. Do not use the appliance if power cord, power plug or appliance becomes damaged in any way. If damaged or maintenance other than cleaning is required, please contact Sage Customer Service on **0808 178 1650** | **0333 0142 970** or go to **sageappliances.co.uk**.
- Any maintenance, other than cleaning, should be performed at an authorised Sage Service Centre.
- This appliance is recommended for household use only.

Do not use this appliance for anything other than its intended use.

Do not use in moving vehicles or boats. Do not use outdoors. Misuse may cause injury.

- The installation of a residual current device (safety switch) is recommended to provide additional safety protection when using electrical appliances. It is advisable that a safety switch with a rated residual operating current not exceeding 30mA be installed in the electrical circuit supplying the appliance. See your electrician for professional advice.



## WARNING

Fully unwind the cord before use.



The symbol shown indicates that this appliance should not be disposed of in normal household waste. It should be taken to a local authority waste collection centre designated for this purpose or to a dealer providing this service. For more information, please contact your local council office.

**SAVE THESE INSTRUCTIONS**





## Components



- A. **450g bean hopper**  
With locking system for easy removal, storage and transfer of coffee beans.
- B. **Integrated conical burr grinder**
- G. **Grind outlet**
- F. **GRIND SIZE selector**  
Espresso grind settings from fine to coarse.
- G. **GRIND AMOUNT dial**  
Adjust the amount of fresh ground coffee dosed into the filter basket to suit the fineness or coarseness of the grind.
- H. **FILTER SIZE button**  
Tell the machine if you are using a 1 CUP or 2 CUP filter basket and the grinder will dispense the required amount of ground coffee for a single or double cup dose.
- I. **POWER button**
- J. **Integrated removable 54mm tamper**
- K. **Group head**
- L. **54mm stainless steel portafilter**  
With commercial style spouts.
- M. **Extra-tall cup clearance for tall mugs**
- N. **Removable wet & dry coffee separator drip tray**  
With Empty Me! full tray indicator.
- O. **Storage tray (located behind drip tray)**  
Houses accessories when not in use.
- P. **360° swivel-action steam wand**
- Q. **Dedicated hot water outlet**
- R. **Steam/Hot Water dial**  
Selector dial for steam and hot water.

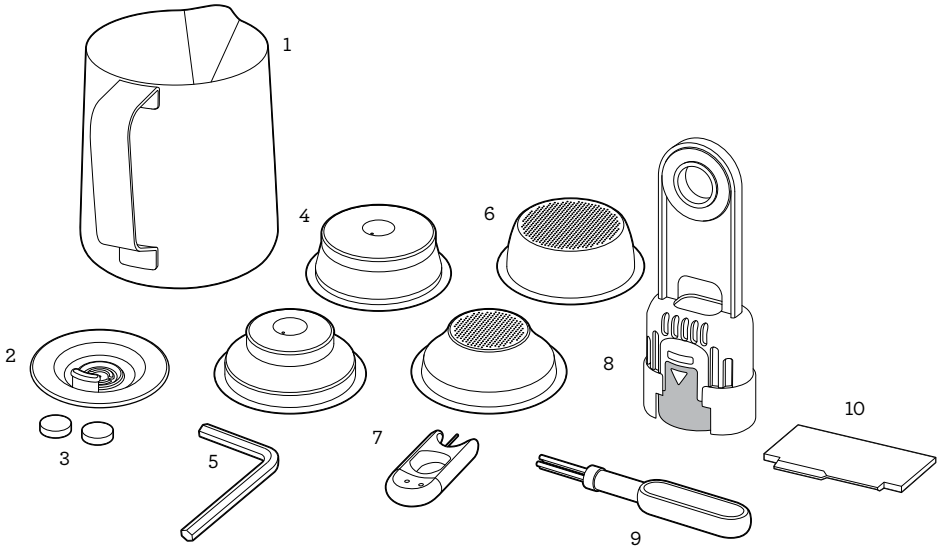

- S. **Steam/Hot Water light**  
Illuminates to indicate that the steam or hot water function is selected.
- T. **1 CUP and 2 CUP buttons**  
With preset, manual over-ride or programmable shot volumes.
- U. **CLEAN ME light**  
Illuminates when a cleaning cycle is required.
- V. **Espresso pressure gauge**
- W. **Programme me button**  
Re-programs the preset 1 CUP and 2 CUP shot volumes.
- X. **Cup warming tray**
- Y. **(2L) removable water tank**  
With replaceable water filter to reduce impurities and scale.

## ACCESSORIES

- 1. **Stainless steel milk jug**
- 2. **Cleaning disc**
- 3. **Cleaning tablets**
- 4. **Dual Wall filter baskets**  
(1 cup & 2 cup) Use with pre-ground coffee.
- 5. **Allen key**
- 6. **Single Wall filter baskets**  
(1 cup & 2 cup) Use when grinding fresh whole coffee beans.
- 7. **Cleaning tool**
- 8. **Water filter holder and filter**
- 9. **Cleaning brush**
- 10. **The Razor™ precision dose trimming tool**

## **INTEGRATED CONICAL BURR GRINDER**

Stainless steel conical burrs maximise ground coffee surface area for a full espresso flavour. Upper and lower burrs are removable for cleaning.

## **ADJUSTABLE GRIND SIZE**

Espresso grind settings from fine to coarse for optimal extraction..

## **ADJUSTABLE GRIND AMOUNT**

Adjust the amount of fresh ground coffee dosed into the filter basket to suit the fineness or coarseness of the grind.

## **AUTOMATIC DOSING**

Use the FILTER SIZE button to tell the machine if you are using a 1 CUP or 2 CUP filter basket. The grinder will dispense the required amount of ground coffee for a single or double cup dose.

## **HANDS FREE GRINDING**

Auto stop for hands free grinding directly into the portafilter.

## **THE RAZOR™ DOSE TRIMMING TOOL**

Patented twist blade trims down the puck to the right level for precision dosing and a consistent extraction.

## **ADJUSTABLE TEMPERATURE CONTROL**

For optimum coffee flavour.

## **PID TEMPERATURE CONTROL**

Electronic PID temperature control for increased temperature stability.

## **AUTO PURGE**

Automatically adjusts water temperature after steam for optimal espresso extraction temperature.

## **THERMOCOIL HEATING SYSTEM**

Integrated stainless steel water coil accurately controls water temperature.

## **COMMERCIAL STYLE STEAM WAND**

Stainless steel 360° swivel-action steam wand for effortless milk texturing.

## **INSTANT HOT WATER**

Dedicated hot water outlet for making Long blacks and pre-heating cups.

## **LOW PRESSURE PRE-INFUSION**

Applies low water pressure at the start of the extraction to gently expand grinds for an even extraction.

## **ESPRESSO PRESSURE GAUGE**

Monitors espresso extraction pressure.

## **VOLUMETRIC CONTROL**

Preset 1 & 2 cup volumes, manual over-ride or programmable shot volumes.

## **DRY PUCK FEATURE**

Removes excess water from the ground coffee in the filter basket after extraction for easy disposal of the coffee puck.



# Functions

## BEFORE FIRST USE

### Machine Preparation

Remove and discard all labelling and packaging materials attached to your espresso machine. Ensure you have removed all parts and accessories before discarding the packaging.

Remove the water tank located at the back of the machine by lifting the water tank handle. Remove the plastic bag containing the water filter and water filter holder. Clean parts and accessories (water tank, portafilter, filter baskets, milk jug) using warm water and a gentle dish washing liquid, then rinse and dry thoroughly. Wipe the outer housing, bean hopper and drip tray with a soft damp cloth and dry thoroughly. Do not immerse the outer housing, power cord or power plug in water or any other liquid.



### NOTE

All parts should be cleaned by hand using warm water and a gentle dish washing liquid. Do not use abrasive cleansers, pads or cloths which can scratch the surface. Do not clean any of the parts or accessories in the dishwasher.

## CONDITIONING THE WATER FILTER

- Remove the water filter and water filter holder from the plastic bag.
- Soak the water filter in a cup of water for 5 minutes, then rinse under cold running water.
- Wash the water filter holder with cold water, taking specific care to rinse the stainless steel mesh.
- Insert the water filter into the two parts of the water filter holder.
- Set Date Dial 2 months ahead.
- To install the assembled water filter holder into the water tank, align the base of the water filter holder with the adapter inside the water tank. Push down to lock into place.
- Slide the water tank back into position at the back of the machine, ensuring to push down completely to lock into place.



### NOTE

Change filters every 2 months. To purchase filters contact Sage Customer Service Centre UK Phone: 0808 178 1650 or visit [www.sageappliances.co.uk](http://www.sageappliances.co.uk)

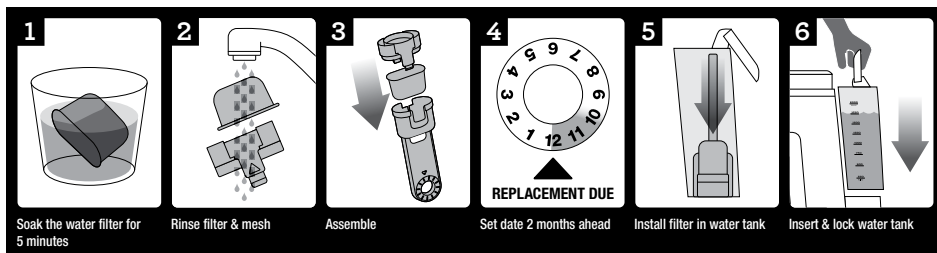

## FIRST USE

### Initial Start Up

- Ensure the water filter is securely fitted inside the water tank.
- Fill the water tank with cold, preferably filtered water up to the MAX mark. When replacing the water tank, ensure to push down completely to lock into place.



### NOTE

Always check the water level before use and replace water daily. We recommend using cold, filtered water. We do not recommend the use of de-mineralised or distilled water or any other liquid as this may affect the taste of the espresso and how the machine is designed to function.

- Ensure the hopper is locked into position.
- Plug the power cord into a 230V power outlet.
- Press the POWER button to switch the machine on. The POWER button light will flash while the machine is heating.



### NOTE

If the hopper is not correctly locked into position, the FILTER SIZE LED's will flash.

- A pumping sound will be heard. This is normal.
- When the machine has reached the correct operating temperature, the POWER button light will stop flashing and all button lights on the control panel will illuminate. The machine is now in STANDBY mode, ready for the next step 'Flushing The Machine'.

## Flushing the Machine

It is recommended to complete a water flushing operation, without ground coffee, to ensure the machine has been conditioned.

When the machine has reached STANDBY mode, follow these steps:

1. Press 2 CUP button to run hot water through the group head.
2. Position the steam wand tip over the drip tray. Rotate the STEAM/HOT WATER dial to the STEAM position and run steam through the steam wand for 10 seconds.

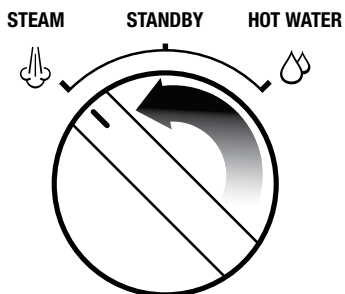

3. Rotate the STEAM/HOT WATER dial to the HOT WATER position and run water through the hot water outlet for 10 seconds.

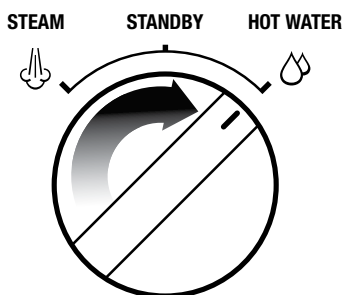

4. Repeat steps 1-3 until the water tank is empty.

## GENERAL OPERATION

### Setting the Grind Size

The grind size will affect the rate of water flow through the coffee in the filter basket and the flavour of the espresso. When setting the grind size, it should be fine but not too fine and powdery.

There are numbered settings on the GRIND SIZE selector. The smaller the number, the finer the grind size. The larger the number, the coarser the grind size.

We recommend you start at setting 8 and adjust as required.

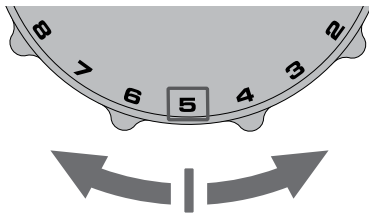

### Setting the Grind Amount

Set the GRIND AMOUNT dial to the 3 o'clock position as a starting point. Adjust towards LESS or MORE as required to adjust the dose amount. The metal cap on the supplied tamper should be level with the top edge of the filter basket rim, AFTER tamping.

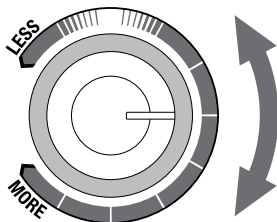

### TIPS

It is normal that the GRIND SIZE selector and GRIND AMOUNT dial will need to be adjusted a few times to achieve the correct extraction rate. Start with the suggested settings, extract an espresso, then refer to the Extraction Guide, page 22, to determine what adjustments need to be made.

### Selecting the Filter Size

Insert either the 1 CUP or 2 CUP filter basket into the portafilter (see 'Selecting a Filter Basket', page 20). Press the FILTER SIZE button to select SINGLE if using the 1 CUP filter basket, or DOUBLE if using the 2 CUP filter basket.

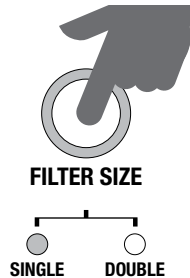

### Automatic Dosing

- Ensure the hopper is locked into position and is filled with fresh coffee beans.
- Ensure the filter basket is completely dry before placing the portafilter into the grinding cradle.
- Push and release the portafilter to engage the grinding activation switch, then allow fresh ground coffee to fill the portafilter.
- Grinding will automatically stop, however if you wish to stop grinding before the cycle has finished, push and release the portafilter.



### NOTE

It is normal for the portafilter to appear overfilled with ground coffee. Untamped coffee is three times the volume of tamped coffee.

### Manual Dosing

- If you prefer to manually dose, with the portafilter inserted in the grinding cradle, push and hold the portafilter to engage the grinding activation switch. Continue holding until the desired amount of ground coffee has been dosed.
- To stop grinding, release the portafilter. This will release the grinding activation switch and stop the grinding function.

## Tamping the Ground Coffee

- Once grinding is complete, carefully withdraw the portafilter from the grinding cradle.
- Tap the portafilter several times to collapse and distribute the coffee evenly in the filter basket.
- Tamp down firmly using approx. 30-40lbs (15-20kgs) of pressure. The amount of pressure is not as important as consistent pressure every time.
- As a guide to dose, the top edge of the metal cap on the tamper should be level with the top of the filter basket AFTER the coffee has been tamped.

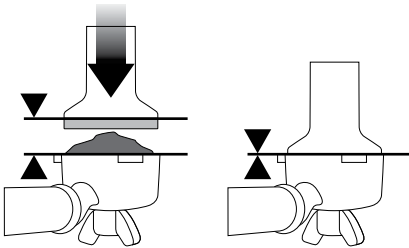

## Trimming The Dose

The Razor™ precision dose trimming tool allows you to trim the puck to the right level for a consistent extraction.



- Insert the Razor™ dose trimming tool into the filter basket until the shoulders of the tool rest on the rim of the basket. The blade of the dose trimming tool should penetrate the surface of the tamped coffee.
- Rotate the Razor™ dose trimming tool back and forth while holding the portafilter on an angle over a knock box to trim off excess coffee grinds. Your filter basket is now dosed with the correct amount of coffee.

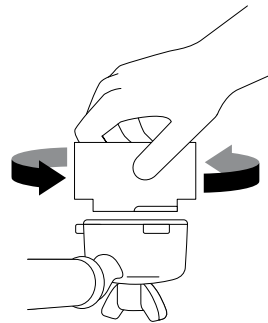

- Wipe excess coffee from the rim of the filter basket to ensure a proper seal is achieved in the group head.

## Purging the Group Head

Before placing the portafilter into the group head, run a short flow of water through the group head by pressing the 1 CUP button. This will stabilise the temperature prior to extraction.

## Inserting the Portafilter

Place the portafilter underneath the group head so that the handle is aligned with the INSERT position. Insert the portafilter into the group head and rotate the handle towards the centre until resistance is felt.

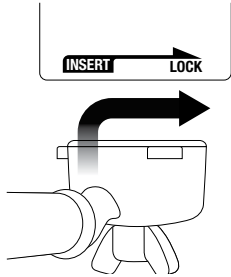

## Preset Shot Volume - 1 CUP button

Press the 1 CUP button once to extract a single shot of espresso at the preset volume (approx. 30ml). The extraction will start using the low pressure pre-infusion (see page 16). The machine will stop after the preset volume has been extracted.

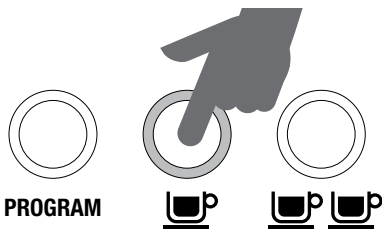

## NOTE

The amount of espresso extracted in the cup will vary depending on your grind size and grind amount settings.

Pressing the 1 CUP or 2 CUP button during a preset shot volume will immediately stop the extraction.

## Preset Shot Volume - 2 CUP button

Press the 2 CUP button once to extract a double shot of espresso at the preset volume (approx. 60ml). The extraction will start using the low pressure pre-infusion. The machine will stop after the preset volume has been extracted.

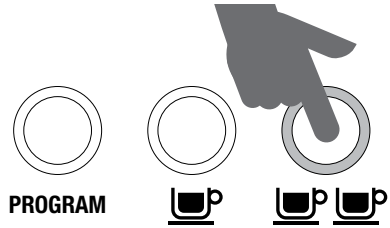

## Re-Programming Shot Volume - 1 CUP Button

1. To begin programming, press the Programme button once. The machine will beep once and the Programme button will begin to flash. This indicates the machine is in programming mode.
2. Press 1 CUP button to start espresso extraction. Press 1 CUP button again once desired volume of espresso has been extracted. The machine will beep twice to indicate the new 1 CUP volume has been set.

## Re-Programming Shot Volume - 2 CUP Button

1. To begin programming, press the Programme button once. The machine will beep once and the Programme button will begin to flash. This indicates the machine is in programming mode.
2. Press 2 CUP button to start espresso extraction. Press 2 CUP button again once desired volume of espresso has been extracted. The machine will beep twice to indicate the new 2 CUP volume has been set.



## Resetting Default Volumes

To reset the machine to the default 1 CUP and 2 CUP shot volumes, press and hold the PROGRAM button until the machine beeps three times. Release the PROGRAM button. The machine will return to its original default volume settings and default espresso water temperature (see 'Advanced Temperature Mode', page 18).



### NOTE

Default settings: 1 CUP shot volume is approx. 30ml. 2 CUP shot volume is approx. 60ml.

## Manual Shot Volume

Manually control low pressure pre-infusion time and shot volume without re-programming the preset shot volume.

Press and hold the 1 CUP or 2 CUP button.

The extraction will enter low pressure pre-infusion until the button is released.

When the 1 CUP or 2 CUP button is released, extraction will continue at full pressure. Press the 1 CUP or 2 CUP button again once the desired volume of espresso has been extracted.

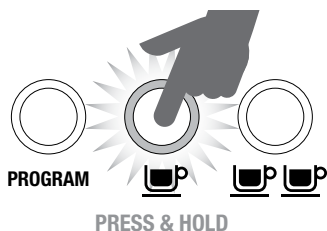

### NOTE

For optimal flavour when using a 1 CUP filter basket, you should extract approx. 30ml.

When using a 2 CUP filter basket, you should extract approx. 60ml.

## ESPRESSO PRESSURE GAUGE

### Low Pressure Pre-Infusion

The gauge needle will be positioned in the pre-infusion zone at the start of the extraction indicating the machine is in low pressure pre-infusion mode.

The low pressure pre-infusion gradually increases water pressure to gently expand grinds for an even extraction before increasing to full pressure.



### Ideal Espresso Zone

The gauge needle, when positioned anywhere within the solid grey zone during extraction, indicates the espresso has been extracted at the ideal pressure.



## Under Extracted Zone

The gauge needle, when positioned in the lower zone during extraction, indicates the espresso has been extracted with insufficient pressure.

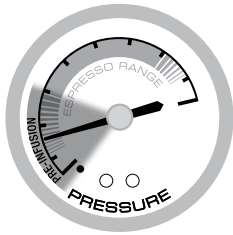

This occurs when the water flow through the ground coffee is too fast and results in an under extracted espresso that is watery and lacks crema and flavour.

Causes for under extraction include the grind being too coarse and/or insufficient coffee in the filter basket and/or under tamping.

## Over Extracted Zone

The gauge needle, when positioned in the upper zone during extraction, indicates the espresso has been extracted with too much pressure.

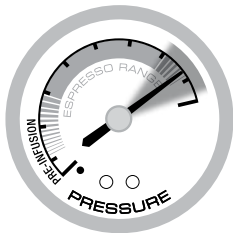

This occurs when the water flow through the ground coffee is too slow and results in an over extracted espresso that is very dark and bitter with a mottled and uneven crema.

Causes for over extraction include the grind being too fine and/or too much ground coffee in the filter basket and/or over tamping.

## USING THE STEAM/HOT WATER DIAL

### Steam

- Position the steam wand tip over the drip tray.
- Turn the STEAM/HOT WATER dial to the STEAM position. The STEAM/HOT WATER light will flash to indicate the machine is heating to create steam. During this time, condensed water may purge from the steam wand. This is normal.



### NOTE

When the machine creates steam, a pumping noise can be heard. This is the normal operation of the 15 bar Italian pump.

- When the STEAM/HOT WATER light stops flashing the steam wand is ready for use.
- Before inserting the wand into the milk, pause the steam by returning the dial back to the STANDBY position. Then within 8 seconds, insert the steam wand tip (1-2cm) below the surface of the milk, close to the right hand side of the jug at the 3 o'clock position and quickly turn the dial back to the STEAM position. Pausing the steam avoids the milk splashing out of the jug (this pause function lasts for 8 seconds only).
- Once the milk is at the correct temperature (60-65°C) and the jug is hot to touch, return the dial to the STANDBY position BEFORE removing the jug.

For more tips on milk texturing, refer to 'Texturing Milk', page 23.



### NOTE

After 5 minutes of continuous steaming, the machine will automatically disable the steam function. The STEAM/HOT WATER light will flash. When this occurs return the dial to the STANDBY position.

## Hot Water

- Turn the STEAM/HOT WATER dial to the HOT WATER position. The STEAM/HOT WATER light will flash to indicate the machine is heating to create hot water.
- When the STEAM/HOT WATER light stops flashing the hot water is up to temperature. Hot water will pour from the hot water outlet and can be used for making long blacks and pre-heating cups.
- To stop the hot water, return the dial to the STANDBY position.

## AUTO PURGE

For extracting espresso immediately after using the steam function, this machine features an auto purge function.

The auto purge function ensures the ground coffee will not be burnt by the initial water flow from the thermocoil being too hot. The initial water is automatically released into the drip tray after steaming to ensure the thermocoil is at the optimal temperature for extracting espresso.

Your espresso will always be extracted at the optimal temperature ensuring only the best flavours are extracted.



### TIPS

Water is automatically released into the drip tray after the steam to ensure the thermocoil is at the optimal temperature for extracting espresso. This is normal. If you find water around the front of the machine, ensure the drip tray is firmly pushed in place after using the steam and hot water functions.

## ADVANCED TEMPERATURE MODE

### 1. Adjusting Water Temperature

Different beans require a different water temperature to extract their optimum flavour.

The Barista Express™ allows you to adjust water temperature  $\pm 2^{\circ}\text{C}$  in  $1^{\circ}\text{C}$  increments from the default temperature.

To enter Advanced Temperature Mode:

1. Press the POWER button to switch the machine off.
2. Press & hold the PROGRAM button, then press the POWER button. The machine will beep once. The illuminated button will indicate the current temperature selected. To adjust the water temperature, press one of the following buttons within 5 seconds of entering Advanced Temperature Mode. The machine will beep twice to confirm the change. If no buttons are pressed within 5 seconds after entering Advanced Temperature Mode, no change will be made & the machine will return to STANDBY mode.

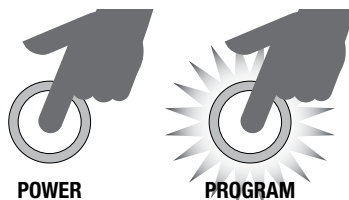

### 2. Default Temperature setting:

In Advanced Temperature Mode, press the Programme ME button.

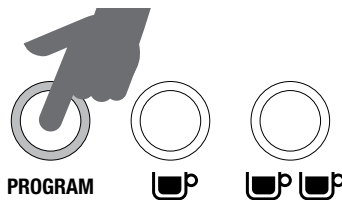

### 3. Increase Water Temperature +1°C:

In Advanced Temperature Mode, press the 1 CUP button.

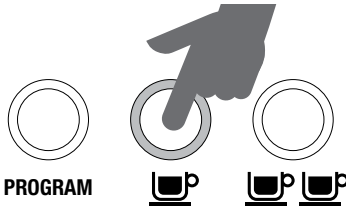

### 4. Increase Water Temperature +2°C:

In Advanced Temperature Mode, press the 2 CUP button.

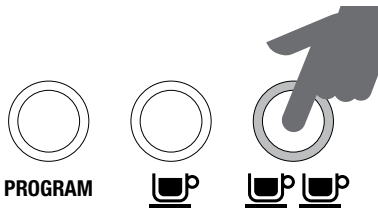

### 5. Decrease Water Temperature -1°C:

In Advanced Temperature Mode, press the FILTER SIZE button.

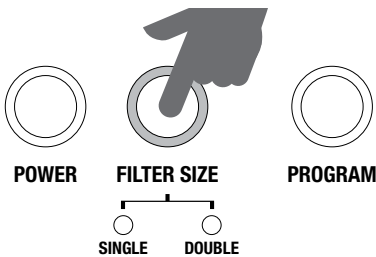

### 6. Decrease Water Temperature -2°C:

In Advanced Temperature Mode, press the POWER button.

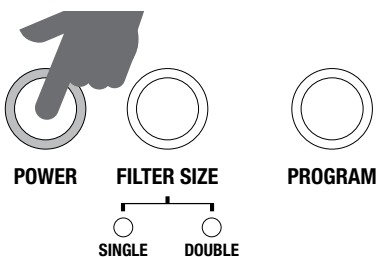

## PRE-HEATING

### Heating your cup or glass

A warm cup will help maintain the coffee's optimal temperature. Pre-heat your cup by rinsing with hot water from the hot water outlet and place on the cup warming tray.

### Heating the portafilter and filter basket

A cold portafilter and filter basket can reduce the extraction temperature enough to significantly affect the quality of your espresso. Always ensure the portafilter and filter basket are pre-heated with hot water from the hot water outlet before initial use.



### NOTE

Always wipe the portafilter and filter basket dry before dosing with ground coffee as moisture can encourage channelling where water can by-passes the ground coffee during extraction.

## SELECTING A FILTER BASKET

### Single Wall Filter Baskets

Use Single Wall filter baskets if grinding fresh whole coffee beans.

Single Wall filter baskets allow you to experiment with grind, dose and tamp to create a more balanced espresso.

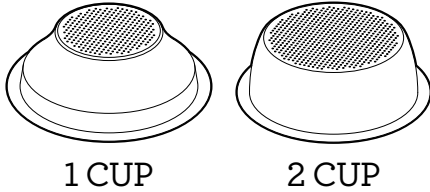

### Dual Wall Filter Baskets

Use Dual Wall filter baskets if using pre-ground coffee.

Dual Wall filter baskets regulate the pressure and help to optimise the extraction regardless of the grind, dose, tamp pressure or freshness.

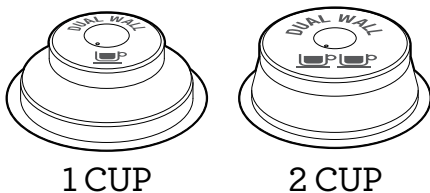

### NOTE

Regardless of whether you use Single Wall or Dual Wall filter baskets, use the 1 CUP basket when brewing a single cup and the 2 CUP basket when brewing two cups or a stronger single cup or mug.

The provided filter baskets are designed for:

1 CUP basket = approx. 8-10g.

If using pre-ground coffee, this is approx. 2 level tablespoons.

2 CUP basket = approx. 15-18g.

If using pre-ground coffee, this is approx. 3 level tablespoons. If using freshly ground coffee, this is approx. 4 level tablespoons.

The reason for this difference is that pre-ground coffee is often coarser and hence occupies more volume than coffee that is more finely ground.

### NOTE

You may need to experiment with how much coffee is dosed into the filter basket or how long the grinder needs to run to achieve the correct amount. For example, when using a finer espresso grind with the Single Wall filter baskets, you may need to increase the grind amount to ensure the filter basket is correctly dosed.

### NOTE

You will need to adjust the grind amount and size if switching from a single basket to a double basket, or vice versa.

## THE GRIND

If grinding coffee beans, the grind size should be fine but not too fine. The grind size will affect the rate at which the water flows through the ground coffee in the filter basket and the taste of the espresso.

If the grind is too fine (looks like powder and feels like flour when rubbed between fingers), the water will not flow through the coffee even when under pressure. The resulting espresso will be **OVER EXTRACTED**, dark in colour and bitter in flavour.

If the grind is too coarse the water will flow through the ground coffee in the filter basket too quickly. The resulting espresso will be **UNDER EXTRACTED** and lacking in colour and flavour.

## COFFEE DOSE AND TAMPING

Follow the instructions for:

1. Setting the Grind Size, page 13.
2. Setting the Grind Amount, page 13.
3. Selecting the Filter Size, page 13.
4. Automatic Dosing or Manual Dosing, page 13.
5. Tamping the Ground Coffee, page 14.
6. Trimming the Dose, page 14.

## PURGING THE GROUP HEAD

Before placing the portafilter into the group head, run a short flow of water through the group head by pressing the 1 CUP button. This will purge any ground coffee residue from the group head and stabilise the temperature prior to extraction.

## INSERTING THE PORTAFILTER

Place the portafilter underneath the group head so that the handle is aligned with the **INSERT** position. Insert the portafilter into the group head and rotate the handle towards the centre until resistance is felt.

## EXTRACTING ESPRESSO

- Place pre-warmed cup(s) beneath the portafilter and press the 1 CUP or 2 CUP button for the desired volume.
- Due to pre-infusion time, the espresso will not start to flow immediately.
- As a guide, the espresso will start to flow after 4–7 seconds (infusion time) and should be the consistency of dripping honey.
- If the espresso starts to flow after less than 3 seconds you have either under dosed the filter basket and/or the grind is too coarse. This is an **UNDER-EXTRACTED** shot.
- If the espresso starts to drip but doesn't flow after 8 seconds, then you have either over dosed the filter basket and/or the grind is too fine. This is an **OVER-EXTRACTED** shot.

A great espresso is about achieving the perfect balance between sweetness, acidity and bitterness. The flavour of your coffee will depend on many factors, such as the type of coffee beans, degree of roast, freshness, coarseness or fineness of the grind, dose of ground coffee, and tamping pressure.

Experiment by adjusting these factors just one at a time to achieve the taste of your preference, see 'Extraction Guide,' page 22.

# Extraction Guide

### CORRECT EXTRACTION



✓  
Within Espresso Range



- Flow starts after 4–7 secs
- Flow slow like warm honey
- Crema is golden brown with a fine mousse texture
- Espresso is dark brown
- Extraction takes 25–35 secs

#### AFTER EXTRACTION



**REMOVE USED GRINDS**  
Used grinds will form a coffee 'puck'. If the puck is wet, refer to the 'Under Extraction' section.



**RINSE FILTER BASKET**  
Keep the filter basket clean to prevent blockages. Without ground coffee in the filter basket, lock the portafilter into the machine and run hot water through.

### UNDER EXTRACTION



✗  
Under Espresso Range

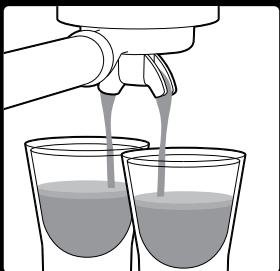

- Flow starts after 1–3 secs
- Flow fast like water
- Crema is thin and pale
- Espresso is pale brown
- Tastes bitter/sharp, weak and watery
- Extraction takes up to 20 secs

#### SOLUTIONS



**GRIND SIZE FINER**  
Adjust & re-test

**Grind Finer**  
Tamp using 30-40lbs of pressure. The top edge of metal cap on the tamper should be level with the top of the filter basket AFTER tamping.  
Trim the puck to the right level using the Razor™ dose trimming tool.

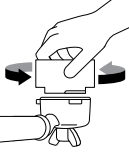

Always use the Razor™ tool and trim off some coffee after tamping.

### OVER EXTRACTION



✗  
Over Espresso Range



- Flow starts after 8 secs
- Flow drips or not at all
- Crema is dark and spotty
- Espresso is very dark brown
- Tastes bitter and burnt
- Extraction takes more than 40 secs

#### SOLUTIONS

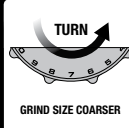

**GRIND SIZE COARSER**  
Adjust & re-test

**Grind Coarser**  
Tamp using 15 kilos of pressure. The top edge of metal cap on the tamper should be level with the top of the filter basket AFTER tamping.  
Trim the puck to the right level using the Razor™ dose trimming tool.

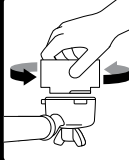

Always use the Razor™ tool and trim off some coffee after tamping.

	GRIND	GRIND DOSE	TAMP	SHOT TIME
<b>OVER EXTRACTED</b> BITTER • ASTRINGENT	TOO FINE	TOO MUCH	TOO HEAVY	OVER 40 SEC
<b>BALANCED</b>	OPTIMUM	10-12g (1 CUP) 18-20g (2 CUP)	15-20kg	25-35 SEC
<b>UNDER EXTRACTED</b> UNDERDEVELOPED • SOUR	TOO COARSE	TOO LITTLE	TOO LIGHT	UNDER 20 SEC

## ADJUSTING CONICAL BURRS

Some types of coffee may require a wider grind range to achieve an ideal extraction or brew. A feature of your Barista Express™ is the ability to extend this range with an adjustable upper burr. We recommend making only one adjustment at a time.



1  
Unlock hopper

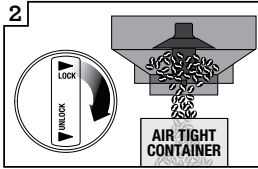

2  
Hold hopper over container & turn dial to release beans into container

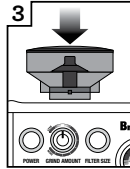

3  
Align hopper into position

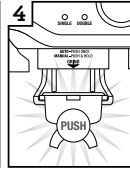

4  
Run grinder until empty

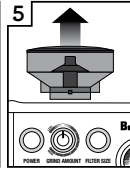

5  
Remove hopper



6  
Remove upper burr

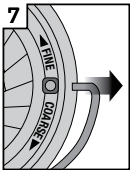

7  
Remove wire handle from both sides of the burr



8  
Move adjustable top burr, 1 number coarser or finer

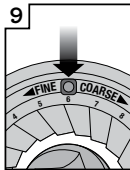

9  
Align the number with the handle opening

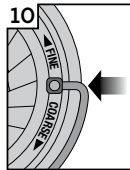

10  
Insert wire handle from both sides of the burr



11  
Push upper burr firmly into position



12  
Lock upper burr

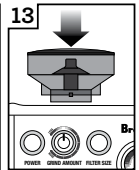

13  
Align hopper into position



14  
Lock hopper

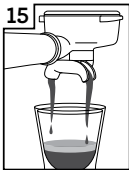

15  
Check your extraction



## TEXTURING MILK

There are two phases to texturing milk.

The first is stretching the milk to aerate it and the second is swirling the milk to make it silky smooth. These two operations should blend into one.

- Always start with fresh cold milk.
- Fill the jug just below the “V” at the bottom of the spout.
- Position the steam wand tip over the drip tray and turn the STEAM/HOT WATER dial to the STEAM position.
- The STEAM/HOT WATER light will flash to indicate the machine is heating to create steam. During this time, condensed water may purge from the steam wand. This is normal. When the STEAM/HOT WATER light stops flashing the steam wand is ready for use.



### NOTE

When the machine creates steam, a pumping noise can be heard. This is the normal operation of the 15 bar Italian pump.

- Before inserting the wand into the milk, pause the steam by returning the dial back to the STANDBY position. Then within 8 seconds, insert the steam wand tip  $\frac{1}{4}$ - $\frac{3}{4}$ ” (1-2cm) below the surface of the milk, close to the right hand side of the jug at the 3 o'clock position and quickly turn the dial back to the STEAM position. Pausing the steam avoids the milk splashing out of the jug (this pause function lasts for 8 seconds only).
- Keep the tip just under the surface of the milk until the milk is spinning clockwise, producing a vortex (whirlpool effect).
- With the milk spinning, slowly lower the jug. This will bring the steam tip to the surface of the milk & start to introduce air into the milk. You may have to gently break the surface of the milk with the tip to get the milk spinning fast enough.

- Keep the tip at or slightly below the surface, continuing to maintain the vortex. Texture the milk until sufficient volume is obtained.
- Lift the jug to lower the tip beneath the surface, but keep the vortex of milk spinning. The milk is at the correct temperature (60-65°C) when the jug is hot to touch.
- Turn off steam BEFORE taking the tip out of the milk.
- Set the jug to one side. Immediately wipe the steam wand with a damp cloth. Then, with the steam wand tip directed over the drip tray, briefly turn steam on to clear any remaining milk from inside the steam wand.
- Tap the jug on the bench to collapse any bubbles.
- Swirl the jug to “polish” and re-integrate the texture.
- Pour milk directly into the espresso.
- The key is to work quickly, before the milk begins to separate.



### TIPS

Water is automatically released into the drip tray after the steam and hot water functions to ensure the thermocoil is at the optimal temperature for extracting espresso. This is normal. If you find water around the front of the machine, ensure the drip tray is firmly pushed in place after using the steam and hot water functions.



### HINTS & TIPS

- Use freshly roasted coffee beans, with a ‘roasted on’ date and use within 2 weeks of ‘roasted on’ date.
- Grind beans immediately before brewing as ground coffee quickly loses its flavour and aroma.
- Store coffee beans in a cool, dark and dry container. Vacuum seal if possible.
- Buy coffee beans in small batches to reduce the storage time and store no more than one weeks supply at any time.



## Care & Cleaning

### REPLACING THE WATER FILTER

- The provided water filter helps prevent scale build-up in and on many of the inner functioning components. Replacing the water filter every two months will reduce the need to descale the machine.
- If you live in a hard water area, we recommend you change the water filter more frequently.
- Remove the new water filter from the plastic bag.
- Soak the new water filter in a cup of water for 5 minutes, then rinse under cold running water.
- Wash the water filter holder with cold water, taking specific care to rinse the stainless steel mesh.
- Insert the new water filter into the two parts of the water filter holder.
- Set Date Dial 2 months ahead.
- To install the assembled water filter holder into the water tank, align the base of the water filter holder with the adapter inside the water tank. Push down to lock into place.
- Slide the water tank back into position at the back of the machine, ensuring to push down completely to lock into place.

The water filter should be removed if using filtered or bottled water.



### NOTE

To purchase water filters contact Sage Customer Service on 0808 178 1650.

### CLEANING CYCLE

The CLEAN ME light will illuminate when a cleaning cycle is required. This is a back-flushing cycle and is separate from descaling.

1. Insert the 1 CUP filter basket into the portafilter, followed by the supplied cleaning disc, followed by 1 cleaning tablet.
2. Lock the portafilter into the group head and place a large container beneath the portafilter spouts.
3. Ensure the water tank is filled with cold water and the drip tray is empty.
4. Press the POWER button to switch the machine off.
5. Press the 1 CUP and 2 CUP buttons simultaneously, then also press the POWER button. Hold all 3 buttons together for approximately 10 seconds.
6. The cleaning cycle will commence and last for approximately 5 minutes. During this time, water will intermittently flow from the portafilter spouts. Once complete, 3 beeps will sound.
7. Remove the portafilter and ensure the tablet has completely dissolved. If the tablet has not dissolved, repeat until the tablet has dissolved.

## DESCALING

1. Ensure the machine is switched off.
2. Remove the filter holder.
3. Empty one Sage Descaler sachet (25g) into 1 litre of warm water, stir to dissolve. Pour solution into the water tank.
4. Remove the portafilter from the group head and place a large container beneath the group head and steam wand.
5. Press the POWER button to switch the machine on. When the brewing temperature has been reached and all the button lights on the control panel have illuminated, press and hold the 1 CUP button to commence a manual pour. Release the button once half the mixture of descale solution has run through the group head.
6. Set the STEAM/HOT WATER dial to the HOT WATER position and allow hot water to run through the hot water outlet for approximately 30 seconds. Return the dial back to the STANDBY position.
7. Set the STEAM/HOT WATER dial to the STEAM position and allow steam to run through the steam wand for approximately 2 minutes. Return the dial back to the STANDBY position.
8. If any of the solution remains in the water tank, press and hold the 1 CUP button to commence a manual pour. Release the button once the tank is empty and nothing runs through the group head.
9. After descaling, remove the water tank, rinse thoroughly then refill with fresh cold water. To rinse the machine, repeat steps 6–8.



### WARNING

Do not immerse power cord, power plug or appliance in water or any other liquid. The water tank should never be removed or completely emptied during descaling.

## CLEANING THE CONICAL BURR GRINDER

This grinder cleaning cycle removes oil build-up on the burrs which can impede performance.

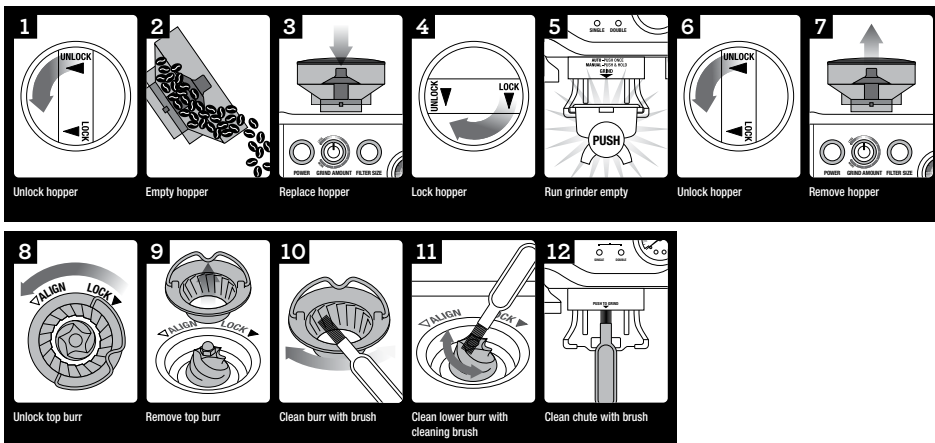

## ADVANCED CLEANING FOR THE CONICAL BURR GRINDER

This step is only required if there's a blockage between the grinding burrs and the grinder outlet.

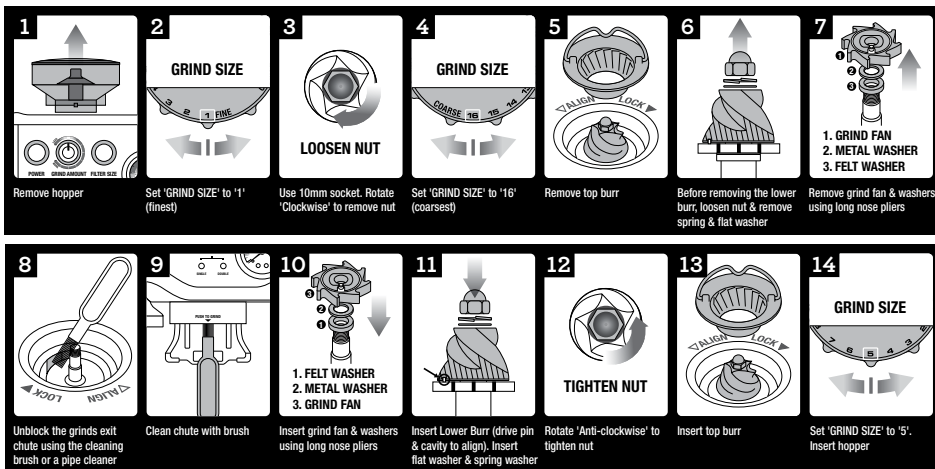

### WARNING

Care should be taken as the grinder burrs are extremely sharp.

## CLEANING THE STEAM WAND

The steam wand should always be cleaned after texturing milk.

- Wipe the steam wand with a damp cloth. Then with the steam wand tip directed over the drip tray, briefly set the STEAM/HOT WATER dial to the STEAM position. This will clear any remaining milk from inside the steam wand.
- If any of the holes in the tip of the steam wand become blocked, ensure the STEAM/HOT WATER dial is in the STANDBY

position. Press the POWER button to switch the machine off and allow to cool. Use the pin on the end of the provided cleaning tool to unblock the hole(s).

- If the steam wand remains blocked, remove the tip using the integrated spanner in the cleaning tool and soak in hot water. Use the pin on the end of the provided cleaning tool to unblock the hole(s) before re-attaching to the steam wand.

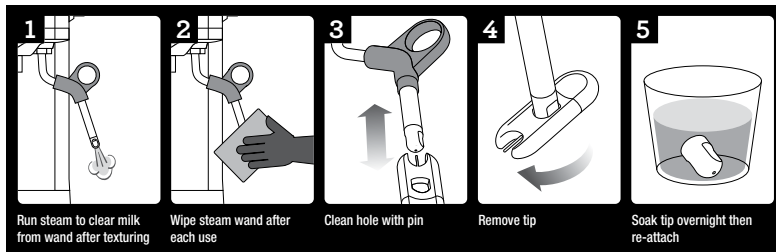

## CLEANING THE FILTER BASKETS AND PORTAFILTER

- The filter baskets and portafilter should be rinsed under hot water immediately after use to remove all residual coffee oils. If any of the holes in the filter basket become blocked, use the pin on the end of the provided cleaning tool to unblock the hole(s).

- If the hole(s) remain blocked, dissolve a cleaning tablet in hot water and soak filter basket and portafilter in solution for approx. 20 minutes. Rinse thoroughly.

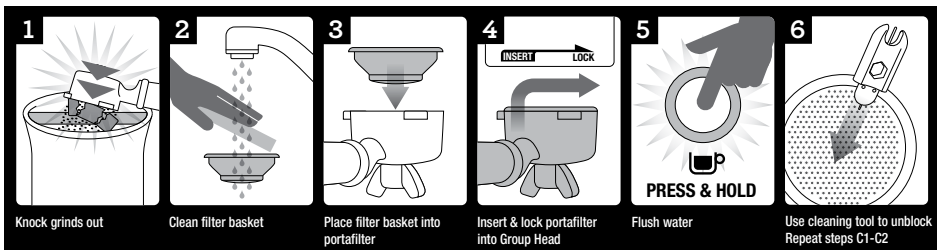

## CLEANING THE SHOWER SCREEN

- The group head interior and shower screen should be wiped with a damp cloth to remove any ground coffee particles.
- Periodically purge the machine. Place an empty filter basket and portafilter into the group head. Press and hold the 1 CUP button and run a short flow of water to rinse out any residual coffee.

## CLEANING THE DRIP & STORAGE TRAY

- The drip tray should be removed, emptied and cleaned at regular intervals, particularly when the drip tray full indicator is showing EMPTY ME!
- Remove the grid from the drip tray. Lift the coffee grind separator and dispose of any coffee grounds. The EMPTY ME! indicator can also be removed from the drip tray by pulling upwards to release the side latches. Wash all parts in warm soapy water with a soft cloth. Rinse and dry thoroughly.
- The storage tray (located behind the drip tray) can be removed and cleaned with a soft, damp cloth. Do not use abrasive cleansers, pads or cloths which can scratch the surface.



### NOTE

All parts should be cleaned by hand using warm water and a gentle dish washing liquid. Do not use abrasive cleansers, pads or cloths which can scratch the surface. Do not clean any of the parts or accessories in the dishwasher.

## CLEANING THE OUTER HOUSING & CUP WARMING TRAY

The outer housing and cup warming tray can be cleaned with a soft, damp cloth. Polish with a soft, dry cloth. Do not use abrasive cleansers, pads or cloths which can scratch the surface.

## STORING YOUR MACHINE

Before storing, ensure the STEAM/HOT WATER dial is in the STANDBY position, press the POWER button to switch the machine off and remove the plug from the power outlet. Remove unused beans from the hopper, clean the grinder (see page 26), empty the water tank and the drip tray.

Ensure the machine is cool, clean and dry.

Insert all accessories into the storage tray. Store upright. Do not place anything on top.



### WARNING

Do not immerse power cord, power plug or appliance in water or any other liquid.

## USING THE ALLEN KEY

Over time, the silicone seal surrounding the shower screen will need to be replaced to ensure optimum brewing performance.

1. Press the POWER button to switch the machine off and unplug the cord from the power outlet.
2. Carefully remove the water tank and drip tray, taking particular care if they are full.
3. Using a skewer or similar, clean the centre of the screw of any residual coffee.
4. Insert the shorter end of the Allen Key into the centre of the screw. Turn counter-clockwise to loosen the screw.

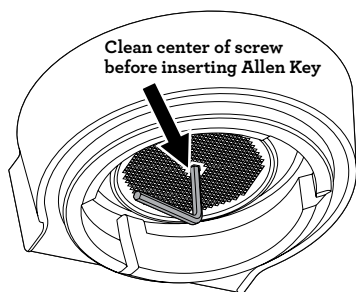

5. Once loosened, carefully remove and retain the screw, stainless steel shower screen and black dispersion plate. Make note of the side of the shower screen and dispersion plate that are facing downwards. This will make re-assembly easier. Wash the shower screen and dispersion plate in warm soapy water, then dry thoroughly.

6. Remove the silicone seal with your fingers or a pair of long-nose pliers. Insert the new seal, flat side first, so the ribbed side is facing you.

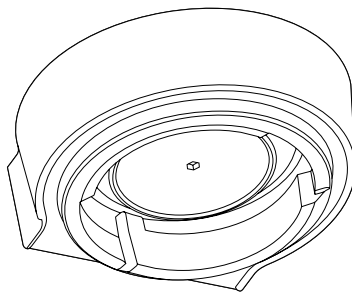

7. Re-insert the dispersion plate, then the shower screen, then the screw. With your fingers, turn the screw clockwise for 2-3 revolutions then insert the Allen Key to tighten until the screw is flush with the shower screen.
8. Re-insert the drip tray and water tank.

Contact Sage Customer Service or visit [www.sageappliances.co.uk](http://www.sageappliances.co.uk) for replacement silicone seals or for advice.



# Troubleshooting

PROBLEM	POSSIBLE CAUSES	EASY SOLUTION
<b>Machine does not heat up. STEAM/HOT WATER light flashes when the machine is turned on.</b>	<ul style="list-style-type: none"><li>• STEAM/HOT WATER dial is not in the STANDBY position.</li></ul>	<ul style="list-style-type: none"><li>• Turn the STEAM/HOT WATER dial to the STANDBY position. Machine will commence heating.</li></ul>
<b>Water does not flow from the group head. No hot water.</b>	<ul style="list-style-type: none"><li>• Machine has not reached operating temperature.</li></ul>	<ul style="list-style-type: none"><li>• Allow time for the machine to reach operating temperature. The POWER button light will stop flashing and all button lights on the control panel will illuminate when ready.</li></ul>
	<ul style="list-style-type: none"><li>• Water tank is empty.</li></ul>	<ul style="list-style-type: none"><li>• Fill tank.</li></ul>
	<ul style="list-style-type: none"><li>• Water tank is not fully inserted and locked into position.</li></ul>	<ul style="list-style-type: none"><li>• Push water tank down completely to lock into place.</li></ul>
	<ul style="list-style-type: none"><li>• Machine needs to be descaled.</li></ul>	<ul style="list-style-type: none"><li>• Refer to 'Descaling', page 25.</li></ul>
	<ul style="list-style-type: none"><li>• Coffee is ground too finely and/ or too much coffee in filter basket and/ or over tamping and/ or filter basket is blocked.</li></ul>	<ul style="list-style-type: none"><li>• See below, 'Espresso only drips from the portafilter spouts or not at all'.</li></ul>
<b>Espresso only drips from the portafilter spouts or not at all.</b>	<ul style="list-style-type: none"><li>• Coffee is ground too finely.</li></ul>	<ul style="list-style-type: none"><li>• Use slightly coarser grind. Refer to 'Setting the Grind Size', page 13 and 'Over Extraction', page 17.</li></ul>
	<ul style="list-style-type: none"><li>• Too much coffee in the filter basket.</li></ul>	<ul style="list-style-type: none"><li>• Lower dose of coffee. Refer to 'Setting the Grind Amount', page 13 and 'Over Extraction', page 17.</li></ul>
	<ul style="list-style-type: none"><li>• Coffee tamped too firmly.</li></ul>	<ul style="list-style-type: none"><li>• Tamp between 15–20kg of pressure.</li></ul>
	<ul style="list-style-type: none"><li>• Water tank is empty.</li></ul>	<ul style="list-style-type: none"><li>• Fill tank.</li></ul>
	<ul style="list-style-type: none"><li>• Water tank is not fully inserted and locked into position.</li></ul>	<ul style="list-style-type: none"><li>• Push water tank down completely to lock into place.</li></ul>
	<ul style="list-style-type: none"><li>• The filter basket may be blocked.</li></ul>	<ul style="list-style-type: none"><li>• Use the pin on the end of the provided cleaning tool to unblock the hole(s). If the hole(s) remain blocked, dissolve a cleaning tablet in hot water and soak filter basket and portafilter in solution for approx. 20 minutes. Rinse thoroughly.</li></ul>
	<ul style="list-style-type: none"><li>• Machine needs to be descaled.</li></ul>	<ul style="list-style-type: none"><li>• Refer to 'Descaling', page 25.</li></ul>



<b>PROBLEM</b>	<b>POSSIBLE CAUSES</b>	<b>EASY SOLUTION</b>
<b>Espresso runs out too quickly.</b>	<ul style="list-style-type: none"> <li>• Coffee is ground too coarsely.</li> </ul>	<ul style="list-style-type: none"> <li>• Use slightly finer grind. Refer to 'Setting the Grind Size', page 13 and 'Under Extraction', page 17.</li> </ul>
	<ul style="list-style-type: none"> <li>• Not enough coffee in the filter basket.</li> </ul>	<ul style="list-style-type: none"> <li>• Increase dose of coffee. Refer to 'Setting the Grind Amount', page 13 and 'Under Extraction', page 17.</li> </ul>
	<ul style="list-style-type: none"> <li>• Coffee tamped too lightly.</li> </ul>	<ul style="list-style-type: none"> <li>• Tamp between 15–20kg of pressure.</li> </ul>
<b>Espresso runs out around the edge of the portafilter.</b>	<ul style="list-style-type: none"> <li>• Portafilter not inserted in the group head correctly.</li> </ul>	<ul style="list-style-type: none"> <li>• Ensure portafilter is completely inserted and rotated until resistance is felt.</li> </ul>
	<ul style="list-style-type: none"> <li>• There are coffee grounds around the filter basket rim.</li> </ul>	<ul style="list-style-type: none"> <li>• Clean excess coffee from the rim of the filter basket to ensure a proper seal in group head.</li> </ul>
	<ul style="list-style-type: none"> <li>• Too much coffee in the filter basket.</li> </ul>	<ul style="list-style-type: none"> <li>• Lower dose of coffee. Refer to 'Setting the Grind Amount', page 13.</li> </ul>
	<ul style="list-style-type: none"> <li>• The silicone seal surrounding the shower screen needs to be replaced to ensure the portafilter is properly secured into the group head.</li> </ul>	<ul style="list-style-type: none"> <li>• Refer to 'Using the Allen Key', page 29.</li> </ul>
<b>No steam.</b>	<ul style="list-style-type: none"> <li>• Machine has not reached operating temperature.</li> </ul>	<ul style="list-style-type: none"> <li>• Allow time for the machine to reach operating temperature. The STEAM/HOT WATER light will flash to indicate the machine is heating to create steam. During this time, condensed water may purge from the steam wand. This is normal. When the STEAM/HOT WATER light stops flashing the steam wand is ready for use.</li> </ul>
	<ul style="list-style-type: none"> <li>• Water tank is empty.</li> </ul>	<ul style="list-style-type: none"> <li>• Fill tank.</li> </ul>
	<ul style="list-style-type: none"> <li>• Water tank is not fully inserted and locked into position.</li> </ul>	<ul style="list-style-type: none"> <li>• Push water tank down completely to lock into place.</li> </ul>
	<ul style="list-style-type: none"> <li>• Machine needs to be descaled.</li> </ul>	<ul style="list-style-type: none"> <li>• Refer to 'Descaling', page 25.</li> </ul>
	<ul style="list-style-type: none"> <li>• Steam wand is blocked.</li> </ul>	<ul style="list-style-type: none"> <li>• Refer to 'Cleaning the Steam Wand', page 27.</li> </ul>
	<ul style="list-style-type: none"> <li>• STEAM/HOT WATER dial is not in the STEAM position.</li> </ul>	<ul style="list-style-type: none"> <li>• Ensure the STEAM/HOT WATER dial is completely rotated to the STEAM position.</li> </ul>

<b>PROBLEM</b>	<b>POSSIBLE CAUSES</b>	<b>EASY SOLUTION</b>
<b>Coffee not hot enough.</b>	• Cups not pre-heated.	• Rinse cups under hot water outlet and place on cup warming tray.
	• Portafilter not pre-heated.	• Rinse portafilter under hot water outlet. Dry thoroughly.
	• Milk not hot enough (if making a cappuccino or latté etc).	• Heat milk until side of the jug becomes hot to touch.
	• Machine needs to be descaled.	• Refer to 'Descaling', page 25.
<b>No crema.</b>	• Coffee tamped too lightly.	• Tamp between 15-20kg of pressure.
	• Coffee is ground too coarsely.	• Use slightly finer grind. Refer to 'Setting the Grind Size', page 13 and 'Under Extraction', page 17.
	• Coffee beans or pre-ground coffee are not fresh.	• If grinding fresh whole coffee beans, buy freshly roasted coffee with a "roasted on" date and use within 2 weeks of this date. • If using pre-ground coffee, use within a week of grinding.
	• The filter basket may be blocked.	• Use the pin on the end of the provided cleaning tool to unblock the hole(s). If the hole(s) remain blocked, dissolve a cleaning tablet in hot water and soak filter basket and portafilter in solution for approx. 20 minutes. Rinse thoroughly.
	• Single Wall filter baskets are being used with pre-ground coffee.	• Ensure you use Dual Wall filter baskets with pre-ground coffee.
<b>Drip tray fills too quickly.</b>	• Auto purge feature. Water is automatically released into the drip tray after the steam and hot water functions to ensure the thermocoil is at the optimal temperature for extracting espresso.	• No action required as this is the normal operation of the machine.
<b>Pulsing/pumping sound while extracting espresso or steaming milk.</b>	• The machine is carrying out the normal operation of the 15 bar Italian pump.	• No action required as this is the normal operation of the machine.
	• Water tank is empty.	• Fill tank.
	• Water tank is not fully inserted and locked into position.	• Push water tank down completely to lock into place.

<b>PROBLEM</b>	<b>POSSIBLE CAUSES</b>	<b>EASY SOLUTION</b>
<b>Water leaking.</b>	<ul style="list-style-type: none"> <li>• Auto purge feature. Water is automatically released into the drip tray after the steam and hot water functions to ensure the thermocoil is at the optimal temperature for extracting espresso.</li> </ul>	<ul style="list-style-type: none"> <li>• Ensure the drip tray is firmly pushed in place after using the steam and hot water functions.</li> <li>• Empty the drip tray regularly.</li> </ul>
	<ul style="list-style-type: none"> <li>• Water tank is not fully inserted and locked into position.</li> </ul>	<ul style="list-style-type: none"> <li>• Push water tank down completely to lock into place.</li> </ul>
	<ul style="list-style-type: none"> <li>• The silicone seal surrounding the shower screen needs to be replaced to ensure the portafilter is properly secured into the group head.</li> </ul>	<ul style="list-style-type: none"> <li>• Refer to 'Using the Allen Key', page 29.</li> </ul>
<b>Machine is on but ceases to operate.</b>	<ul style="list-style-type: none"> <li>• The safety thermal-cut out may have activated due to the pump or grinder overheating.</li> </ul>	<ul style="list-style-type: none"> <li>• Press the POWER button to switch the machine off and unplug from the power outlet. Allow to cool for about 30-60 minutes.</li> <li>• If problem persists, call Sage Customer Service on: 0808 178 1650</li> </ul>
<b>No ground coffee coming from grinder.</b>	<ul style="list-style-type: none"> <li>• No coffee beans in hopper.</li> </ul>	<ul style="list-style-type: none"> <li>• Filler hopper with fresh coffee beans.</li> </ul>
	<ul style="list-style-type: none"> <li>• Blocked grinder chamber or chute.</li> </ul>	<ul style="list-style-type: none"> <li>• Clean and clear grinder chamber and chute.</li> <li>• Refer to 'Advanced Cleaning for the Conical Burr Grinder', page 26.</li> </ul>
	<ul style="list-style-type: none"> <li>• Water / moisture in grinder chamber and chute.</li> </ul>	<ul style="list-style-type: none"> <li>• Clean and clear grinder chamber and chute.</li> <li>• Refer to 'Advanced Cleaning for the Conical Burr Grinder', page 26. Ensure burrs are thoroughly dry before re-assembling. It is possible to use a hair dryer to blow air into the grinder chamber.</li> </ul>
<b>FILTER SIZE LED's are flashing.</b>	<ul style="list-style-type: none"> <li>• Bean hopper is not attached correctly.</li> </ul>	<ul style="list-style-type: none"> <li>• Remove hopper, check for debris and then re-lock hopper into position.</li> </ul>
<b>Too much/too little ground coffee is being delivered to the filter basket.</b>	<ul style="list-style-type: none"> <li>• Grind amount settings are incorrect for particular grind size.</li> </ul>	<ul style="list-style-type: none"> <li>• Use the GRIND AMOUNT dial to increase or decrease the grind amount. Refer to 'Setting the Grind Amount', page 13 and 'Extraction Guide', page 22.</li> </ul>

**PROBLEM****POSSIBLE CAUSES****EASY SOLUTION**

---

**Too much/too little espresso is being delivered to the cup.**

- Grind amount and/or grind size settings and/or shot volumes require adjustment.

Try the following, one at a time:

- Reset the machine to its original default settings. Refer to 'Resetting Default Volumes', page 16.
  - Re-program the shot volumes. Refer to 'Re-Programming Shot Volume', page 15.
  - Adjust the grind amount and/or grind size settings. Refer to 'Setting the Grind Size', page 13, 'Setting the Grind Amount', page 13 and 'Extraction Guide', page 22.
- 

**Grinder is making a loud noise.**

- Blockage or foreign object in grinder.

- Remove hopper, check for debris or blockage. If necessary, clean and clear grinder chamber and chute. Refer to 'Cleaning the Conical Burr Grinder', page 26.
-



## Coffees to try

### CAPPUCCINO

A single shot of espresso with textured milk, garnished with drinking chocolate.



### ESPRESSO

Intense and aromatic, it is also known as a short black and is served in a small cup or glass.



### LATTÉ

A latté consists of a single espresso with textured milk and approx. 10mm of foam.



### MACCHIATO

Traditionally served short, the macchiato is also poured as a long black with a dash of milk or a dollop of textured milk.



### LONG BLACK

Add hot water first, then a shot of espresso (single or double) so that crema is maintained.



### RISTRETTO

A ristretto is an extremely short espresso of approximately 15ml, distinguished by its intense flavour and aftertaste.





Notes



Notes

