

EVERGREEN HOLECUTTING SYSTEM II



Evergreen Holecutting System II with Milwaukee 1/2" corded 0299-20, 120V, 60Hz, VSR drill motor, and items listed below.

Part No. 702 **\$595.00**



Evergreen Holecutting System II with DeWalt 1/2" cordless 20 volt XRP Model DCD940KX drill motor, and items listed below.

Part No. 1149 **\$792.00**



Evergreen Holecutting System II without drill motor, contact us for the correct drill ring to complete your holecutting system, and items listed below.

Part No. 704 **\$408.00**

Kits include: arbor, arbor extension, 4", stem adapter 1/2", cutting lubricant stick, speed reducer, two pilot drills, loosening washers, hex-key wrench, two open end wrenches, clamp and handle, drill ring, manual and cases.

Cutters: 3/4", 7/8", 1-1/8", 1-3/8", 1-5/8". Other cutter sizes are available (see holecutter list) and systems may be customized to meet your individual needs.

EVERGREEN SYSTEM II HOLECUTTERS

Part No.	Description			Net Price
610	5/8"	0.625	15.9 mm	20.50
611	11/16"	0.688	17.5 mm	21.00
612	3/4"	0.750	19.0 mm	21.50
613	13/16"	0.812	20.6 mm	22.50
614	7/8"	0.875	22.2 mm	23.50
616	1"	1.000	25.4 mm	25.00
618	1-1/8"	1.125	28.6 mm	26.50
619	1-3/16"	1.187	30.2 mm	27.50
620	1-1/4"	1.250	31.8 mm	28.50
621	1-5/16"	1.312	33.3 mm	30.00
622	1-3/8"	1.375	34.9 mm	30.50
624	1-1/2"	1.500	38.1 mm	33.50
626	1-5/8"	1.625	41.3 mm	36.00
628	1-3/4"	1.750	44.5 mm	42.50
630	1-7/8"	1.875	47.6 mm	45.00
632	2"	2.000	50.88 mm	46.50
634	2-1/8"	2.125	54.0 mm	61.00
636	2-1/4"	2.250	57.2 mm	63.00
638	2-3/8"	2.375	60.3 mm	65.00
640	2-1/2"	2.500	63.5 mm	78.50
642	2-5/8"	2.625	66.7 mm	95.00
648	3	3.000	76.2 mm	97.00
650	3-1/8"	3.125	79.4 mm	112.50
722.5		0.866	22.5 mm	24.00
730.5		1.201	30.5 mm	28.00
864	4"		102 mm	214.00
607	7/16"	0.437	11.10 mm	<i>Cutters at left available on special orders only. Contact us for pricing and availability.</i>
908		1.400	35.56 mm	
909		1.800	45.72 mm	
910		2.100	53.34 mm	
911		2.350	56.69 mm	
1146	1-17/64"		32.15 mm	

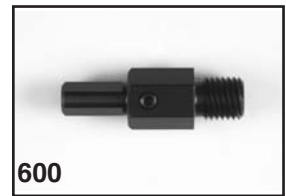

Part No.	Description	Net Price
600	Arbor	16.50
437	Arbor Extension 4" Long	21.90
674	Stem Adapter 1/2"*	12.00
380	Stem Adapter 3/8"*	12.00
705	Cutting Lubricant Stick	7.50
687	Input Shaft Reducer**	8.00
678	Output Adapter 1/2-20 Thrd	21.00
703	Holesaw Adapter***	43.50
1147	Input Shaft Extension	18.00



Selecting Accessories:

* Use a Stem Adapter (#674 & 380) to install the speed reducer in a drill chuck. Choose the appropriate stem adapter thread size 3/8" or 1/2" to match your speed reducer.

** Input Shaft Thread Reducer converts a 1/2-20-UNF speed reducer to a 3/8-24-UNF thread.

*** Holesaw Adapter allows use of conventional holesaws with 5/8-18-UNF threads. Includes a 1/4" pilot drill.

EVERGREEN SYSTEM II ESSENTIALS



873 & 874



656



705



Drill Rings



687



678



Cases



1147

Part No.	Description	Net Price
673	Speed Reducer 1/2" *	163.00
907	Drill Motor Milwaukee No. 0299-20 1/2"-Corded 0-850 RPM	184.00
913	Drill Motor DeWalt 1/2" XRP 20 Volt Cordless	360.00
435	Pilot Drill (double end) 3/16"	4.25
651	Loosening Washer 3/16"	0.70
652	Loosening Washer 3/32"	0.70
456	Hex-Key Wrench 7/8"	3.50
873	Open-End Wrench 7/8"	3.50
874	Open-End Wrench 1"	3.50
656	Clamp & Handle Assembly	18.50
468	Drill Ring 43 mm x 44 mm*	16.00
675	Drill Ring 43 mm x 16 mm*	16.00
677	Drill Ring 44 mm x 22 mm*	16.00
680	Drill Ring 46 mm x 16 mm*	16.00
871	Drill Ring 1.50" x .44"*	16.00
1148	Drill Ring 49 mm x 25 mm*	16.00
441	Operator's Manual	N/C
660	Case for Cutters (Small)	6.50
931	Torque Restraining Sleeve	45.00



* **Selecting a drill ring:** We offer various drill rings which allow the Holecutting System to be used on a variety of common drill motors. Contact us for the correct drill ring.

System Assembly Options: The Evergreen Holecutting System II is a versatile system for producing holes in a variety of situations. The above illustration shows several common configurations and the components necessary to construct each of them. This illustration is provided as an aid to those building a system.

REPAIR PARTS

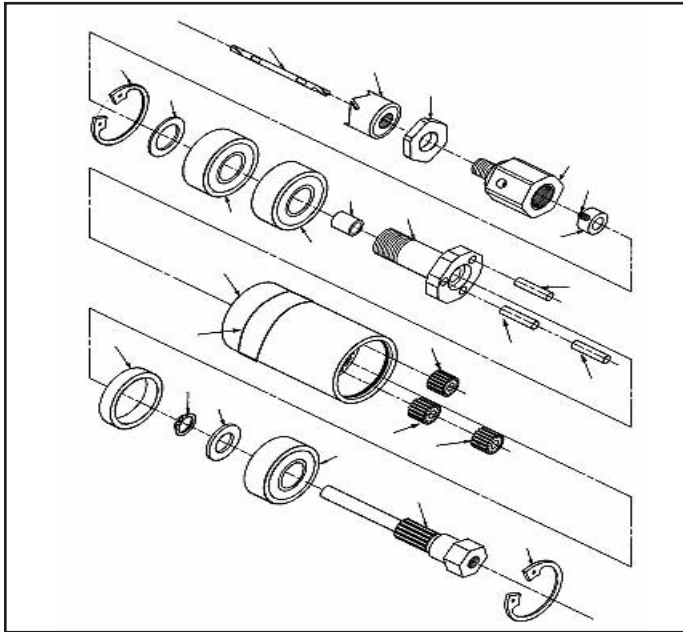

SPEED REDUCER PARTS LIST

Part No.	Price	Description
482	17.33	Output Adapter
491	0.21	Washer
490	3.47	Collar
455	0.18	Set Screw
474	1.10	Label

DRILLMATE BROACH METAL CUTTERS (3/4" DOC)

Part No.	Description	Net Price
1081	7/16"	35.80
1082	1/2"	37.80
1083	9/16"	42.75
1084	5/8"	44.50
1085	3/4"	49.50
1086	7/8"	57.00
1087	1"	65.00
1090	1/8" Pilot Pin	23.20
1080	Kit w/ arbor, pin, allen key & 5 cutters 7/16 - 3/4	258.55
705	Lubricant Stick	7.50
1093	Drillmate Arbor	71.25



Drillmate Broach
3/4" Depth of Cut



Evergreen Carbide
Annular
2" Depth of Cut

EVERGREEN CARBIDE ANNULAR CUTTERS (2" DOC)

Part No.	Description	Net Price
867	7/16"	61.25
868	17/32"	61.25
932	9/16"	61.25
933	5/8"	61.25
869	11/16"	61.25
934	3/4"	61.25
935	7/8"	61.25
936	15/16"	61.25
937	1"	66.50
938	1-1/16"	66.50
1088	Pilot	5.78
11016	Arbor & Hex Key	56.20
705	Lubricant Stick	7.50

WARRANTY

The Evergreen Tool Company Holecutting System II components are warranted to you as the original purchaser for one year from date of delivery against defects in workmanship and material. The Evergreen Tool Company will replace or repair any metal part which, in its opinion, is defective and has not been tampered with or subjected to misuse, abuse or exposed to highly corrosive conditions or has been modified except as expressly approved by Evergreen Tool Company, provided that written notice of alleged defect shall have been given to the Evergreen Tool Company within 30 days after discovery thereof and prior to the expiration of one year after delivery, and further provided that if the Evergreen Tool Company so instructs, such article or part thereof, with proof of purchase, is promptly returned to Evergreen Tool Company with shipping charges prepaid. This warranty does not include reimbursement for the original purchaser removal, set up, assembly or reinstallation of the fire system components.

The above warranty is the only one given by Evergreen Tool Company concerning the Holecutting System II components and shall be limited to the purchase price thereof. The Evergreen Tool Company does not assume or authorize any other person to assume for it any additional liability.

For repairs, parts and service of the Evergreen Tool Company Holecutting System II components, contact the Evergreen Tool Company, 715-582-0973, or email sales@evergreentool.com.

TERMS OF SALE

1. Net 30 days.
2. FOB Factory at Peshtigo, WI USA.
3. All prices are subject to change without notice and are subject to federal, state and local taxes where they are in effect.
4. Delivery is based on availability of labor and materials and is subject to delays in delivery without liability to Evergreen Tool Company from all causes beyond its control.
5. Title passed to buyer upon delivery to carrier.
6. Prices do not include any applicable taxes.
7. Evergreen Tool may, without liability, withhold delivery for financial or credit reasons.