

# TSSOP-28 BREAKOUT BOARD

(4.4 x 9.7 mm, 0.65 mm)

SKU: ICB70001

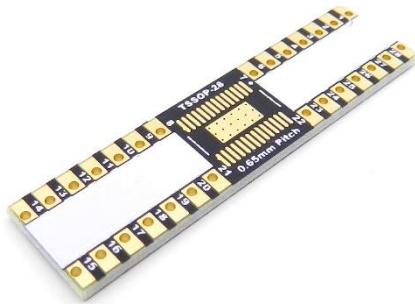

## Description

This is a breakout board that was designed to be a DIP adapter for the TSSOP-28 type SMD packages. Some of the SMD types that can be used with this board include: SOP, PSOP, TSOP, TSSOP 1, TSSOP 2, SSOP, MSOP, CSOP, EPTSSOP, HSOP, HTSSOP, QSOP, SOJ, BSOJ, TVSOP, VSSOP, VSP, VSO.

## Technical Details

Footprint Dimensions	
Body (mm):	4.4 x 9.7
Pitch (mm):	0.65
Thermal Pad (mm):	3 x 5.5
Breakout Board Dimensions	
Board Dimensions (mil):	450 x 1770
Board Thickness (mil):	62
Through-Hole Spacing (mil):	300 mil (X-axis)
	100 mil (Y-axis)
Breakout Board Specifications	
Board Layers:	2
Finish:	Immersion Gold
Copper:	1 oz
Traces (mil)	10
Trace Lengths (mil):	<750
Pin/Through-Hole Count:	28

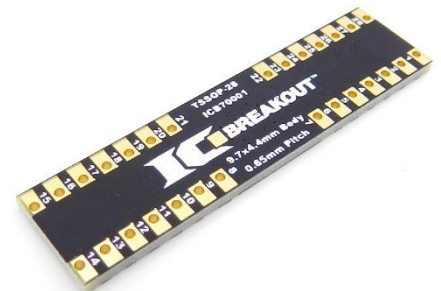

## What's Included?

<b>Parts Installed on Board:</b>	None
<b>Parts Included (but not installed):</b>	28 PIN Break Away Header (Straight)

## Additional Features

- Easily identifiable PIN 1 indicator and PIN numbers
- White silk "Label Pads" allow you to label the pins for quick reference
- Extended through-hole pads make for an easy connection point for surface mount parts
- Breadboard friendly pin spacing
- All boards have been E-tested for failures and are RoHS compliant

## Scale Image

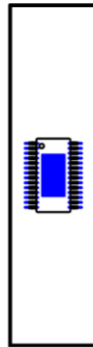

1:1 SCALE

*(Print this page to use the scale image to test the fit of the electronic part.)*

## Dimensions

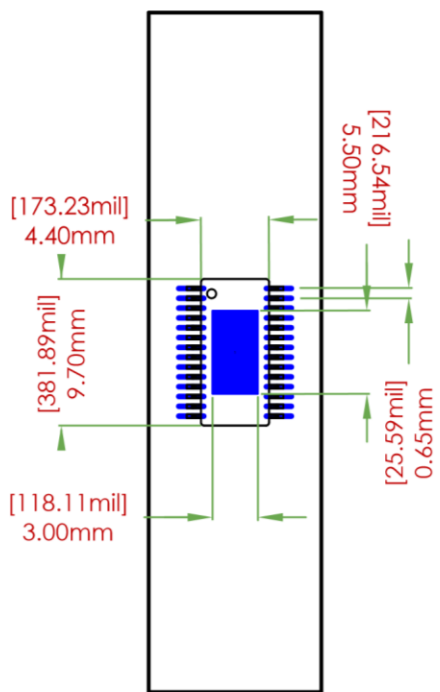

**FOOTPRINT  
DIMENSIONS**

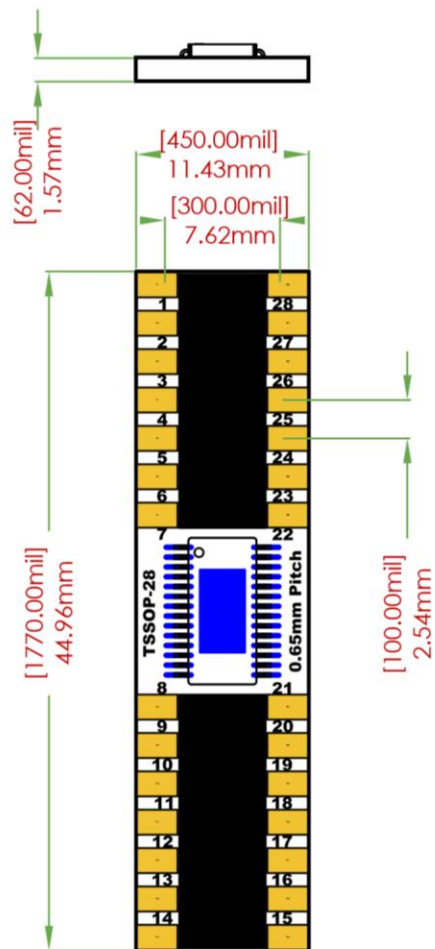

**BREAKOUT BOARD  
DIMENSIONS**