

Installation Instructions for S-Type: SSS, SS-R & SS-C

	<h4>Description</h4> <p>S-Type are master coded RFID (Radio Frequency Identification) safety switches with volt free contact outputs. They offer protection against manipulation, interference and defeat making them ideal for use in high risk applications.</p> <p>These tamper-proof safety switches feature agent resistant plastic enclosures encapsulated with epoxy resin for a protection level of IP67 and IP69K, ideal for use in wet, dusty and harsh environments</p> <p>A risk assessment should take place to establish that the specifications of these safety switches are suitable for the application required. See Technical Specifications below or contact Mechan Controls for further information.</p>
--	---

KEEP THIS GUIDE FOR FUTURE REFERENCE

The information is designed to help suitably qualified personnel install and operate Mechan Controls safety equipment. Before using this product, read this guide thoroughly along with any relevant European and/or National Standards E.g. Machinery Directive 2006/42/EC and its Amendments, Provision and Use of Work Equipment Regulations. Further information can be obtained from Mechan Controls Ltd.

Technical Specifications	SS-C	SSS	SS-R
Contacts	2 NO or 1 NO + 1 NC or 1 NO	2 NO or 1 NO + 1 NC	2 NO + 1 NC
Supply Voltage Options	24VDC (15% +/- 10%)	24VDC (+/- 15%)	24VDC (+/- 15%)
Safety Contact Rating	110Vac / 500mA or 24Vdc / 500mA	230Vac / 2A or 30Vdc / 2A	230Vac / 2A or 30Vdc / 2A
Safety Contact N/O	MIN 7mm ON / MAX 16mm OFF	MIN 7mm ON / MAX 16mm OFF	MIN 7mm ON / MAX 16mm OFF
Auxiliary Contact Rating	110Vac / 500mA or 24Vdc / 500mA	230Vac / 2A or 30Vdc / 2A	230Vac / 2A or 30Vdc / 2A
Auxiliary Contact N/C	MIN 7mm OFF / MAX 16mm ON	MIN 7mm OFF / MAX 16mm ON	MIN 7mm OFF / MAX 16mm ON
External Fuse (Customer Supplied)	0.3 Amp Fast Acting	3 Amps Fast Acting	3 Amps Fast Acting
Construction	Blue ABS	Blue ABS	Blue ABS
IP Rating	IP67 / IP69K	IP67 / IP69K	IP67 / IP69K
Operating Temperature	-25°C to +55°C	-25°C to +55°C	-25°C to +55°C
Fixing	4 X M4 Security Screws	4 X M4 Security Screws	4 X M4 Security Screws
Mounting Gap	2mm Between Switch & Actuator	2mm Between Switch & Actuator	2mm Between Switch & Actuator
Connection	Pre-Wired or M12 QD	Pre-Wired or M12 QD	Pre-Wired or M12 QD
Coding	Master Code	Master Code	Master Code
Indication	Red / Green LED	Green LED	Red / Green LED

Safety Related Data			
B10d	2,000,000	PFH	6.52 x 10 ⁻⁸
TM (Mission Time)	> 30 Years	PFHd	4.3 x 10 ⁻⁸ See Note 1
DC	99%	SFF	99%
MTTFd	High > 100 Years (Based on usage rate of 360 Days/Year, 24 Hours/Day, 10 Operations/Hour)		
Note 1: Based on dual channel wiring according to CAT 4. Diagnostic coverage provided by downstream control logic. DC - medium, MTTFd = 100 Years. Suitable for performance level applications PL _e according to ISO 13849-1. (SIL 3 according to IEC 62061)			

Safety Standards	
Approvals	CE Complies with all relevant sections of the CE Marking Directive
	cUL 508 Industrial Control
	TUV Approved
International Directives	Machinery Directive 2006/42/EC, Low Voltage Directive 2014/35/EU; EMC Directive 2014/30/EU, RoHS Directive 2011/65/EU
International Standards	EN 12100 Safety of Machinery. General principles for design.
	EN ISO 14119 Safety of Machinery. Interlocking devices associated with guards. Principles for design and selection. EN ISO 13849 Safety of Machinery. Safety related parts of control systems.
	EN ISO 62061 Safety of Machinery. Functional safety of safety related electrical, electronic and programmable electronic control systems
	EN 60204 Safety of Machinery. Electrical equipment of machines.
	EN 60947-5-1 Low-voltage switchgear and controlgear. EN 60947-5-3 Low-voltage switchgear and controlgear.

Dimensions

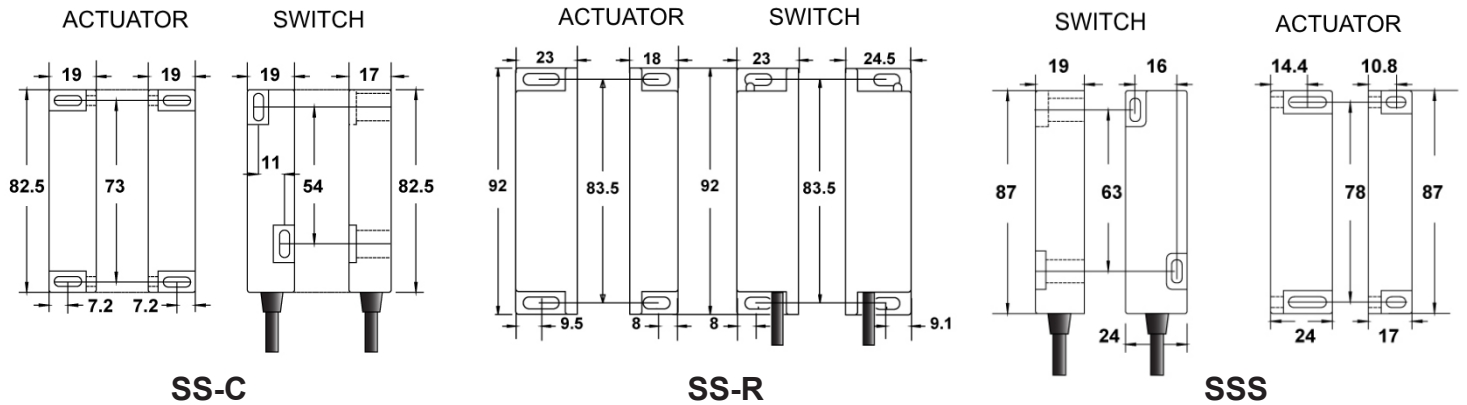

Mounting

Mechan S-Type safety switches can approach each other from most angles. When the guard is closed the targets on the printed face of the switch and actuator must be aligned.

Mount the switch on to the machine frame and the actuator on to the opening edge of the door.

Use the tamper proof screws provided to make the installation more secure.

Do not use the safety switch as a door stop. Leave a minimum of 50 mm between any adjacent switches.

EN 14119
Provides some mounting suggestions, see example opposite.

When fixing the safety switch to a sliding door (A), ensure that when the door is opened (B) it is not easily accessible, helping prevent the system being overridden.

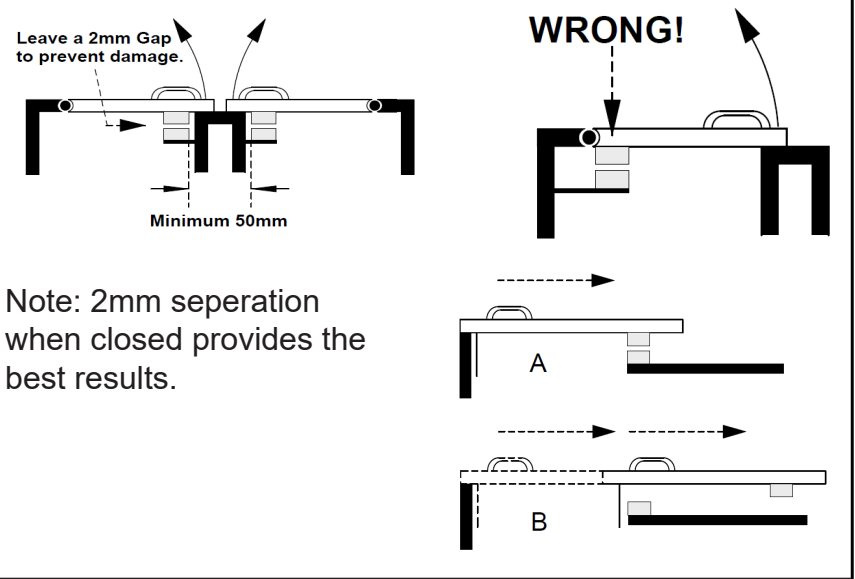

Indication

SSS has a green LED which is illuminated when the switch is powered and the gate is closed.

The SS-R and SS-C have a dual colour LED (Red & Green) Red when the power is on and gate open, green when the gate is closed.

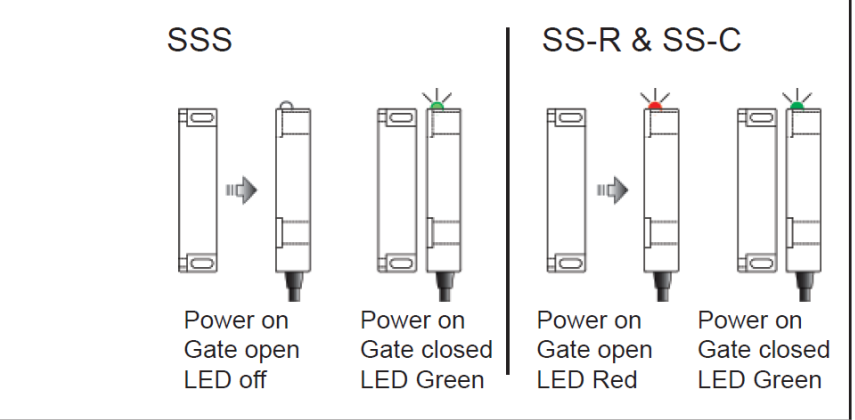

Connections & Fuses

PRE-WIRED

SSS-11
SS-C-11

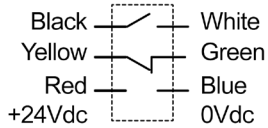

SS-C-20

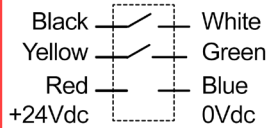

SSS-20

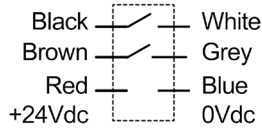

SS-R-21

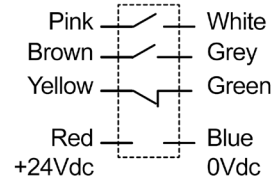

SS-R-21-FP

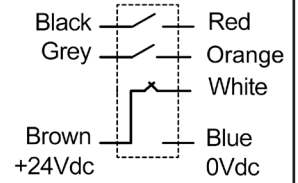

QUICK DISCONNECT

SS-C-10

Connector Description Cable

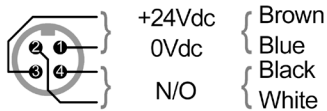

Connector
M12
4 Pole, Single Key way

SSS-11

Connector Description Cable

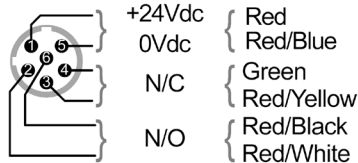

Connector
Micro AC 1/2" - 20
6 Pole, Dual Key Way

SSS-20

Connector Description Cable



Connector
Micro AC 1/2" - 20
6 Pole, Dual Key Way

LEADED QUICK DISCONNECT

SS-C-20

Connector Description Cable

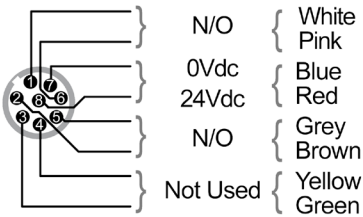

Connector
150mm Lead, M12
8 Pole, Single Key way

SS-R-21

Connector Description Cable

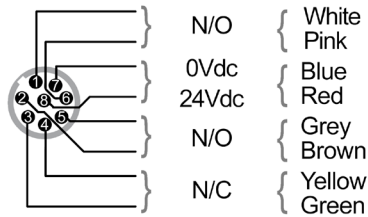

Connector
150mm Lead, M12
8 Pole, Single Key way

Contact Operation

The N/O contacts on the Mechan switches are open when the actuator is away from the switch. When the actuator is within the specified operating distance the N/O contact will close and the N/C contact will open.

Fuses

All safety contacts should be fused externally
SS-C CONTACTS = 0.3 Amps Quick Blow Fuse
SS-S CONTACTS = 3 Amps Quick Blow
SS-R CONTACTS = 3 Amps Quick Blow

SS-C & SS-R LQD
M12 Leaded quick disconnect with 150mm connecting lead to the switch



SSS-QD
M12 quick disconnect mount in the switch body

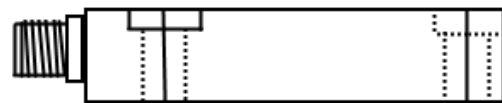

Operation

Mechan S-Type safety switches can approach each other from most directions.

When closed the targets printed on the front face of the switches must be aligned. Large target to large target and small target to small target as shown opposite.

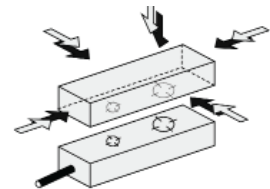

When the power is on and the switch and actuator are apart the NO contact(s) will be open and the NC contact will be closed. When the actuator is brought within the specified switching distance (see page 1) the NO contact(s) will close and the NC contact will open.

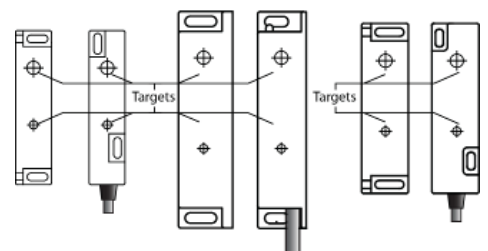

Installation Instructions for S-Type: SSS, SS-R & SS-C

Switching Characteristics

The chart shows the switching points in millimetres

SSS, SS-R & SS-C

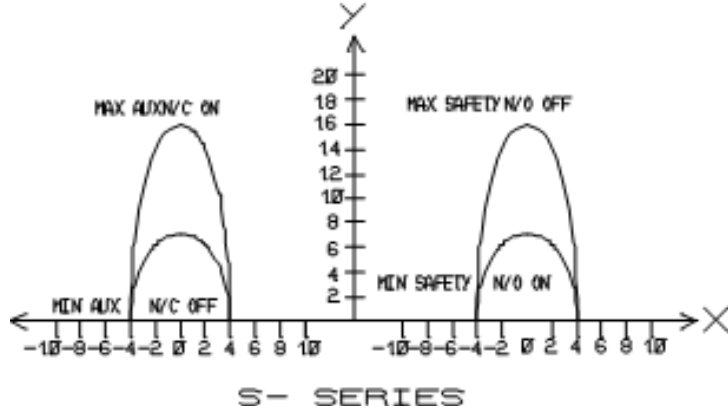

Recommended Safety Control Unit

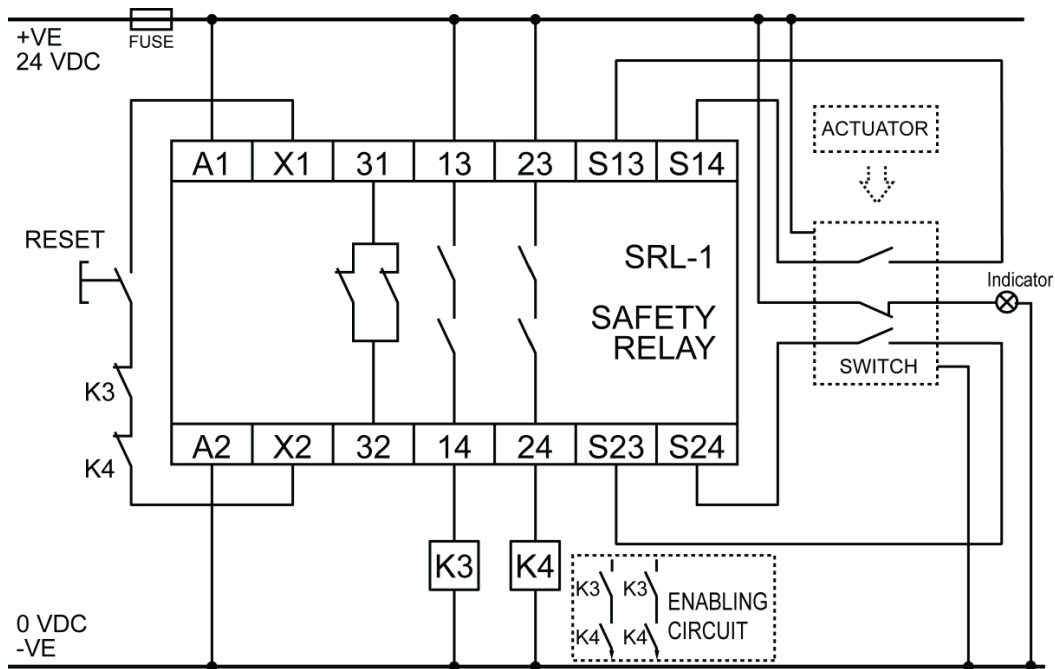

IMPORTANT

CONNECTION TO A SAFETY RELAY

SSS & SS-R non-contact safety switches are designed work with most safety relays on the market.

SS-C is designed to be connected to a safety control circuit which has less than 0.5 Amps inrush current.

All contacts should be externally fused.

Recommended Safety Control Unit Mechan Part Number: SRL-1 24VAC/DC or EM1 & ESM

Maintenance

It is recommended to check the safe operation of the switches and look for signs of damage or excessive wear on a weekly basis. Damaged units should be replaced or returned to the manufacturer for repair where practical.

Notes

In the interest of product development specifications are subject to change without notice. It is the responsibility of the user to ensure compliance with any acts or by-laws in place. All information regarding Mechan equipment is believed to be accurate at the time of printing. Responsibility cannot be accepted for errors or omissions.

Contact Details

Mechan Controls Ltd, 14/16 Seddon Place, Stanley Industrial Estate, WN8 8EB, United Kingdom, Tel: +441695722264,
Web: www.mechancontrols.com