

Ram Mount Milling Machine Guard

Part # MG-3

Our most popular milling machine guard.

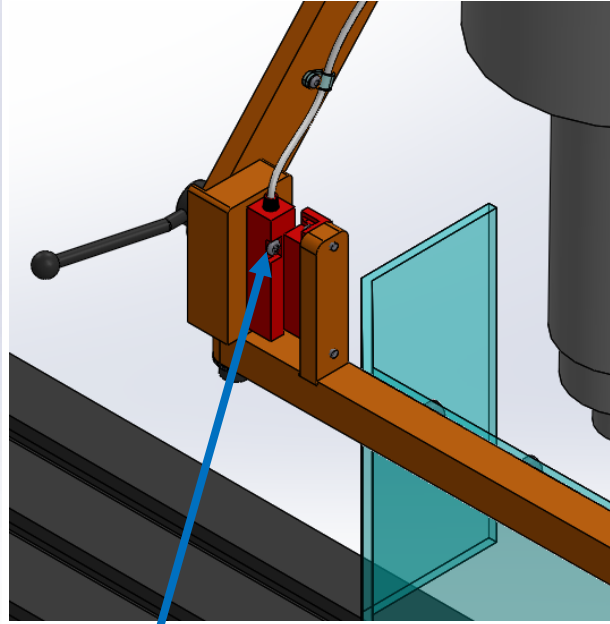
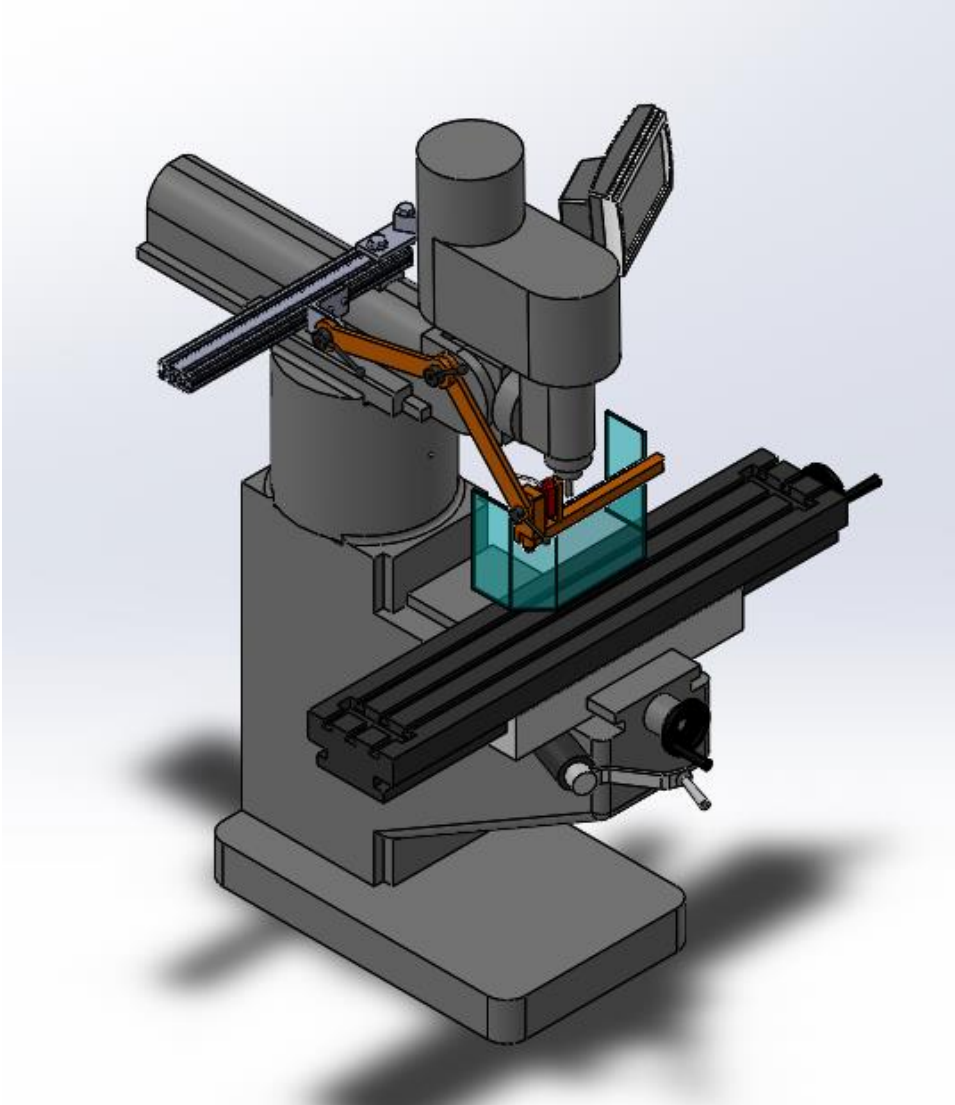

Optional safety switch / interlock.
Can be added at a later date also.

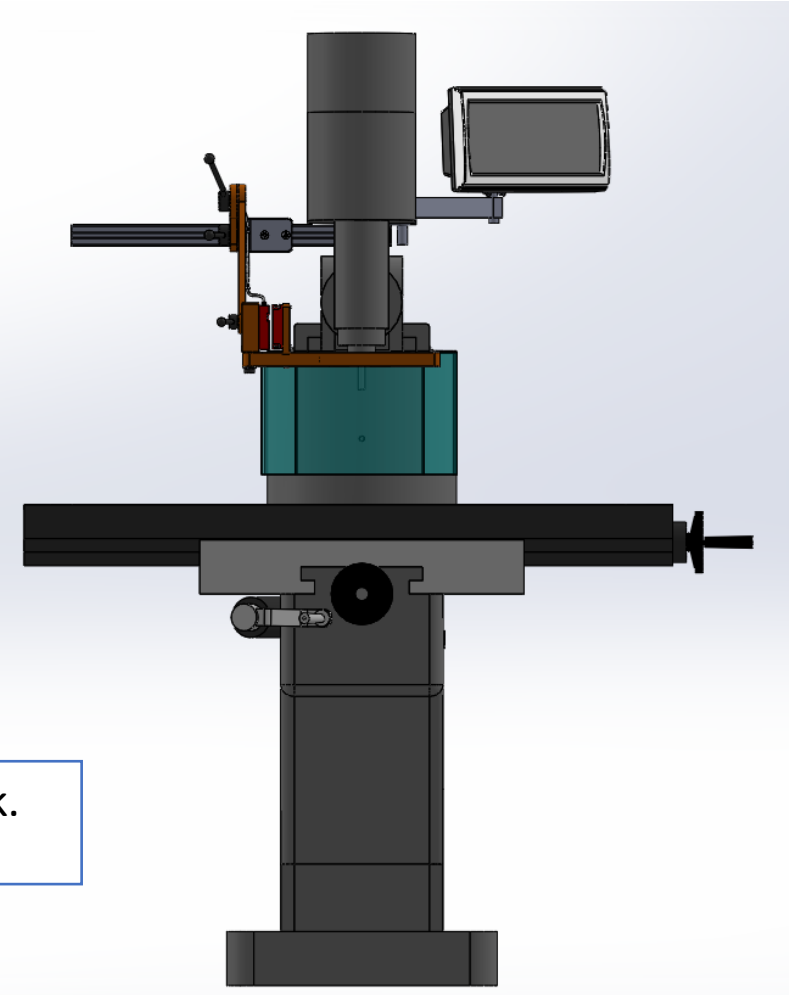

Installed photos.



ATS
MACHINE SAFETY
SOLUTIONS

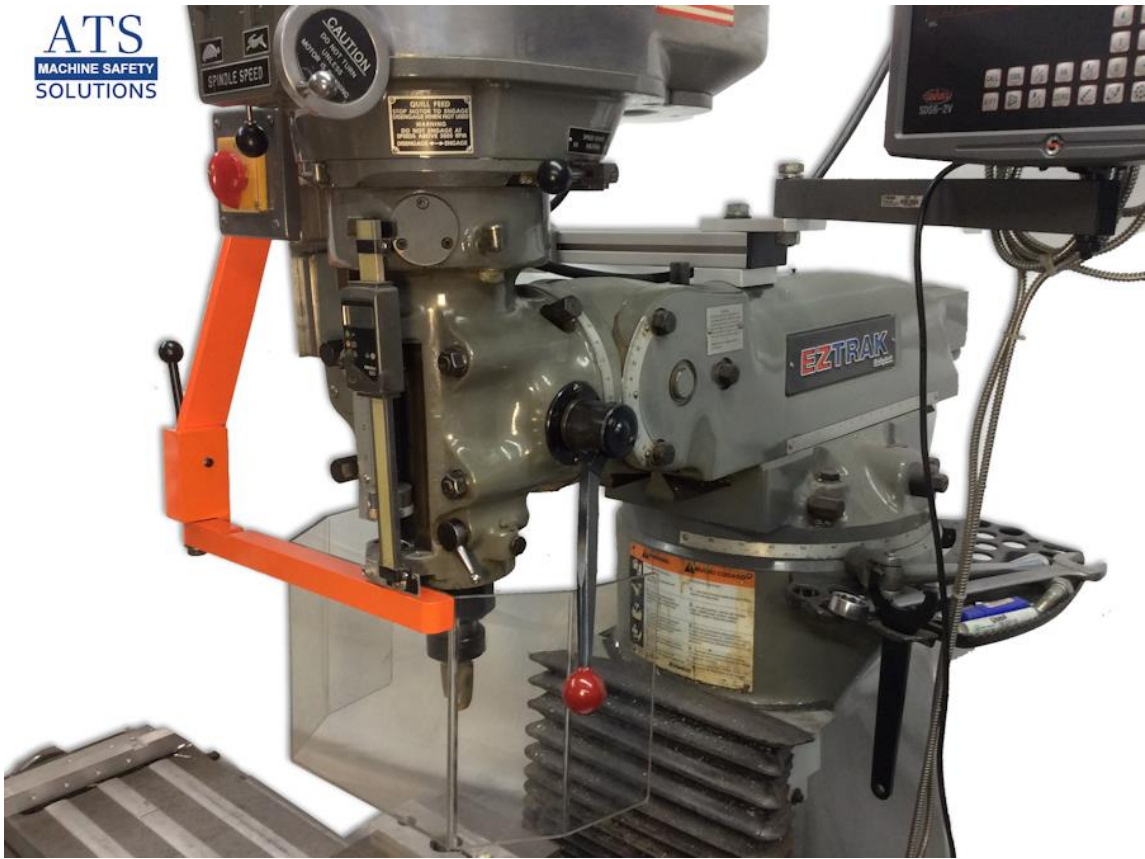

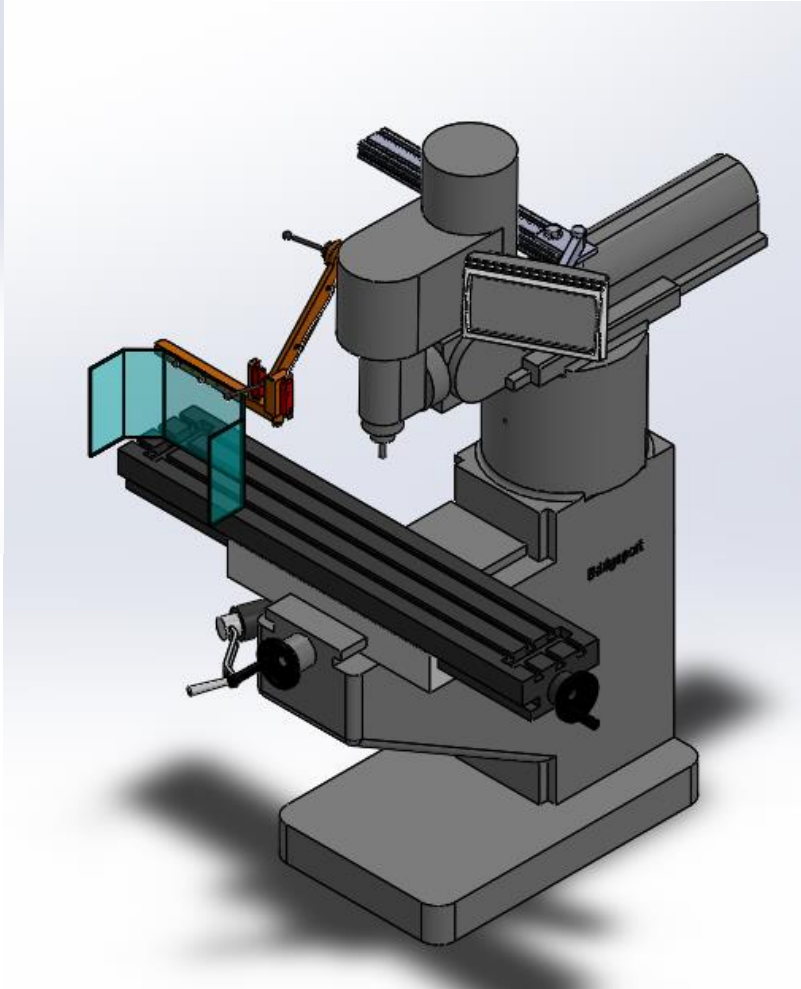
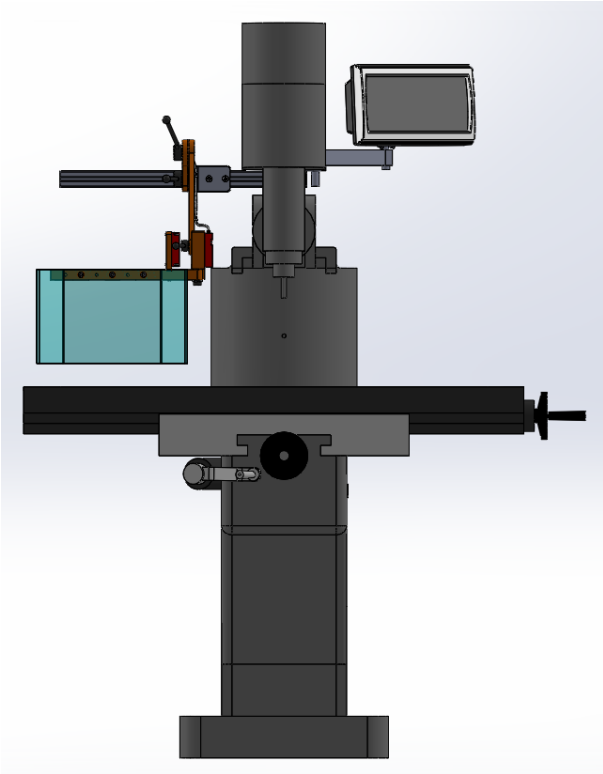

Features:

- Installs in minutes - Truly bolt-on, no drilling required to install.
- Front arm swings open to the left 180 degrees for easy setup and work access
- Heavy duty steel adjustable handles- pull out and orient 360 degrees
- Articulating arms allow operator to easily position the shield to fit different workpieces or fixtures.
- Includes curved lexan shield only. We also have an optional 3-sided and flat shield.
- All CNC billet aluminum construction, Powder coated "Safety Orange"
- Made in USA

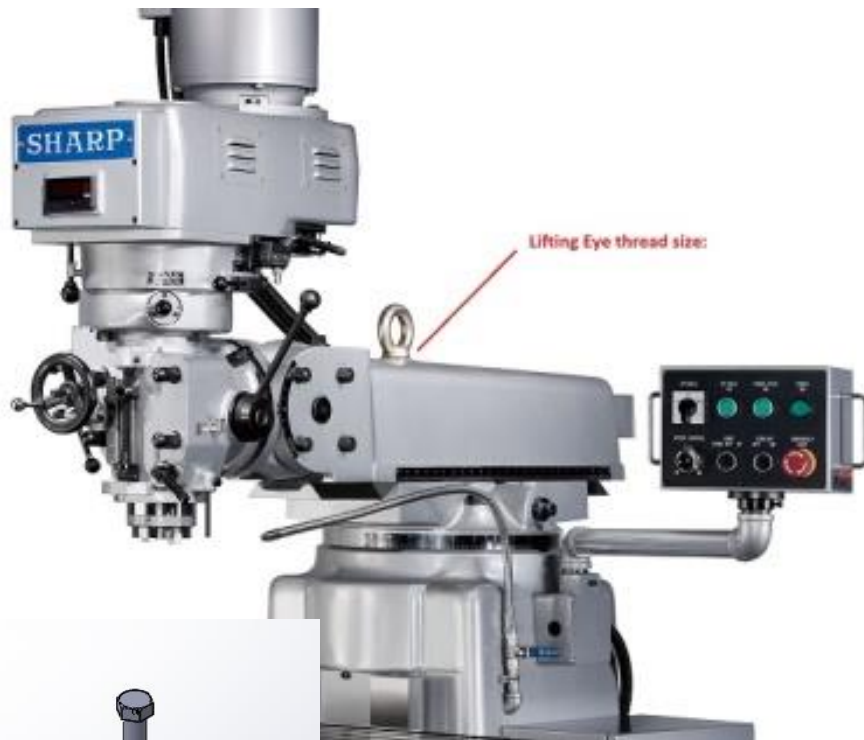

Bolts directly to the existing threaded hole (lifting point) on the ram. No drilling into the machine to install!

We will ask for the brand of your machine or 2 measurements when ordering so that we can supply you the correct hardware and arms!

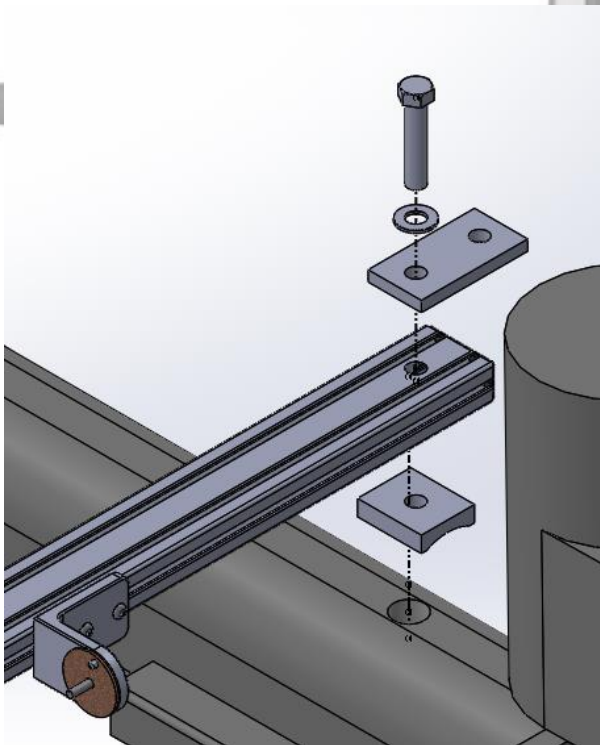

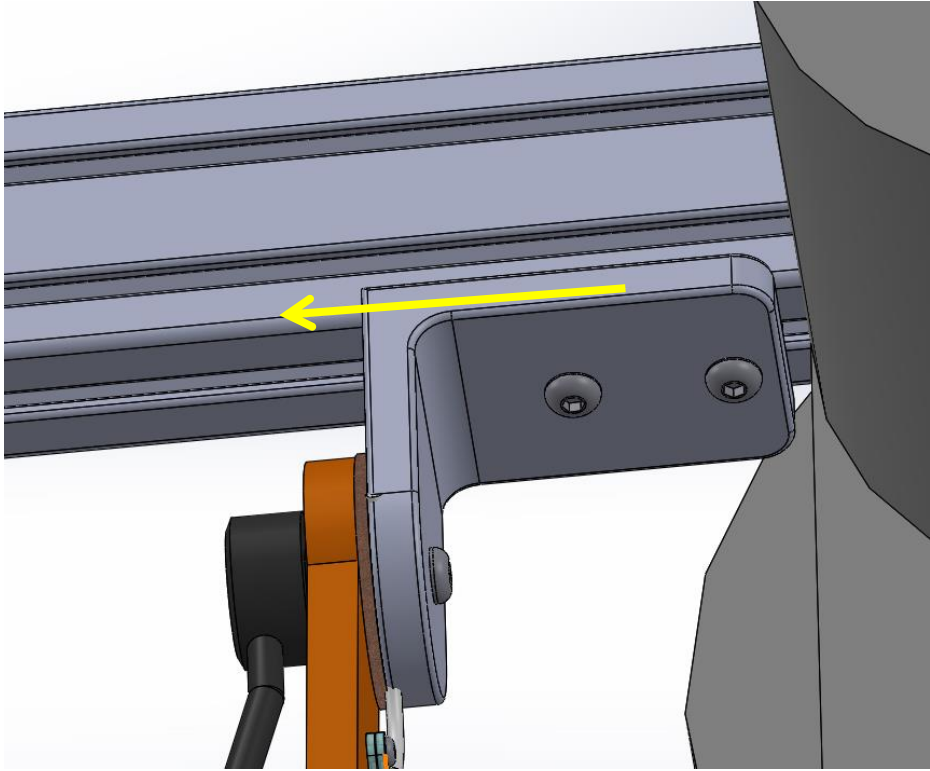

Horizontal mounting rail and adjustable bracket allow the guard to be re-positioned if tilting the head over at an angle.

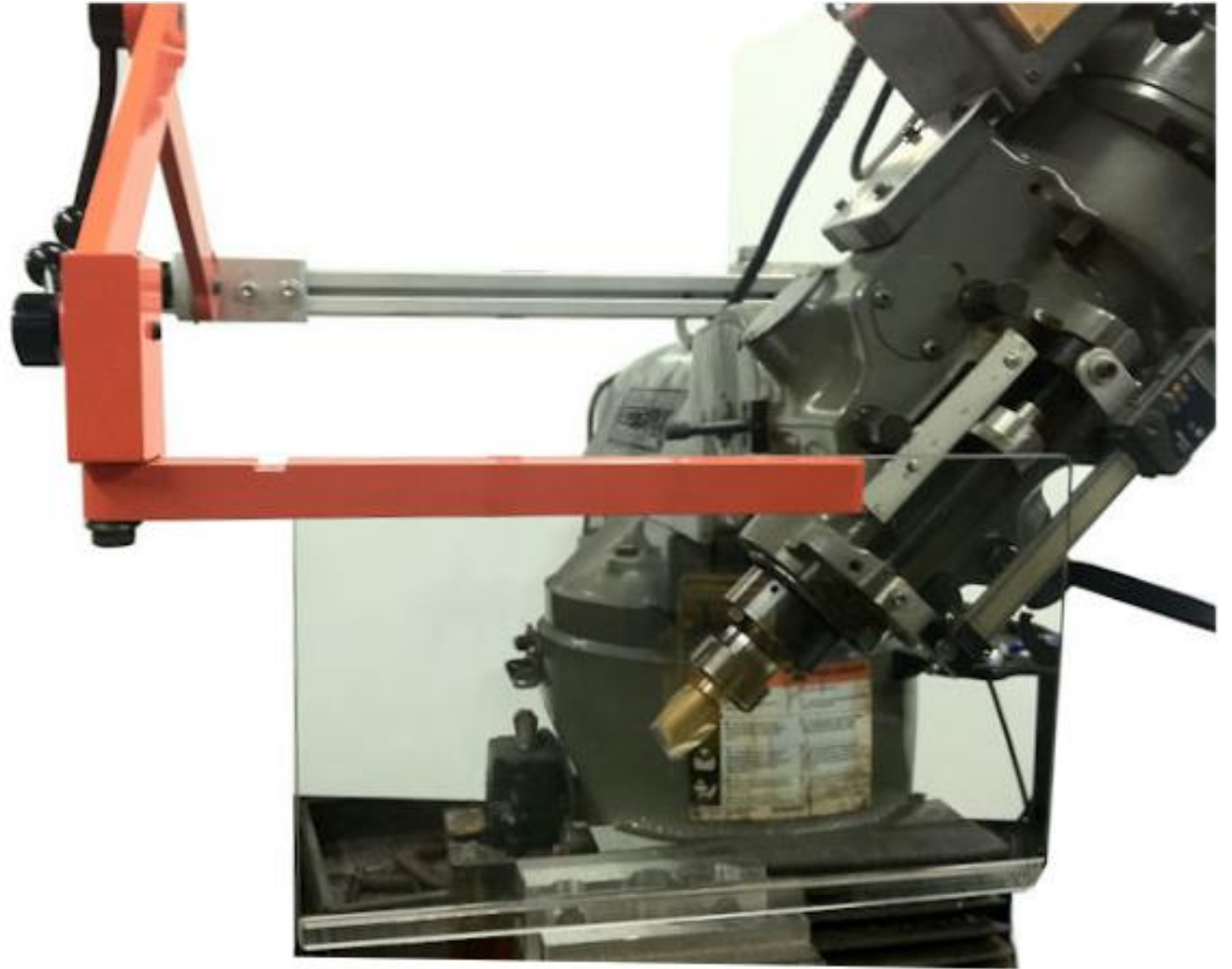

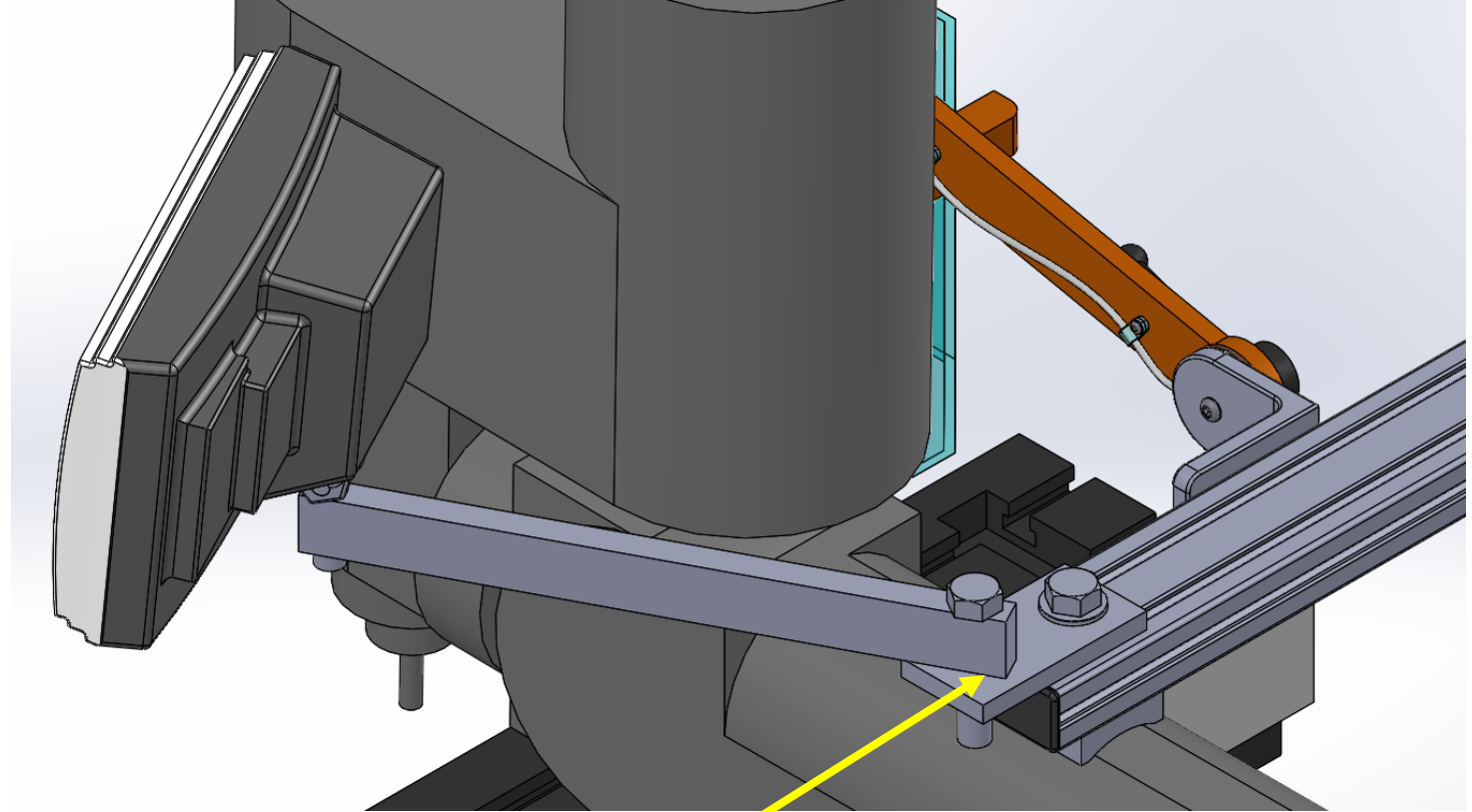
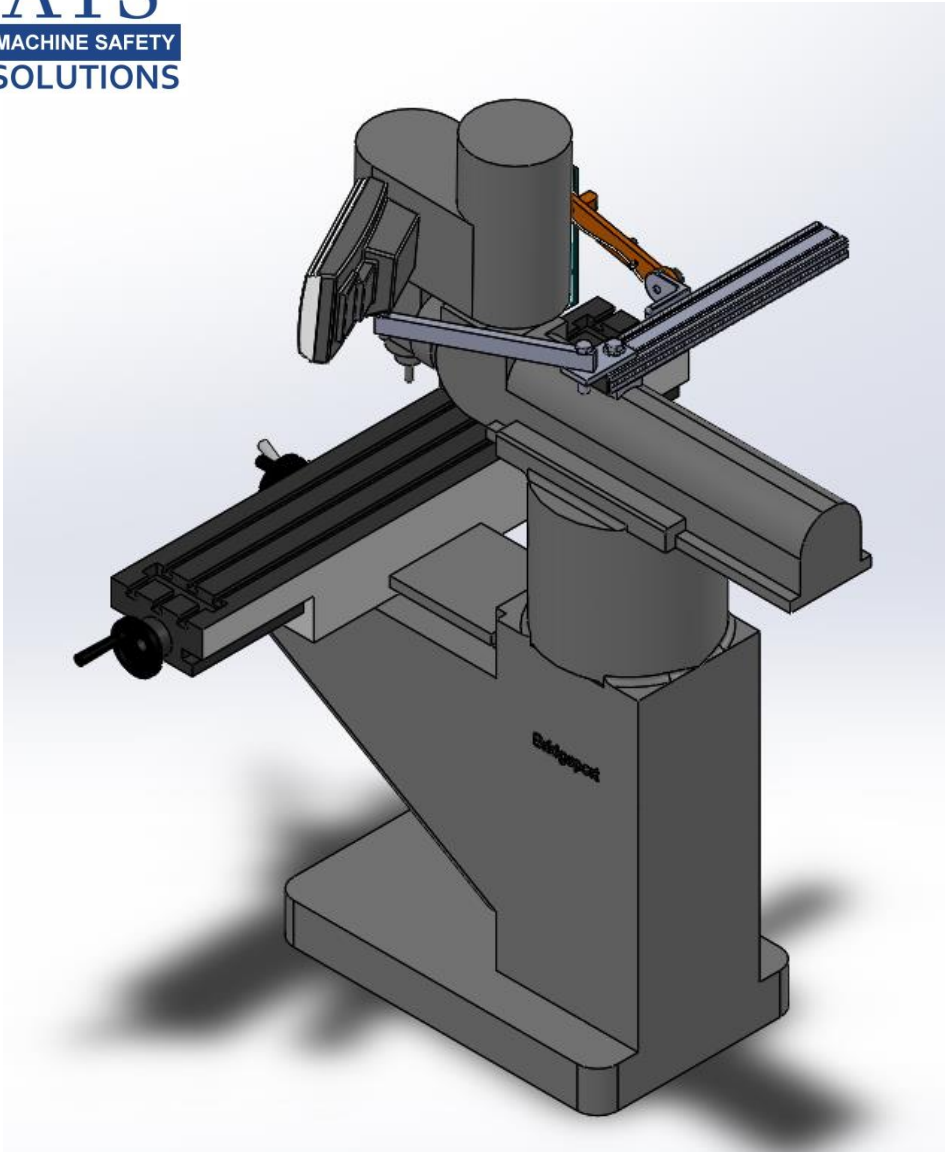

The included upper bracket allows the digital readout to be re-located.

The MG-3 comes with the curved lexan shield, RMS-1.

The Optional flat shield is used when the curved shield is not possible, such as when using a rotary indexer, or the head is tilted at an angle.

Custom shields available.

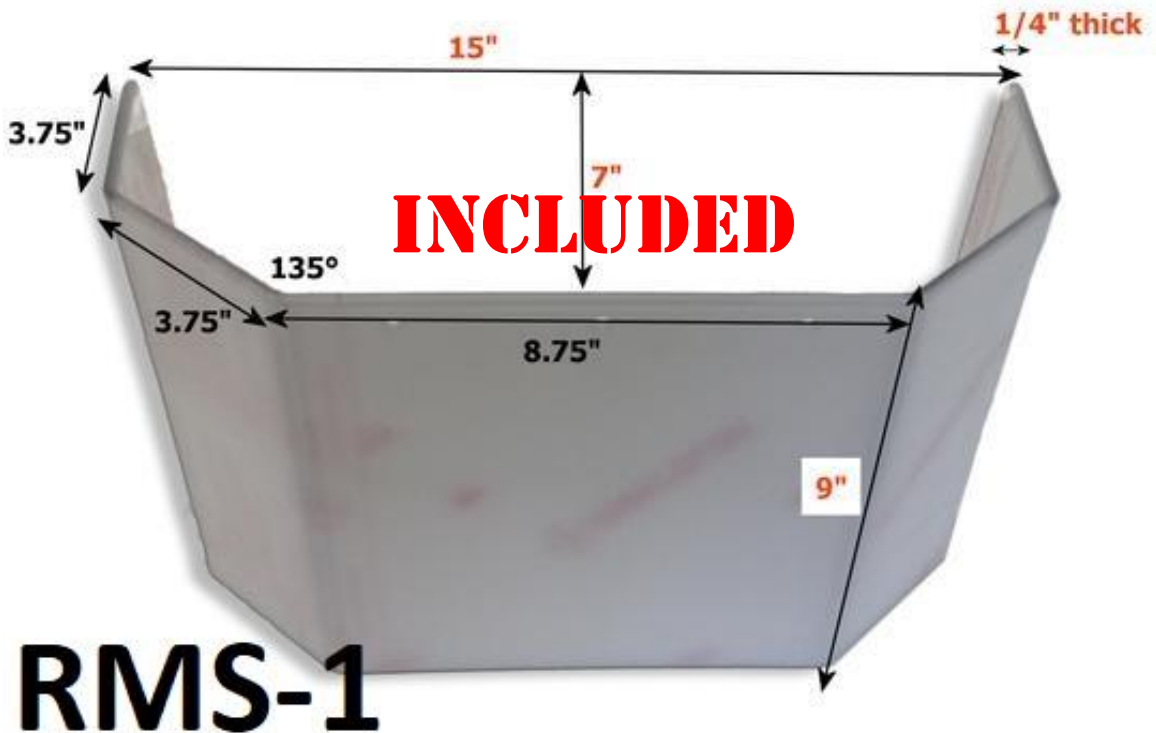

RMS-1

Replacement curved Mill shield

OPTIONAL



RMS-2

Replacement mill
shield, FLAT