

Head Mount Milling Machine Guard, Part # MG-2

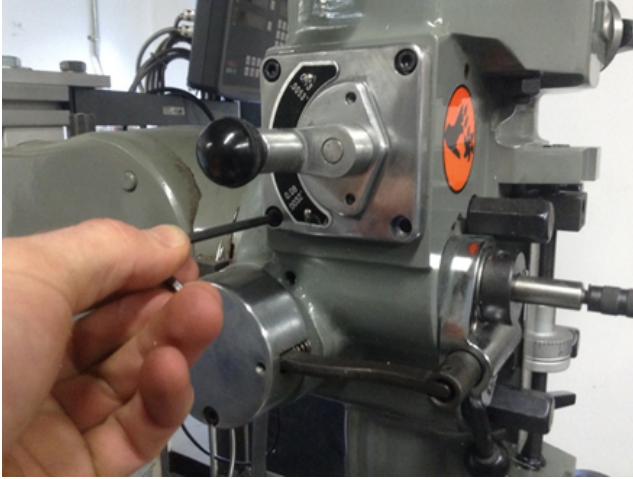

1. Remove the (4) quill feed plate bolts

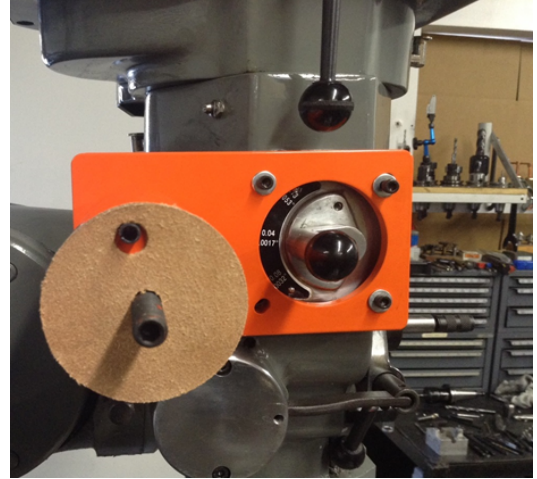

2. Install plate in orientation shown, using the longer bolts supplied.

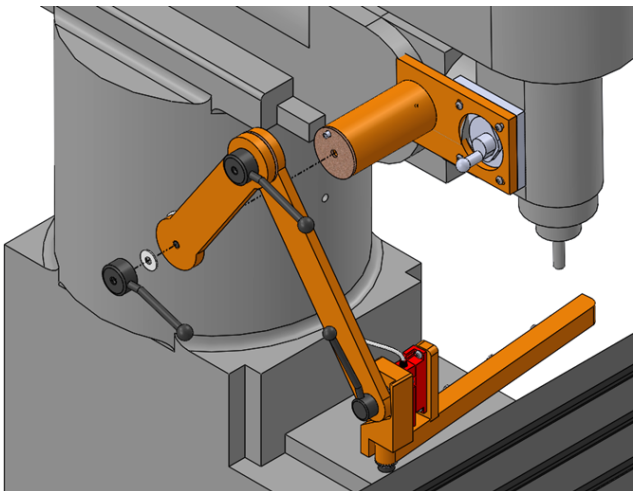

3. Install the guard, metal washer, and handle. The handles are adjustable position.

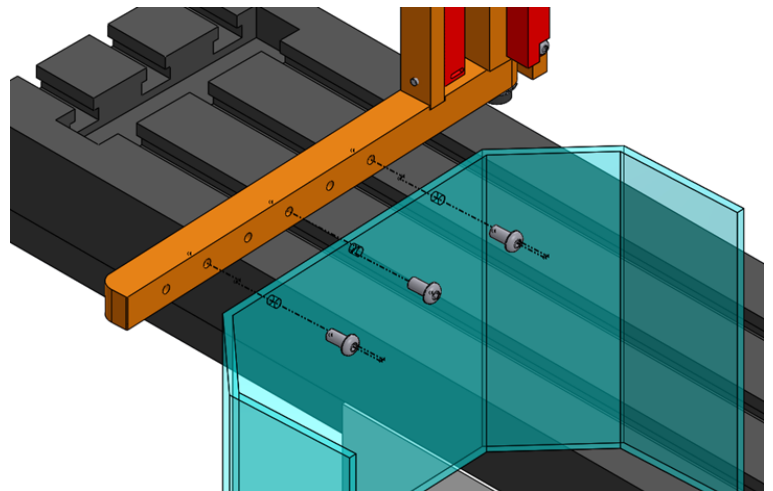

4. Install the shield. You can choose from two sets of hole patterns.

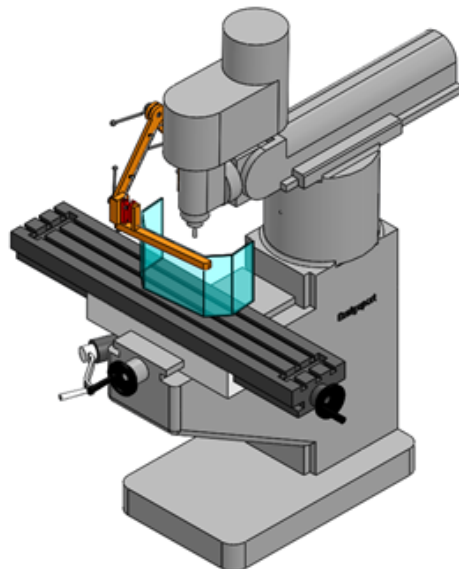

OVER



Shield Use

Adjust so the bottom is just above the vise, allowing the guard to swing open without hitting the vise or any obstruction.

Positioning the shield

Never adjust guard while spindle is on!

If the table is raised up or down, a large part is on the table, etc, you will need to adjust the guard. Adjust so that the front arm is level in both planes.

Hold the pivot block with one hand, and loosen all three handles. Position guard, and tighten handles. You may need to follow the step below and re-torque.

Handle Adjustment

Each steel handle can be rotated on splines while tight. This allows you to re-position them for easiest use (leverage). To do this, pull outward on them, and rotate to the desired position, then release.

