

ATS Hinged Lathe Chuck Guard, 8" Wide

ATS
MACHINE SAFETY
SOLUTIONS

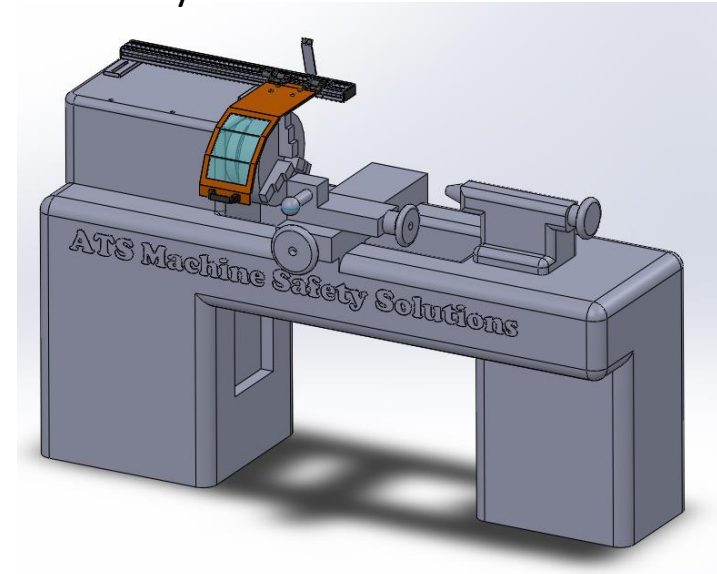

- Fits 8 – 12" diameter lathe chucks and on up to some 16" chucks
- 11 ga. mild steel, powder coated safety orange, ¼" thick lexan window
- Zinc alloy steel friction hinges
- Includes horizontal aluminum extrusion mounting rail and slotted brackets
- Available with an interlock switch now or add one later easily.



Part # CC816 (Standard)



Part # CC816-INT (Interlocked)



Standard Horizontal Mounting Rail & Slotted Brackets Included. You only need to source longer gearbox bolts to install.

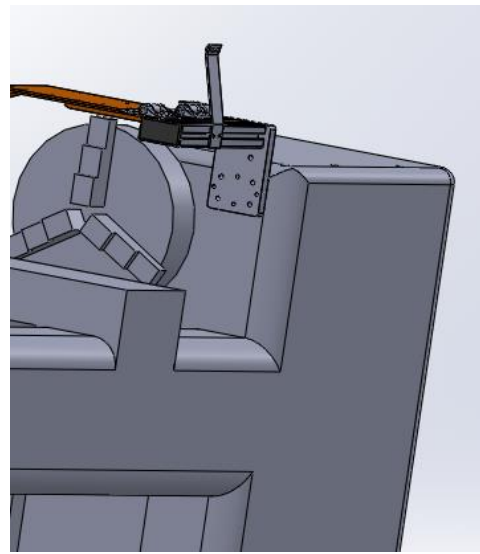

Optional Mount bracket requires drilling/tapping into the vertical face of headstock as shown. This is for lathes where the horizontal rail cannot be used.

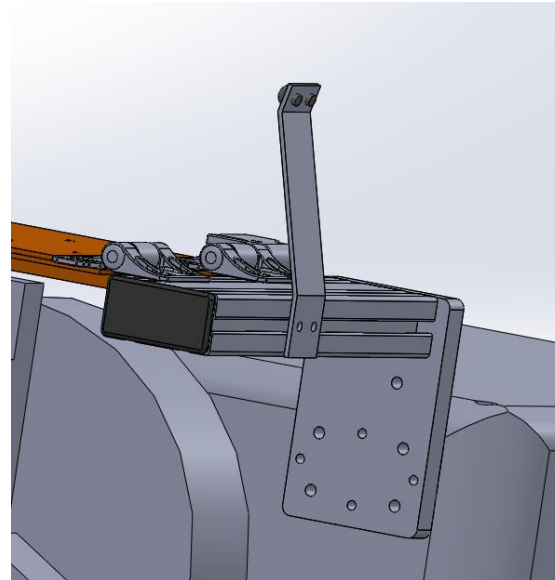

Optional Safety Interlock Switch. When wired in to the machine's control, the machine will not start without the guard closed.

