

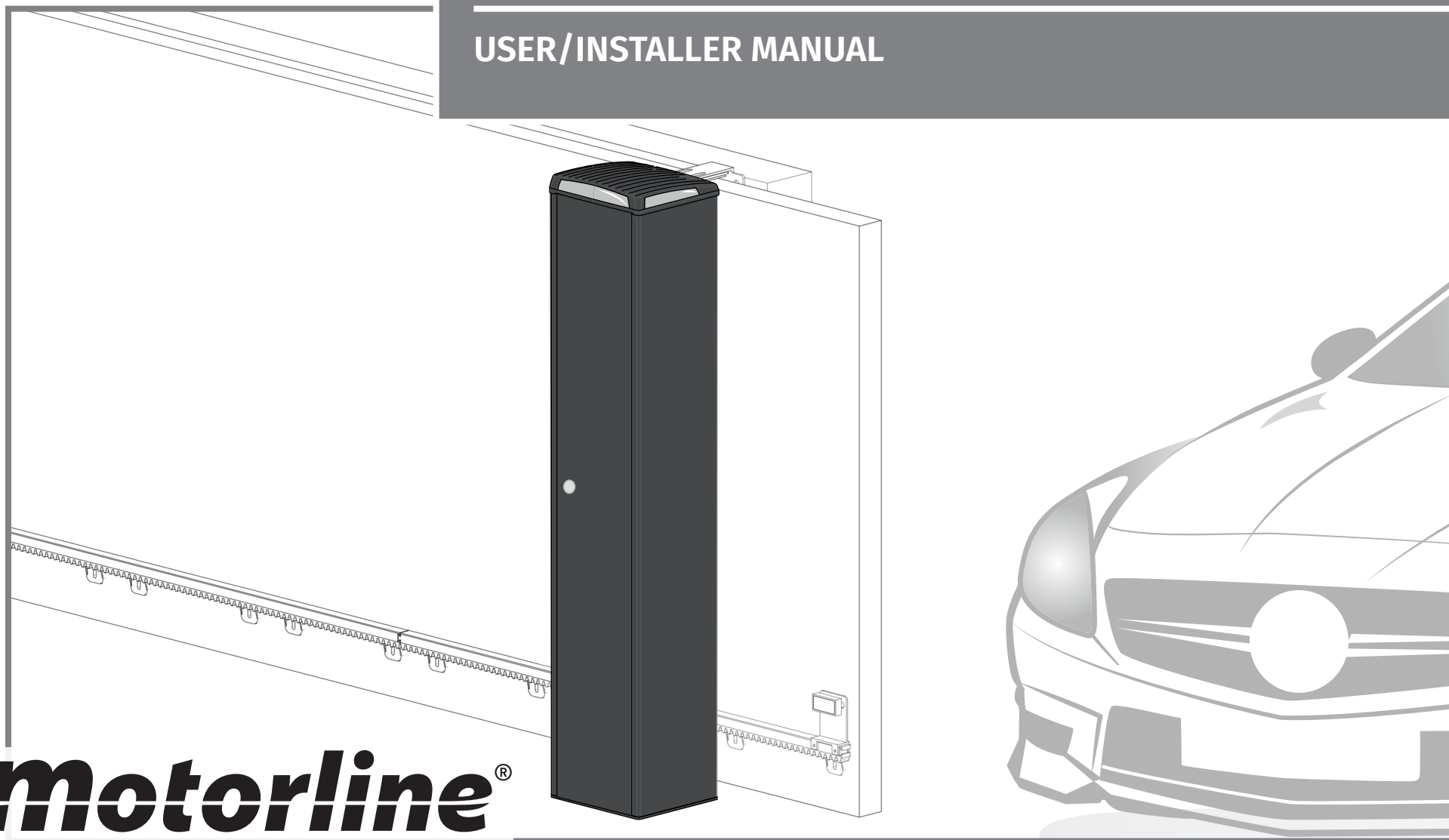

# FORT

## USER/INSTALLER MANUAL



**motorline**<sup>®</sup>  
PROFESSIONAL





# 00. CONTENT

## INDEX

<b>01. SAFETY INSTRUCTIONS</b>	
STANDARDS TO FOLLOW	1B
<b>02. DIAGRAM</b>	
MAP OF INSTALLATION	4
<b>03. OPERATOR</b>	
TECHNICAL SPECIFICATIONS	5A
DIMENSIONS	5A
<b>04. INSTALLATION</b>	
UNLOCK THE MOTOR	5B
PRE-INSTALLATION	5B
CREATE FOUNDATION AND FIXING AUTOMATION	6A
FIXING AUTOMATION IN AN EXISTING FOUNDATION	6B
METAL GEAR RACK INSTALLATION	7A
NYLON GEAR RACK INSTALLATION	7B
APPLICATION OF THE MAGNETIC LIMIT SWITCH	8A
<b>05. MAINTENANCE</b>	
MAINTENANCE	8B
<b>06. CONNECTION SCHEME</b>	
230V/110V MOTOR (MC50SC)	9
24V MOTOR (MC41SP)	10
<b>07. COMPONENTS TEST</b>	
SCHEMES FOR TESTS	11
<b>08. TROUBLESHOOTING</b>	
FINAL CONSUMERS INSTRUCTIONS	12
SPECIALIZED TECHNICIANS INSTRUCTIONS	12

# 01. SAFETY INSTRUCTIONS

## STANDARDS TO FOLLOW

	This product is certified in accordance with European Community (EC) safety standards.
<b>RoHS</b>	This product complies with Directive 2011/65/EU of the European Parliament and of the Council, of 8 June 2011, on the restriction of the use of certain hazardous substances in electrical and electronic equipment.
	(Applicable in countries with recycling systems). This marking on the product or literature indicates that the product and electronic accessories (eg. Charger, USB cable, electronic material, controls, etc.) should not be disposed of as other household waste at the end of its useful life. To avoid possible harm to the environment or human health resulting from the uncontrolled disposal of waste, separate these items from other types of waste and recycle them responsibly to promote the sustainable reuse of material resources. Home users should contact the dealer where they purchased this product or the National Environment Agency for details on where and how they can take these items for environmentally safe recycling. Business users should contact their vendor and check the terms and conditions of the purchase agreement. This product and its electronic accessories should not be mixed with other commercial waste.
	
	This marking indicates that the product and electronic accessories (eg. charger, USB cable, electronic material, controls, etc.) are susceptible to electric shock by direct or indirect contact with electricity. Be cautious when handling the product and observe all safety procedures in this manual.

# 01. SAFETY INSTRUCTIONS

## **GENERAL WARNINGS**

- This manual contains very important safety and usage information. very important. Read all instructions carefully before beginning the installation/usage procedures and keep this manual in a safe place that it can be consulted whenever necessary.
- This product is intended for use only as described in this manual. Any other enforcement or operation that is not mentioned is expressly prohibited, as it may damage the product and put people at risk causing serious injuries.
- This manual is intended firstly for specialized technicians, and does not invalidate the user's responsibility to read the "User Norms" section in order to ensure the correct functioning of the product.
- The installation and repair of this product may be done by qualified and specialized technicians, to assure every procedure are carried out in accordance with applicable rules and norms. Nonprofessional and inexperienced users are expressly prohibited of taking any action, unless explicitly requested by specialized technicians to do so.
- Installations must be frequently inspected for unbalance and the wear signals of the cables, springs, hinges, wheels, supports and other mechanical assembly parts.
- Do not use the product if it is necessary repair or adjustment is required.
- When performing maintenance, cleaning and replacement of parts, the product must be disconnected from power supply. Also including any operation that requires opening the product cover.
- The use, cleaning and maintenance of this product may be carried out by any persons aged eight years old and over and persons whose physical, sensorial or mental capacities are lower, or by persons without any knowledge of the product, provided that these are supervision and instructions given by persons with experienced in terms of usage of the product in a safe manner and who understands

the risks and dangers involved.

- Children shouldn't play with the product or opening devices to avoid the motorized door or gate from being triggered involuntarily.

## **WARNINGS FOR TECHNICIANS**

- Before beginning the installation procedures, make sure that you have all the devices and materials necessary to complete the installation of the product.
- You should note your Protection Index (IP) and operating temperature to ensure that is suitable for the installation site.
- Provide the manual of the product to the user and let them know how to handle it in an emergency.
- If the automatism is installed on a gate with a pedestrian door, a door locking mechanism must be installed while the gate is in motion.
- Do not install the product "upside down" or supported by elements do not support its weight. If necessary, add brackets at strategic points to ensure the safety of the automatism.
- Do not install the product in explosive site.
- Safety devices must protect the possible crushing, cutting, transport and danger areas of the motorized door or gate.
- Verify that the elements to be automated (gates, door, windows, blinds, etc.) are in perfect function, aligned and level. Also verify if the necessary mechanical stops are in the appropriate places.
- The central must be installed on a safe place of any fluid (rain, moisture, etc.), dust and pests.
- You must route the various electrical cables through protective tubes, to protect them against mechanical exertions, essentially on the power supply cable. Please note that all the cables must enter the central from the bottom.
- If the automatism is to be installed at a height of more than 2,5m from the ground or other level of access, the minimum safety and

# 01. SAFETY INSTRUCTIONS

health requirements for the use of work equipment workers at the work of Directive 2009/104/CE of European Parliament and of the Council of 16 September 2009.

- Attach the permanent label for the manual release as close as possible to the release mechanism.
- Disconnect means, such as a switch or circuit breaker on the electrical panel, must be provided on the product's fixed power supply leads in accordance with the installation rules.
- If the product to be installed requires power supply of 230Vac or 110Vac, ensure that connection is to an electrical panel with ground connection.
- The product is only powered by low voltage safety with central (only at 24V motors)

## WARNINGS FOR USERS

- Keep this manual in a safe place to be consulted whenever necessary.
- If the product has contact with fluids without being prepared, it must immediately disconnect from the power supply to avoid short circuits, and consult a specialized technician.
- Ensure that technician has provided you the product manual and informed you how to handle the product in an emergency.
- If the system requires any repair or modification, unlock the automatism, turn off the power and do not use it until all safety conditions have been met.
- In the event of tripping of circuits breakers or fuse failure, locate the malfunction and solve it before resetting the circuit breaker or replacing the fuse. If the malfunction is not repairable by consult this manual, contact a technician.
- Keep the operation area of the motorized gate free while the gate in in motion, and do not create strength to the gate movement.
- Do not perform any operation on mechanical elements or hinges if the product is in motion.

## RESPONSABILITY

- Supplier disclaims any liability if:
  - Product failure or deformation result from improper installation use or maintenance!
  - Safety norms are not followed in the installation, use and maintenance of the product.
  - Instructions in this manual are not followed.
  - Damaged is caused by unauthorized modifications
  - In these cases, the warranty is voided.

## SYMBOLS LEGEND:



• Important safety notices



• Useful information



• Programming information



• Potentiometer information



• Connectors information





• Buttons information

## 02. DIAGRAM

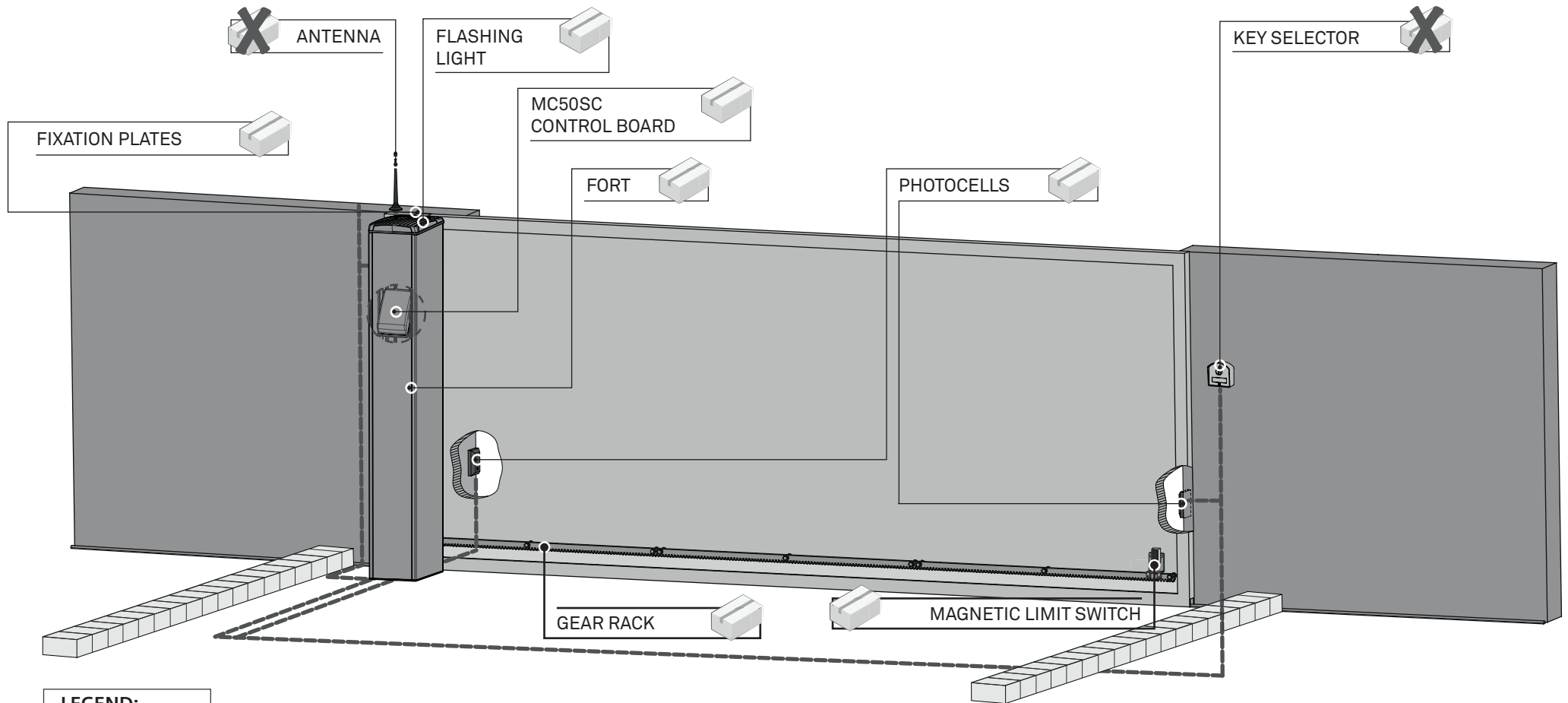
### MAP OF INSTALLATION



#### LEGEND:

- • Cables of connection
-  • Included in kit
-  • Optional



**It is important to use stoppers on the opening and closing of the gate.** If this is not respected, there may be danger of the gate open too much in manual mode and jump out of the rail.



All the cables must enter and exit from below the junction box and the control board box to ensure that all electrical connections are protected from contact with external elements (dust, insects, water, etc.). If necessary, apply silicone to ensure protection.

## 03. OPERATOR

### TECHNICAL SPECIFICATIONS

	FORT 24Vdc		FORT 230Vac
• Product power supply	110V 50/60Hz	230V 50/60Hz	230V 50/60Hz
• Motor voltage	24Vdc		230Vac
• Power	80W		90W
• Absorbed current	3 A		0,75 A
• RPM	2800 RPM		2800 RPM
• Noise	<65dB		<65dB
• Working temperature	-25° C to 55° C		-25° C to 55° C
• Thermal protection	-		120° C
• Protection grade	IP55		IP55
• Working frequency	intensive		80%
• Maximum leaf weight	400kg		

### DIMENSIONS

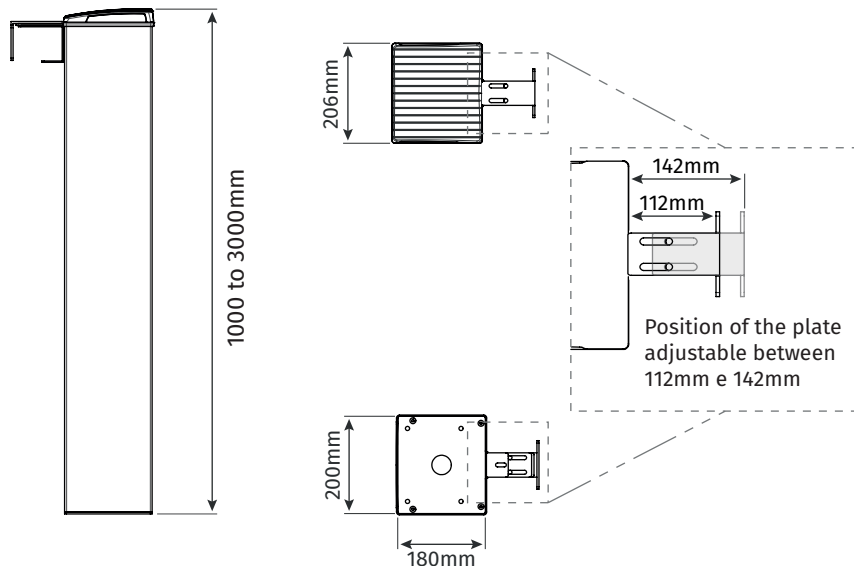

## 04. INSTALLATION

### UNLOCK THE MOTOR

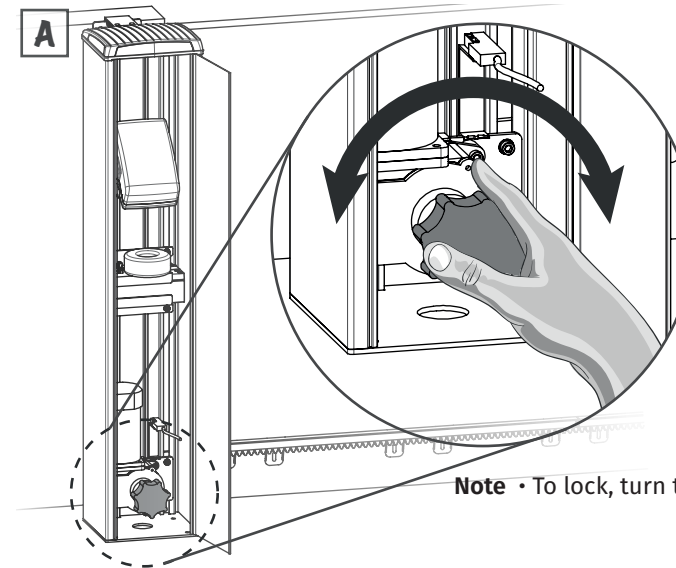

**01** • Open the FORT door using the key provided with the automatism. Inside, you will have access to the unlock system.

**02** • To unlock the motor press and turn the red piece. The direction of the rotation to unlock will depend on the position of the gate in its course (open or closed).

**Note** • To lock, turn the red piece again.

### PRE-INSTALLATION



To ensure full operation of the automatism, pay attention to the following recommendations:

- Read the entire manual at least once giving special attention to all notices marked with  $\triangle$ ;
- Check if the gate structure is sufficiently resistant;
- The gate should be very well leveled and have a uniform movement without irregular friction during the full course;
- The foundation to create (page 6A) should be very resistant to support the mounting screws of the plate;
- It is recommended that all locksmith works are carried out before proceeding with installation of the automatism;
- Check that the weight of the gate's leaf to be automated matches the value indicated in the motor's technical data (page 5A).

## 04. INSTALLATION

### CREATE FOUNDATION AND FIXING AUTOMATION

**B**

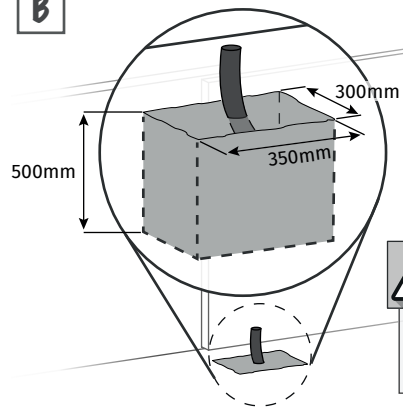

**01** • Make a hole in the ground to create a foundation in concrete. The dimensions shown are these recommended to create the foundation. You must leave tubes in the middle of the hole for the passage of cables for power and accessories.

**02** • Fill the hole with concrete and smooth the top where you will fix the engine.



For correct operation of the automatism, it is necessary to pay attention to the dimensions given in the following images. Also check if the fixation plate is parallel to the gate.

**C**

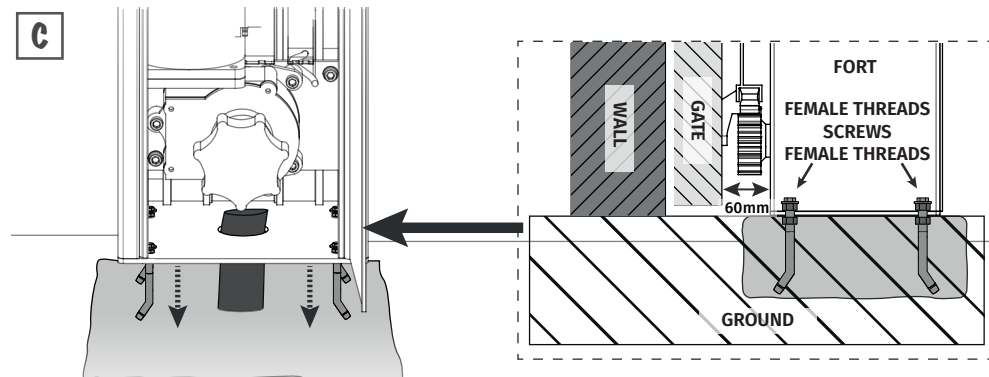

**03** • Fix the motor with the screws on the concrete base. Make sure the engine is level (use one level). Align the motor parallel to the gate, maintaining a distance of 60mm between them, as visible in the image.

**04** • Fix to the wall at the top of the automation.

**D**

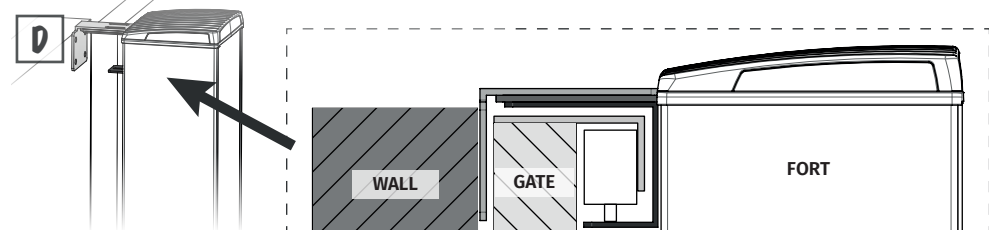

## 04. INSTALLATION

### FIXING AUTOMATION IN AN EXISTING FOUNDATION

If a foundation already exists at the installation area, proceed as follows:

**01** • Put the automation on top of the foundation and align it parallel to the gate keeping a distance of 60mm between them.

**02** • Mark the location to drill the bushings. Markings should be made in the center of the oval holes at the base of the automation.

**03** • Make the four holes in the foundation.

**04** • Insert the appropriate bushings into the holes.

**E**

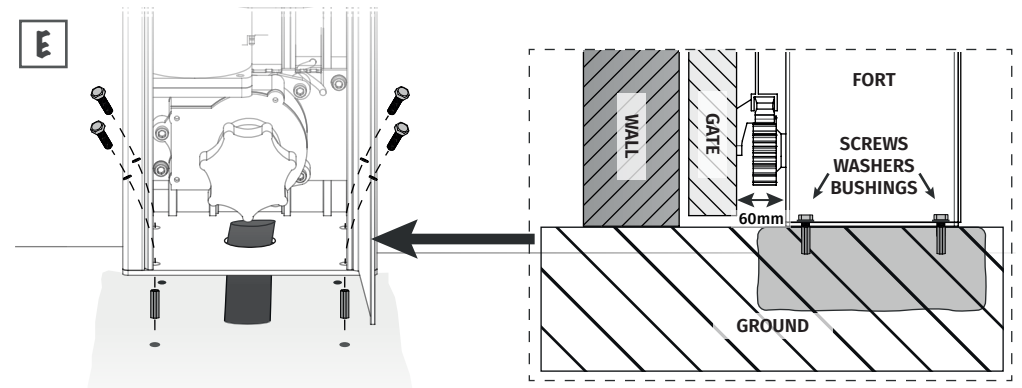

**05** • Place the automation on the concrete foundation respecting the distances indicated in the image. Level the automation horizontally with a level and tighten it with screws.

**06** • Fix to the wall at the top of the automation.

**F**

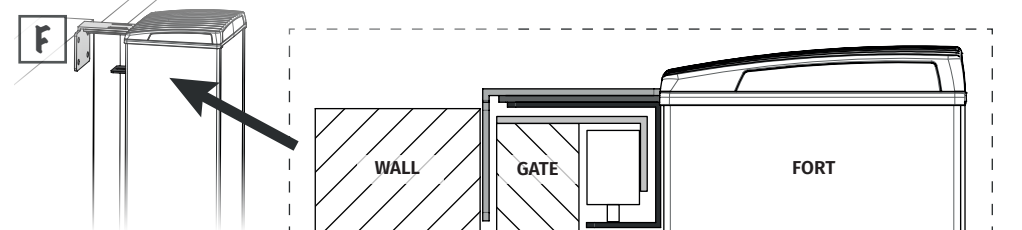



## 04. INSTALLATION

### METAL GEAR RACK INSTALLATION

Put the gate in the open position and unlock the motor (page 5B).

**01** • Place spacers in all the gear rack holes (G) to fix it to the gate. You should place them in the center of the ovalized rack holes, as shown in the image, so you can fine-tune them at the end of the installation if necessary.

**02** • Position a piece of gear rack over the pinion and level it horizontally with one level.

**03** • Solder the spacer over the pinion (H).

**04** • Close the gate a bit until the other end of the rack are supported on the pinion and weld the other spacer to the gate.

**05** • Close the gate slightly, letting the gear rack supported on the pinion and apply another piece of rack. To synchronize the teeth with the piece already installed, use an additional piece of rack and place it under the union of the other two, holding them with clamps (I).

**06** • Open the gate until the tip of the new gear rack it is supported on the pinion and weld the spacer.

**07** • Remove the auxiliary gear rack piece and open the gate until the pinion is over the other gear rack end. Weld the spacer.

**08** • Repeat the steps 5 through 7 for each meter of gear rack until you reach the end.

**09** • Test the gate movement manually already with all the gear racks installed and weld the remaining spacers. If there is any friction between the pinion and rack, adjust the rack on the oval bolts.



During the course of the gate, all elements of the gear rack must engage correctly with the pinion. Spacers can not be welded to the gear rack. Do not use grease or other type of lubricant between gear rack and pinion.

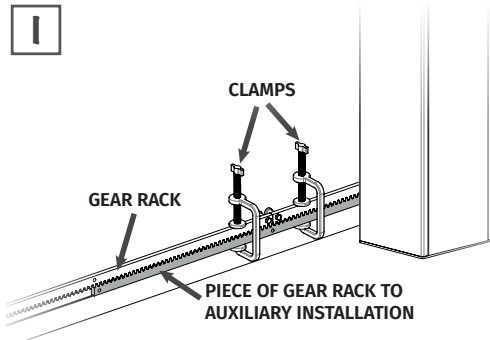
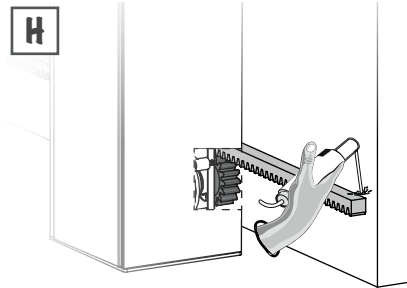

## 04. INSTALLATION

### NYLON GEAR RACK INSTALLATION

Put the gate in the open position and unlock the motor (page 5B).

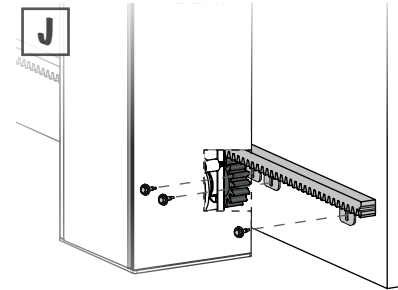

**01** • Position a piece of gear rack over the pinion and level it horizontally with one level.

**02** • Tighten the gear rack support to the gate, over the pinion.

**03** • Close the gate slightly until another end of the rack rests on the pinion and tighten the other bracket.

**04** • Close the gate slightly, letting the gear rack supported on the pinion. Apply another piece of gear rack by attaching it to the already screwed rack, as visible in the image detail (K).

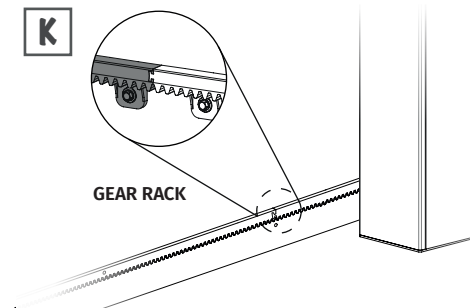

**05** • Open the gate until support the end of the new rack rests on the pinion and tighten it to the gate.

**06** • Open the gate until support the end of the other rack rests on the pinion and tighten it to the gate.

**07** • Repeat the steps for each meter of gear rack until you reach the end.



During the course of the gate, all elements of the gear rack must engage correctly with the pinion. All the supports should be screwed on the gate. Do not use grease or other type of lubricant between gear rack and pinion.



## 04. INSTALLATION

### APPLICATION OF THE MAGNETIC LIMIT SWITCH

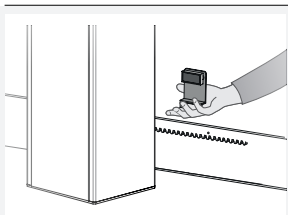

Before installing, you must identify the opening and closing limit switches. To do this, lock the motor and press the button to close the gate. During closure, pass one of the limit switches in the detection zone (as shown) to check if the gate stops. After identifying the limit, you can proceed with the installation.

#### MOTOR'S INSTALLATION IN THE RIGHT SIDE

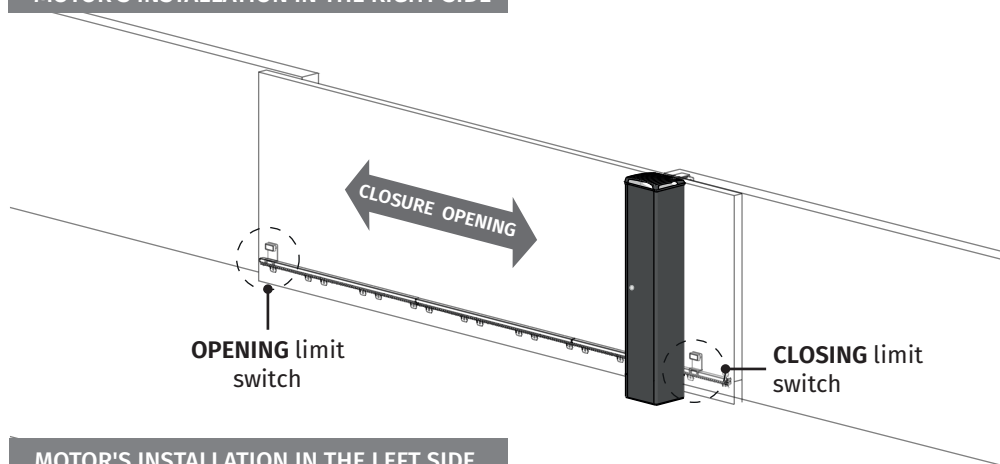

#### MOTOR'S INSTALLATION IN THE LEFT SIDE

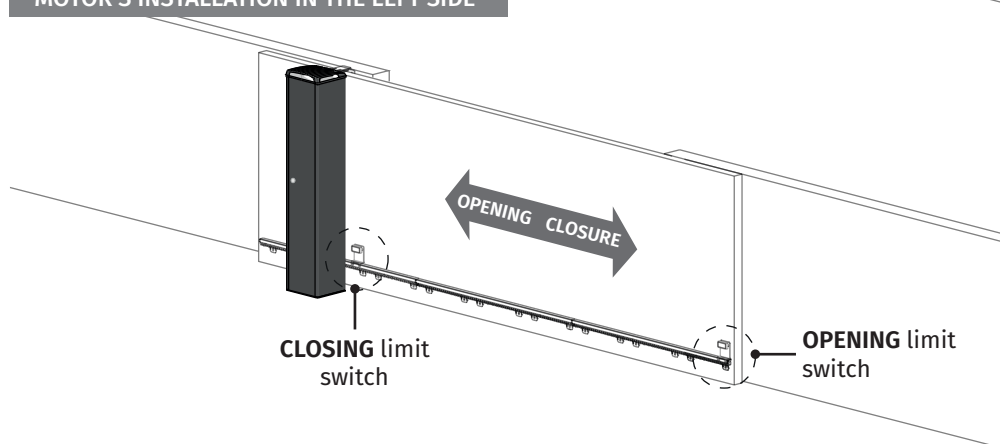

## 04. INSTALLATION

### APPLICATION OF THE MAGNETIC LIMIT SWITCH

Put the gate in the open position and unlock the motor (page 5B).



The limit switches must be adjusted for the gate to stop before touching the closing or opening stops. Manually test the limit switch with the door unlocked before turn the motor power on to avoid problems due to wrong configuration.

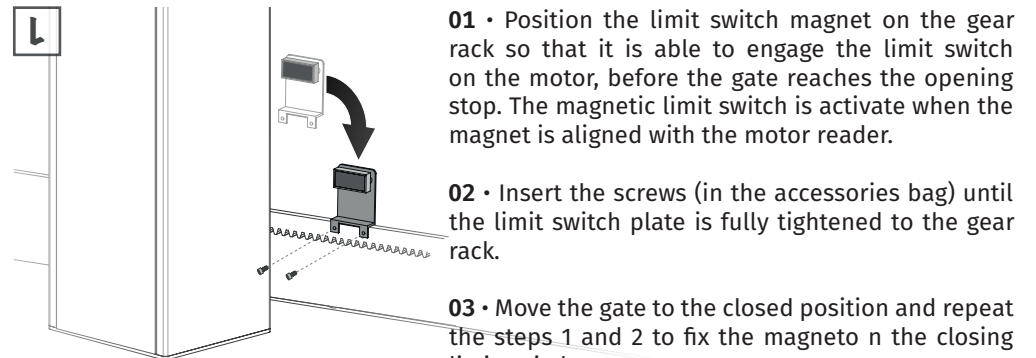

**01** • Position the limit switch magnet on the gear rack so that it is able to engage the limit switch on the motor, before the gate reaches the opening stop. The magnetic limit switch is activate when the magnet is aligned with the motor reader.

**02** • Insert the screws (in the accessories bag) until the limit switch plate is fully tightened to the gear rack.

**03** • Move the gate to the closed position and repeat the steps 1 and 2 to fix the magnet on the closing limit switch.

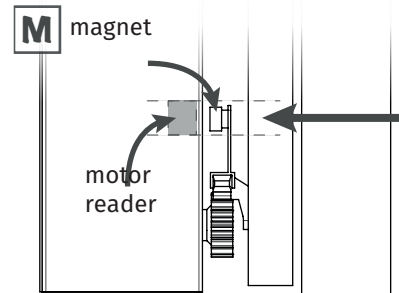

So that the magnetic limit switch can be engaged, the magnet must be aligned with the motor reader. Be careful to check if they are aligned when you are installing. This is the only way to ensure the successful operation for the limit switch.

## 05. MAINTENANCE

### MAINTENANCE

- Check all automation fixings.
- Make sure that the distance between the gear rack and the motor remains unchanged and if it engages on the teeth of the motor pinion correctly (over time, some distortion may occur).
- Lubricate all gate systems/axis. Lightly lubricate the pinion and the gear rack.

# 06. CONNECTION SCHEME

## 230V/110V MOTOR (MC50SC)

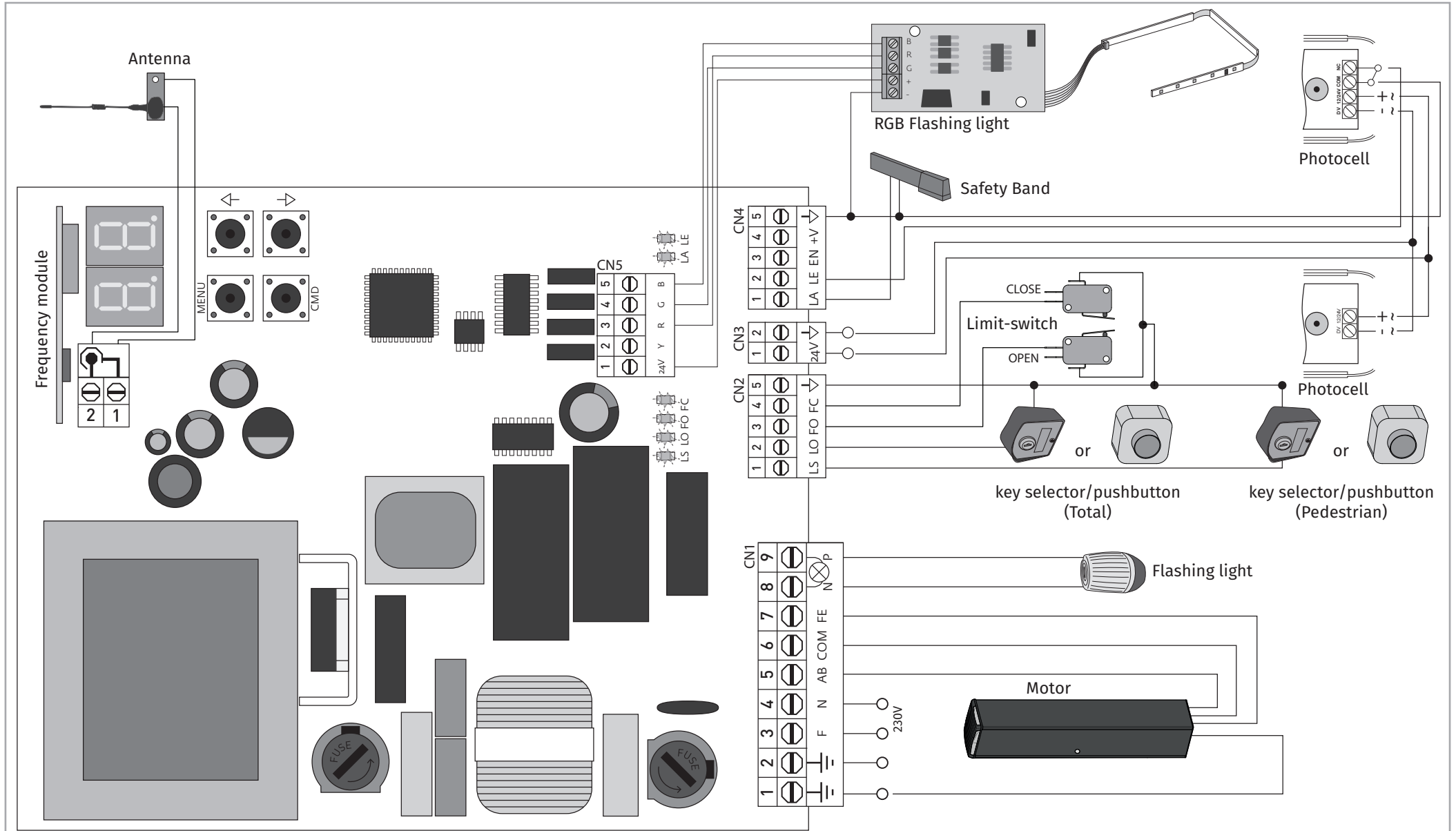

# 06. CONNECTION SCHEME

## 24V MOTOR (MC41SP)

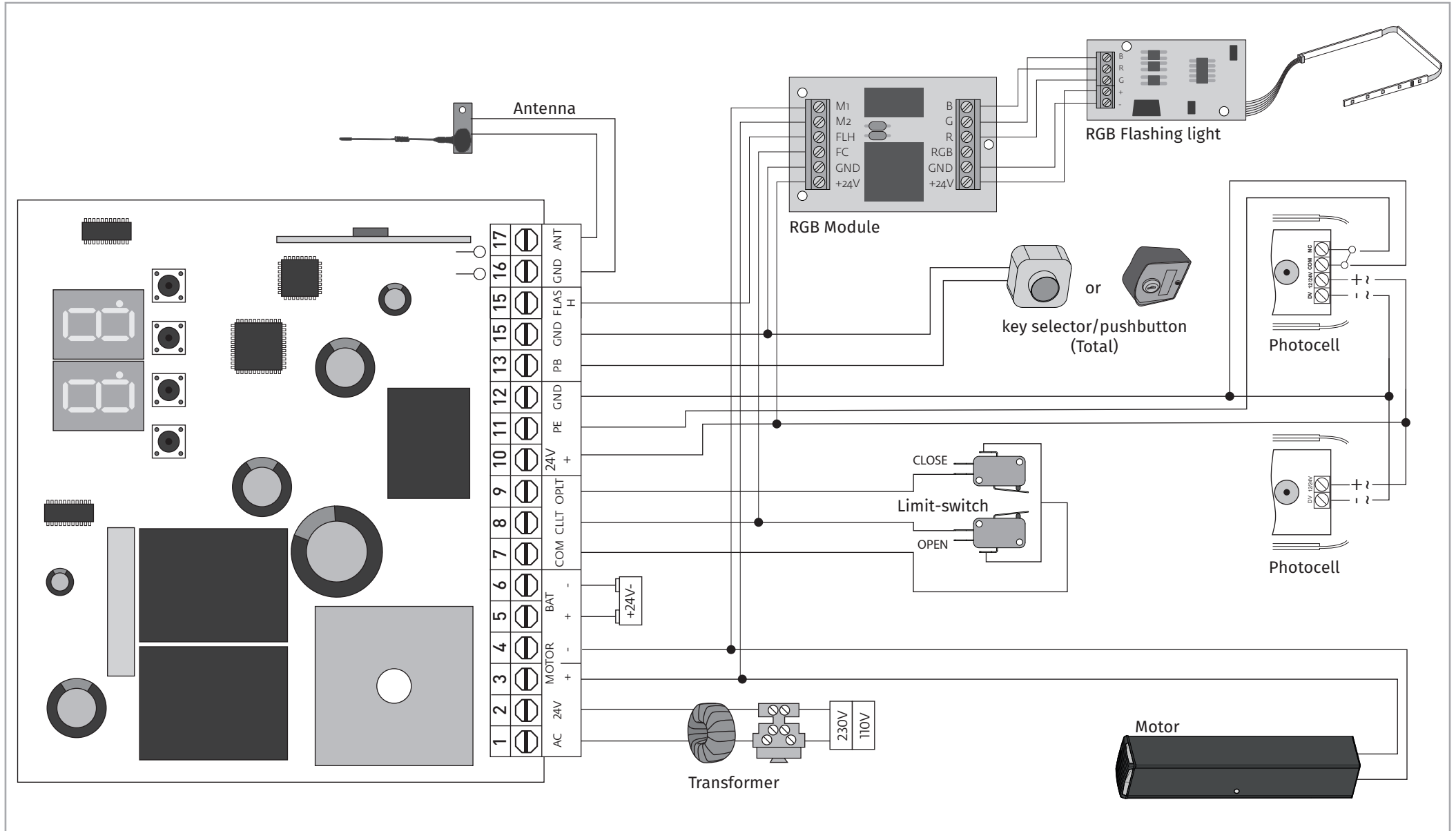

# 07. COMPONENTS TEST

## SCHEMES FOR TESTS

To detect if the failure is in the control board or in the motor, it is necessary to perform tests with a direct connection to a 230V or 24V power supply. In the diagrams below, it is shown how this connection should be made and how to interleave the different components wires.

### NOTES:

- To perform the tests, there is no need to remove the automatism from the place it is installed, because in this way, it is possible to understand if the automatism can function properly connected directly to the current.
- You should use a new capacitor during this test to ensure that the problem does not lie on it.

### FORT 230Vac

01 • Connect the power wires to the terminal, as shown below.

02 • Connect the automatism wires in the terminal, interposing a capacitor in the opening and closing wires.

03 • Once these connections are completed, connect to a 230Vdc power outlet.

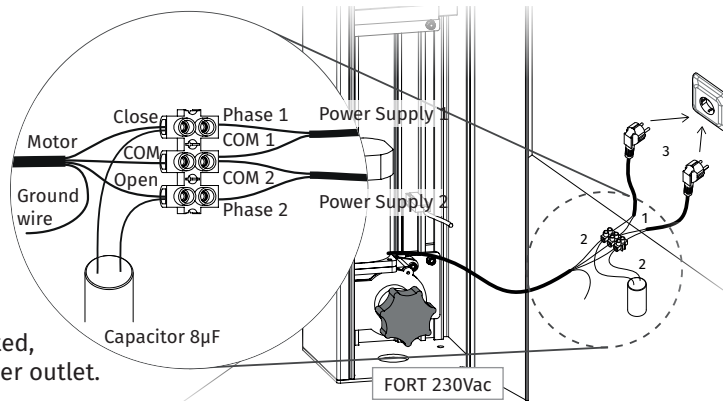

### FORT 24Vdc - test 1

Make the connections as shown in the picture. If the engine runs, the problem is in the control board. Changing the wires in the battery, changes the direction of movement of the motor/gate.

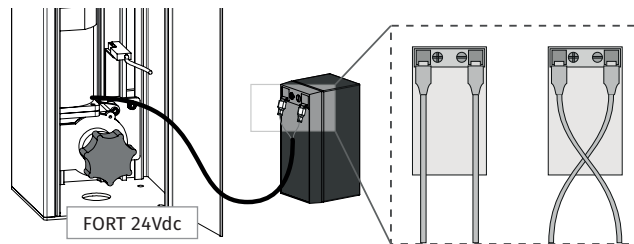

All tests must be performed by skilled technicians due to serious danger associated with the misuse of electrical systems!!

# 08. TROUBLESHOOTING

## FINAL CONSUMERS INSTRUCTIONS

## SPECIALIZED TECHNICIANS INSTRUCTIONS

Problem	Procedure	Behavior	Behavior II	Discovering the origin of the problem			
• Motor doesn't work	• Make sure you have 230V power supply connected to control board and if it is working properly.	• Still not working	• Consult a qualified technician.	1 • Open control board and check if it has power supply; 2 • Check input fuses of the control board;	3 • Disconnect the motor from control board and test them by connecting directly to power supply in order to find out if they have problems (see page 11A).	4 • If the motor works, problem is on the control board. Pull it out and send it to our <b>MOTORLINE</b> technical services for diagnosis;	5 • If the motor doesn't work, remove them from installation site and send to our <b>MOTORLINE</b> technical services for diagnosis.
• Motor doesn't move but makes noise	• Unlock motor and move the gate by hand to check for mechanical problems on the gate.	• Found problems?	• Consult a qualified gates technician.	1 • Check motion axis and associated motion systems related with the motor (wheels, gear racks, etc.) to find out what is the problem.			
		• The gate moves easily?	• Consult a qualified <b>MOTORLINE</b> technician.	1 • Check capacitor, testing operator with a new one;	2 • If capacitors are not the problem, disconnect motor from control board and it them by connecting directly to power supply in order to find out if it has problems (see page 7B);	3 • If the motor works, the problem is from control board. Pull it out and send it to our <b>MOTORLINE</b> technical services for diagnosis;	4 • If the motor doesn't work, remove them from installation site and send to our <b>MOTORLINE</b> technical services for diagnosis.
• Motor opens but doesn't close	• Unlock motor and move the gate by hand to closed position. Lock motor again and turn of power supply for 5 seconds. Reconnect it and send order to open gate using transmitter.	• Gate opened but didn't close again.	1 • Check if there is any obstacle in front of the photocells; 2 • Check if any of the control devices (key selector, push button, video intercom, etc.) of the gate are jammed and sending permanent signal to control unit; 3 • Consult a qualified <b>MOTORLINE</b> technician.	All <b>MOTORLINE</b> control boards have LEDs that easily allow to conclude which devices are with anomalies. All safety devices LEDs (DS) in normal situations remain On. All "START" circuits LEDs in normal situations remain Off.  If LEDs devices are not all On, there is some security systems malfunction (photocells, safety edges), etc. If "START" circuits LEDs are turn On, there is a control device sending permanent signal	<b>A) SECURITY SYSTEMS:</b> 1 • Close with a shunt all safety systems on the control board (check manual of the control board in question). If the automated system starts working normally check for the problematic device. 2 • Remove one shunt at a time until you find the malfunction device 3 • Replace it for a functional device and check if the motor works correctly with all the other devices. If you find another one defective, follow the same steps until you find all the problems.	<b>B) START SYSTEMS:</b> 1 • Disconnect all wires from START terminal input. 2 • If the LED turned Off, try reconnecting one device at a time until you find the defective device.  <b>NOTE:</b> In case procedures described in sections A) and B) don't result, remove control board and send to the <b>MOTORLINE</b> technical services for diagnosis;	
• Motor doesn't make full course	• Unlock motor and move the gate by hand to check for mechanical problems on the gate.	• Found problems?	• Consult a qualified gates technician	1 • Check motion axis and associated motion systems related with the motor (wheels, gear racks, etc.) to find out what is the problem.			
		• The gate moves easily?	• Consult a qualified <b>MOTORLINE</b> technician	1 • Check capacitor, testing operator with a new one; 2 • If capacitors are not the problem, disconnect motor from control board and test it by connecting directly to power supply in order to find out if it is broken; 3 • If the motor doesn't work, remove them from installation site and send to our <b>MOTORLINE</b> technical services for diagnosis.	4 • If motor work well and move gate at full force during the entire course, the problem is from controller. Set force using trimmer on the board. Make a new working time programming, giving sufficient time for opening and closing with appropriate force . 5 • If this doesn't work, remove control unit and send it to <b>MOTORLINE</b> technical services.	<b>NOTE:</b> Setting force of the controller should be sufficient to make the gate open and close without stopping, but should stop and invert with a little effort from a person. In case of safety systems failure, the gate shall never cause physical damaged to obstacles (vehicles, people, etc).	