

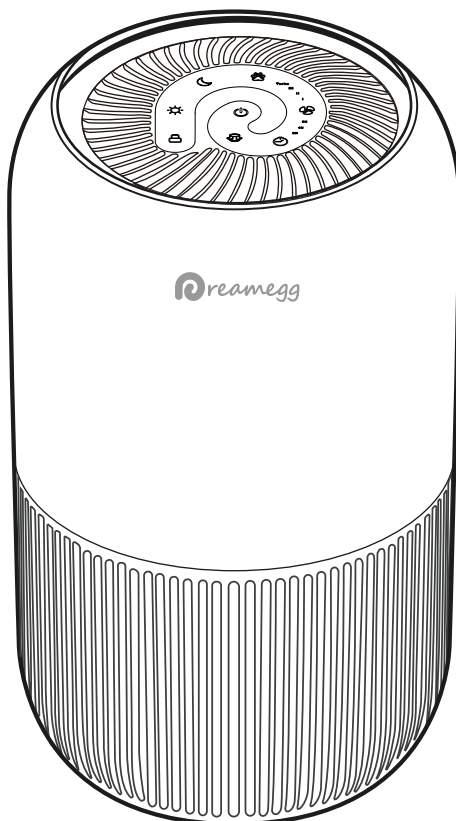

USER MANUAL

True HEPA Air Purifier

Model: TR-8080



Questions or Concerns?

Dreamegg Support provides friendly services in 24 hours. Please contact us Mon-Sat at [✉ support@mydreamegg.com](mailto:support@mydreamegg.com) if you need any help.

PROTECT YOUR WARRANTY

Thank you for your purchase! Your unit comes with 18 months warranty (one year and an additional 6 months by registering on our website – no cost to you!) and 60 days money back guarantee.

Activate Your Warranty

To activate your warranty and register your new Dreamegg, please scan the QR code below or go to the website to complete the information.

REGISTER NOW–FREE!



or

dreamegg.com/pages/warranty-extension

Get

Table of Contents

Package Contents	3
Specifications	3
Safety Instructions	3
Getting to Know Your Air Purifier	5
Controls	6
Getting Started	6
Using Your Purifier	7
About the Filter	9
Care & Maintenance	11
Troubleshooting	12
Warranty Information	14
Customer Support	14

Package Contents

1 x	Air Purifier
1 x	True HEPA Filter (Pre-Installed)
1 x	User Manual

Specifications

Power Supply	AC 120V,60Hz
Rated Power	30W
Operating Conditions	Temperature: 14°–104°F / –10°–40°C
	Humidity: < 85% RH
Noise Level	23–50dB
Standby Power	< 0.5W
Dimensions	7.9 x 7.9 x 13.3 in / 20 x 20 x 34 cm
Weight	5.5lb / 2.5 kg

READ AND SAVE THESE INSTRUCTIONS

SAFETY INSTRUCTIONS

Failure to comply with the warnings listed below may result in electric shock or serious injury.

This product should only be used in accordance with the specifications outlined in this manual. Usage other than what has been specified here may result in serious injury.

When using electrical appliances, the following basic precautions should always be taken to reduce the risk of fire, electric shock and injury to persons. Read all instructions before using appliance.

- **IMPORTANT** – This appliance has a polarized plug (one blade is wider than the other). To reduce the risk of electric shock, this plug is intended to fit in a polarized outlet only one way. If the plug does not fit fully in the outlet, reverse the plug. If it still does not fit, contact a qualified electrician. Do not attempt to defeat this safety feature.
- To avoid fire or shock hazard, plug the appliance directly into a correct AC electrical outlet.
- Keep the cord out of heavy traffic areas. To avoid fire hazard, NEVER put the cord under rugs, or near radiators, stoves or heaters.
- To protect against electrical hazards, DO NOT immerse in water or other liquids, and do not use near water.
- As children are not able to recognize the hazards associated with the usage of electrical appliances, always supervise children when they are near the unit.
- Always unplug the air purifier before moving it, opening the grill, changing filters, cleaning, or whenever the air purifier is not in use. Be sure to unplug it by pulling on the plug and not the cord.
- NEVER drop or insert any object into any openings.
- DO NOT run cord under carpeting.
- DO NOT cover cord with throw rugs, runners, or similar coverings.
- DO NOT route cord under furniture or appliances. Arrange cord away from traffic areas where it will not present a tripping hazard.
- DO NOT operate any appliance with a damaged cord or plug, if the motor fails to rotate, after the appliance malfunctions, or if it has been dropped or damaged in any manner. Get support from Customer Service for maintenance and repairs.
- Use appliance only for intended household use as described in this manual. Any other use not recommended by the manufacturer may cause fire, electric shock or injury to persons.
- DO NOT use outdoors.
- DO NOT place anything on top of the unit.
- NEVER block the air openings, grills, outlets, or place on a soft surface such as a bed or sofa, as this could cause the unit to tip over, blocking the air intake or outlet opening.
- DO NOT attempt to repair or adjust any electrical or mechanical functions on this unit. Doing so will void your warranty. The inside of the unit contains no user serviceable parts. All servicing should be performed by qualified personnel only.
- **WARNING:** To reduce the risk of fire or electric shock, do not use this fan with any solid-state speed control device.

GETTING TO KNOW YOUR AIR PURIFIER

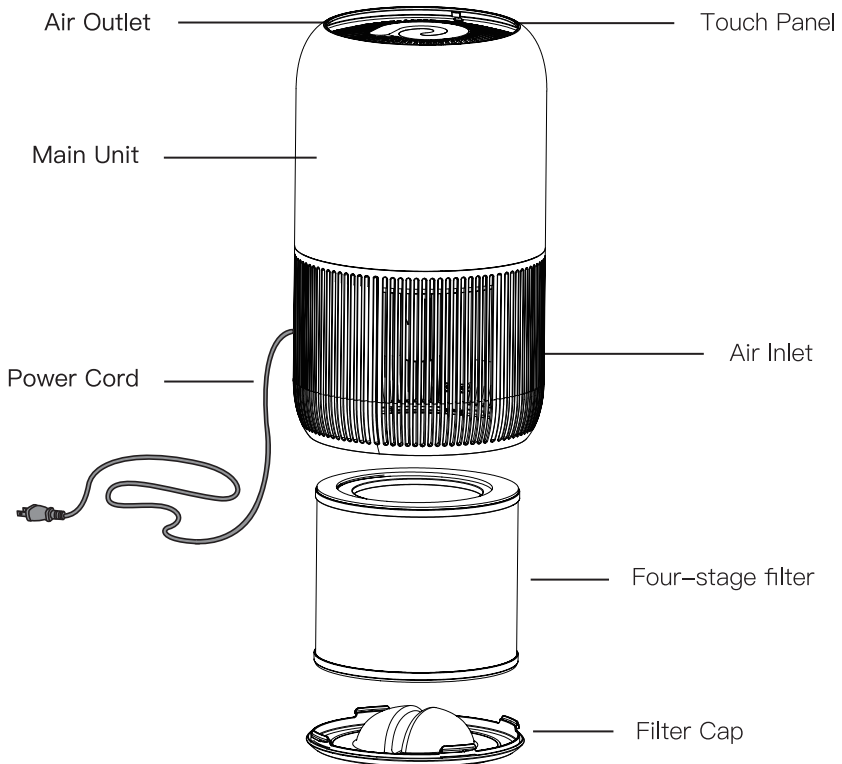
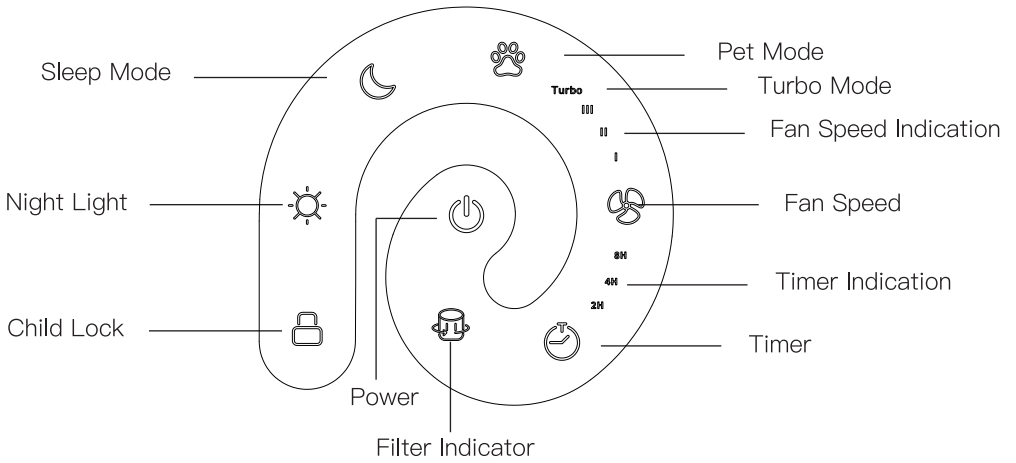

CONTROLS



On/Off Button

- Turns the air purifier on/off.



Night Light Button

- Turns the night light on/off (see page 7).



Fan Speed Button

- Cycles through fan speeds: I (low), II (medium), III (high) and Turbo speed.



Filter Indicator

- Lights up when the filter should be checked (see **Check Filter Indicator** page 10).



Sleep Mode Button

- Turns Sleep Mode on/off (see page 8).



Pet Mode

- Run with turbo speed for 15min then Level III speed for 5 min, and back to original settings, quickly deodorizes and purifies air.



Timer Button

- Cycles through timer options (see page 8).



Child Lock

- Prevent children and pets from accidentally tampering with it.

GETTING STARTED

1. Flip over the air purifier. Twist the filter cover cap counterclockwise to remove it and set it aside.
2. Lift the filter cover off the purifier.
3. Remove the filter from its plastic packaging and place the filter back into the purifier.

Note: The filter does not have a top or bottom and can be installed either way.

4. Replace the filter and cover the cap. Twist the cap clockwise to lock.
5. Place the purifier on a flat, stable surface with the display facing up. Allow at least 15 in / 38cm of clearance on all sides of the purifier. Keep away from anything that would block air flow, such as curtains.

USING YOUR PURIFIER

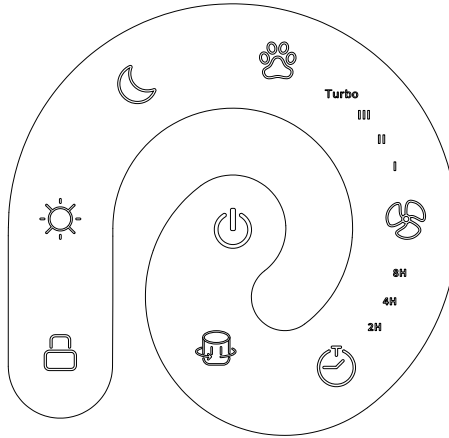

POWER ON/OFF

Slightly touch this button to turn on or switch off the unit.

FAN SPEED

Tap the fan button to change fan speed between I, II, III and turbo.

- Turbo Fan Setting is the loudest but purify air quickest.
- To effectively purify air, please keep windows and doors closed while operating the air purifier.

Pet Mode

Run with turbo speed for 15min then Level III speed for 5 min, and back to original settings, quickly deodorizes and purifies air.

- To exit pet mode: Touch this Pet button or fan button, the unit will be back to your previous settings.

Night light

1. Tap once, it turns in full brightness.
2. Tap a second time, it turn in dim brightness.
3. Tap a third time, it turns off.



Sleep Mode

- 1.Touch this button to turn on sleep mode, all light indicator flash 3 times and then goes off.
- 2.At sleep mode, it operates quietly by using the lowest possible fan speed.
- 3.Touch this button or any other button to exit sleep mode. It will be back to your previous settings.

Note:

- All indicators and night light will turn off when in Sleep Mode.
- The air purifier will automatically turn off if you set any timer.
- Sleep mode will not be remembered after re-plugging the unit.



Timer

- 1.Tap this button repeatedly to select a timer from 2, 4, 8 hours.
- 2.The air purifier will automatically power off once the timer is finished.
- 3.To cancel a timer, tap until all timer indicators are off, the unit will run continuously.

Run Continuously

Touch the button repeatedly until there are no more indicator lights lit up, it means you are in continuous mode.



Child Lock

- 1.Hold and Press the button for 2.5s to turn on/off the child lock function.
- 2.When child lock function is activated, all modes can not be changed.

Note:

- When the unit is in sleep mode, tapping the child lock button will not activate the lock function. It will cancel sleep mode first, then you need to long press around 2.5s to activate the child lock.



Filter Replacement Indicator

- 1.The filter light will light up yellow as a reminder to check & replace the filter.
- 2.The indicator should turn on Yellow within 6 months (4320 hours) continuous using, depending on how much you use the air purifier.

ABOUT THE FILTER

The air purifier uses a 4-stage filtration system to purify air.

A. Pre-Filter

- Captures large particles such as dust, lint, fibers, hair, and pet fur.
- Maximizes the filter's life.

B. STERILIZATION FILTER

- Since it contains a component that suppresses the growth of bacteria and viruses, it removes bacteria and viruses in the filtered air.

C. True HEPA Filter

- Removes at least 99.97% of airborne particles 0.1 micrometers (μm) in diameter.
- Filters small particles such as smoke, tiny dust particles, mold spores, bacteria, viruses, and allergens such as pollen, dander, and mites.

D. High-Efficiency Activated Carbon Particles

- Physically adsorbs unwanted odors and fumes.
- Filters compounds such as formaldehyde, benzene, ammonia, hydrogen sulfide, and volatile organic compounds (VOCs).

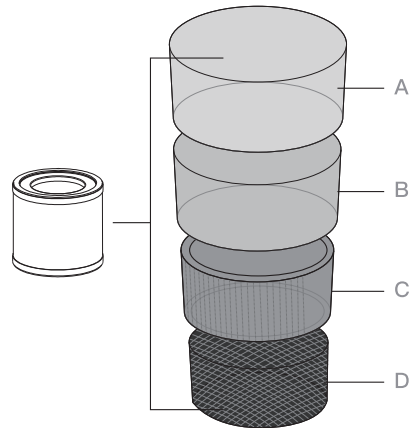

Humidity

Moisture may damage the filters. This air purifier should be used in an area with a humidity level below 85% RH. If you use the air purifier in excessively humid areas, the surface of the filter will become moldy.

Note: Water or moisture will allow mold to grow. Air purifiers cannot solve an existing mold problem, only remove mold spores and reduce odors.

Essential Oils

Do not add essential oils to the air purifier or filter. The filter will become damaged by the oil and will eventually release an unpleasant smell. **Do not** use oil diffusers near the purifier.



When Should I Replace the Filter?

A. When you found the  lights up, it is a reminder that you need to replace with a new filter.

B. You can also replace with a new filter even if the  doesn't light up for better performance, especially you are using your air purifier in an environment with relatively high pollution. You may need to replace your filter if you notice:

1. Increased noise when the air purifier is on
2. Decreased airflow
3. Unusual odors
4. A visibly clogged filter

How to Replace the Filter and Reset the .

1. Unplug the air purifier. Flip the air purifier over and remove the filter cap (see **Getting Started** , page 6).
2. Remove the old filter.
3. Unwrap the new filter and place it into the housing (see **Getting Started** , page 6).
4. Replace the cover and cap. Plug in the air purifier.
5. Reset the .
6. After replacing the filter, you need to plug in the air purifier and long press the  for 2.5S, then the light will disappear and the machine will automatically calculate the usage hours from now on.

CARE & MAINTENANCE

Cleaning the Air Purifier

- Unplug before cleaning.
- Wipe the outside of the air purifier with a soft, dry cloth. If necessary, wipe the housing with a damp cloth, then immediately dry.
- Vacuum the inside of the air purifier.
- **Do not** clean with abrasive chemicals or flammable cleaning agents.



Cleaning the Filter







The True HEPA Filter should be cleaned once a month to increase the efficiency and extend the life of your filter. Clean the inside and outside of the filter using a soft brush or vacuum hose to remove hair, dust, and large particles. **Do not** clean the filter with water or other liquids.

Storage

If not using the air purifier for an extended period of time, wrap both the purifier and the filter in plastic packaging and store in a dry place to avoid moisture damage.

TROUBLESHOOTING

Problem	Possible Solution
Air purifier will not turn on or respond to button controls.	Plug in the air purifier.
	Check to see if the power cord is damaged. If so, stop using the air purifier and contact Customer Support (see page 14).
	Plug the air purifier into a different outlet.
	Air purifier is malfunctioning. Contact Customer Support (see page 14).
Airflow is significantly reduced.	Make sure the filter is removed from its packaging and properly in place (see page 6).
	Tap  to increase the fan speed.
	Make sure there are at least 15 in / 38 cm of clearance on all sides of the air purifier.
	Replace the filter (see page 10).
Air purifier makes an unusual noise while the fan is on.	Make sure the filter is properly in place with plastic packaging removed (see page 6).
	Make sure the air purifier is operating on a hard, flat, even surface.
	Replace the filter (see page 10).
	The air purifier may be damaged, or a foreign object may be inside. Stop using the air purifier and contact Customer Support (see page 14). Do not try to repair the air purifier.
Poor air purification quality.	Tap  to increase the fan speed.
	Make sure no objects are blocking the sides or top of the air purifier (the inlet or outlet).
	Make sure the filter is removed from its packaging and properly in place (see page 6).
	Close doors and windows while using the air purifier.
	The purifier works best in room around 215ft ² /20m ² . It may not be as effective in rooms > 269ft ² /25m ² .
	Replace the filter (see page 10).

<p>Strange smell coming from the purifier.</p>	<p>Clean the filter or replace if necessary.</p> <p>Contact Customer Support (see page 14).</p> <p>Make sure not to use your purifier in an area with high humidity or while diffusing essential oils.</p>
<p> is still on after replacing the filter.</p>	<p>Reset the Filter Reset Indicator (see page 10).</p>
<p> has not turned on within 8 months.</p>	<p> is a reminder for you to check the filter and will light up based on how long the air purifier has been used (see page 10). If you don't use your air purifier often,  will take longer to turn on.</p>
<p> turned on before 6 months.</p>	<p> is a reminder for you to check the filter and will light up based on how long the air purifier has been used (see page 10). If you run your air purifier frequently,  will turn on sooner.</p>
<p>Air does not flow evenly out of the air purifier.</p>	<p>This is due to the design of the air purifier. This is normal and will not affect the air purifier's efficiency.</p>

If your problem is not listed, please contact **Customer Support** . (see page 14).

WARRANTY INFORMATION

Defective Products & Returns

1. Would love a replacement for defective products?

Should your product be defective within the specified warranty period, please contact us via  support@mydreamegg.com with order number. Once our customer support team hears from you, we will process your request in 24 hours.

2. Not happy with the unit or passed Amazon 30 days return window?

No worries! Be sure to contact Dreamegg customer service at  support@mydreamegg.com with your order number. We will process your request faster and easier, usually in 24 hours.

CUSTOMER SERVICE

 support@mydreamegg.com

Need help? Contact us directly at support@mydreamegg.com with your order ID. We are more than happy to serve you in 24 hours. Dreamegg support is here to make sure you are completely satisfied with your product.



Dreamegg