

EFFECTIVE:  
12-MAY-11

# HORIZONTAL MOTORS

UNIMOUNT WITH "C" BRACKET W/ OVERSIZE OUTLET BOX

PRINT:  
07-2872-01

SUPERSEDES:  
21-DEC-10

FRAME: 213-215 TC  
BASIC TYPE: UT

SHEET:  
1 OF 1

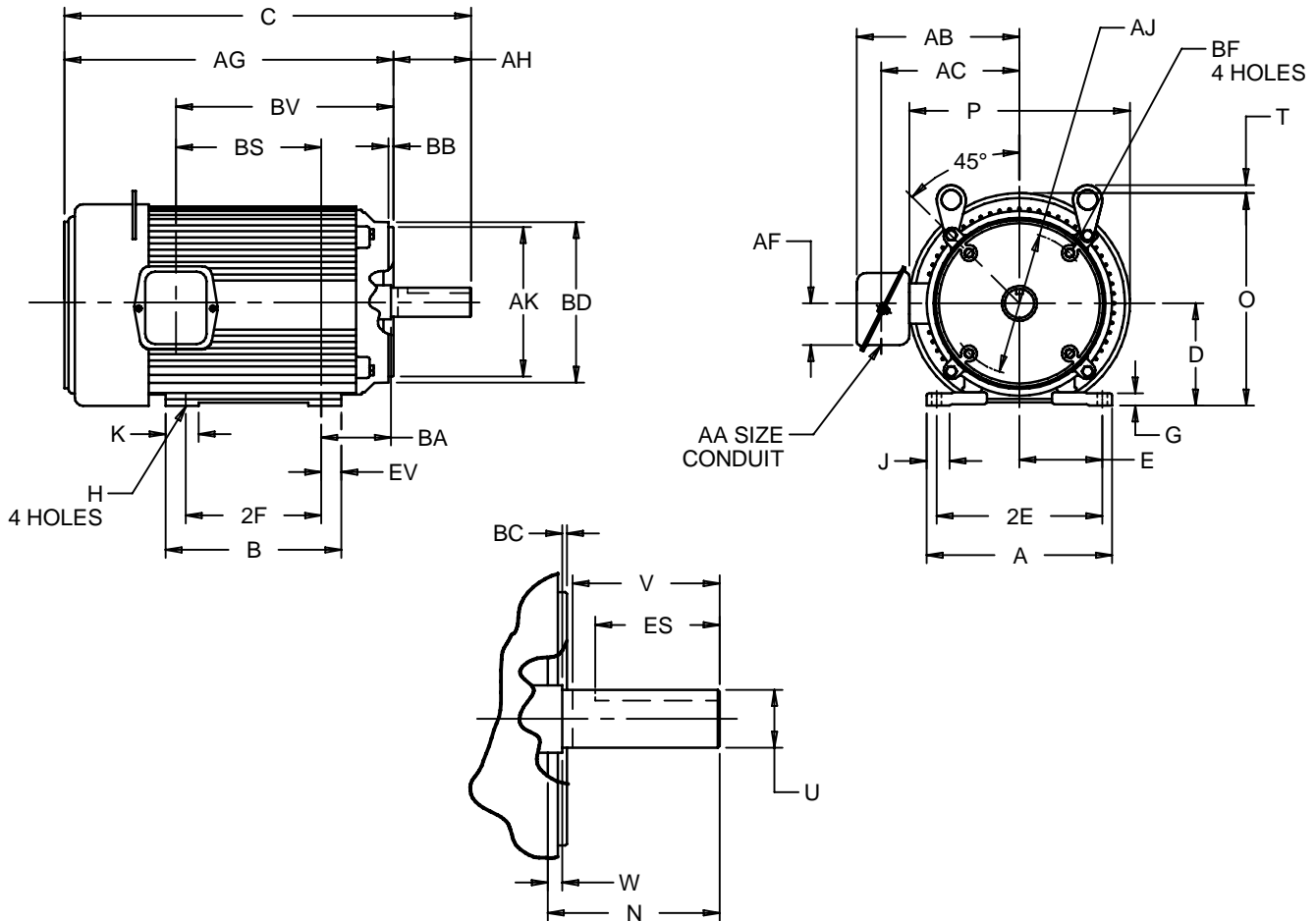

ALL DIMENSIONS ARE IN INCHES AND MILLIMETERS

UNITS	A	D -.06	E	2E ±.03	G	H +.05	J	K	N	O	P <sup>2</sup>	T	U -.0005	V MIN	W
IN	9.50	5.25	4.25	8.50	.63	.41	1.16	1.56	3.50	10.88	11.25	.38	1.3750	3.09	.13
MM	241	133	108	216	16	10	29	40	89	276	286	10	34.925	78	3

UNITS	AA	AB	AC	AF	AH	AJ	AK -.003	BA	BB MIN	BC	BD MAX	BF <sup>7</sup>	ES MIN	EV	SQ KEY
IN	1.00	8.78	7.13	2.63	3.13	7.250	8.500	4.25	.25	.25	9.00	1/2-13 x .75	2.41	.94	.313
MM		223	181	67	80	184.15	215.90	108	6	6	229		61	24	7.95

FRAME	UNITS	B	C	2F	AG	BS	BV
213TC	IN	7.38	18.75	5.50	15.63	5.13	9.94
	MM	187	476	140	397	130	252
215TC	IN	8.88	20.25	7.00	17.13	6.63	11.44
	MM	226	514	178	435	168	291

TOLERANCES	
FACE RUNOUT	.004 T.I.R.
PERMISSIBLE ECCENTRICITY OF MOUNTING RABBET	.004 T.I.R.
PERMISSIBLE SHAFT RUNOUT	.002 T.I.R.

1: ALL ROUGH CASTING DIMENSIONS MAY VARY BY .25" DUE TO CASTING AND/OR FABRICATION VARIATIONS.  
2: LARGEST MOTOR WIDTH.  
3: FRAME REFERENCE: 9.500"/213//11.000"/215

4: CONDUIT BOX MAY BE LOCATED ON EITHER SIDE OF MOTOR. CONDUIT OPENINGS MAY BE LOCATED IN STEPS OF 90 DEGREES REGARDLESS OF LOCATION. STANDARD AS SHOWN WITH CONDUIT OPENING DOWN.  
5: TOLERANCES SHOWN ARE IN INCHES ONLY.  
6: ALL TAPPED HOLES ARE UNIFIED NATIONAL COARSE, RIGHT HAND THREAD.  
7: TAP SIZE AND BOLT PENETRATION ALLOWANCE.

07-2872/B

**Nidec Motor Corporation**  
St. Louis, Missouri

INFORMATION DISCLOSED ON THIS DOCUMENT IS CONSIDERED PROPRIETARY AND SHALL NOT BE REPRODUCED OR DISCLOSED WITHOUT WRITTEN CONSENT OF NIDEC MOTOR CORPORATION



ISSUED BY  
**L. CUESTA**  
APPROVED BY  
**J. MAGALLANES**

IHP\_DP\_NMCA (MAR-2011) SOLIDEDGE