

EFFECTIVE:
03-MAY-12

SUPERSEDES:
03-MAY-12

VERTICAL MOTORS
WEATHER PROTECTED
FRAME: 182, 184VP
BASIC TYPE: AV,AVE

PRINT:
09-2956

SHEET:
1 OF 1

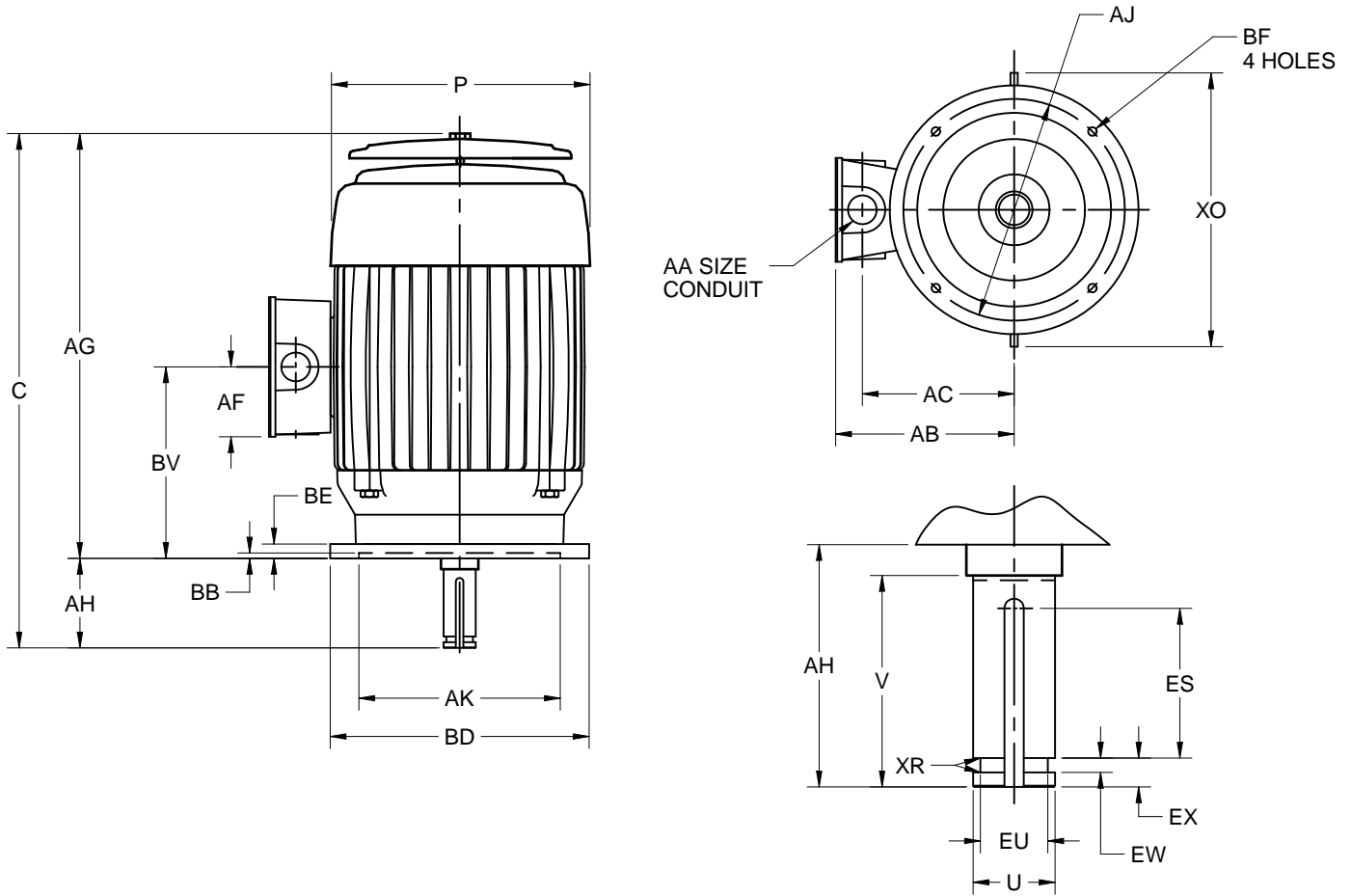

| UNITS | C | P ³ | U -.0005 | V MIN | AA | AB | AC | AF | AG | AH ⁶ -.062 | AJ | AK +.003 |
|-------|-------|----------------|-------------|----------|------|------|------|------|-------|--------------------------|--------|-------------|
| IN | 18.94 | 9.50 | 1.1250 | 2.75 | 1.00 | 7.31 | 6.16 | 2.63 | 16.19 | 2.750 | 9.125 | 8.250 |
| MM | 481 | 241 | 28.575 | 70 | | 186 | 156 | 67 | 411 | 69.85 | 231.78 | 209.55 |

| UNITS | BB MIN | BD MAX | BE | BF ² | BV | ES MIN | EU -.005 | EW +.002 | EX -.005 | XO | XR | SQ KEY |
|-------|-----------|-----------|-----|-----------------|------|-----------|-------------|-------------|-------------|-------|-----|-----------|
| IN | .25 | 10.00 | .75 | .44 | 7.25 | 1.25 | .875 | .375 | .750 | 11.94 | .03 | .250 |
| MM | 5 | 254 | 19 | 11 | 184 | 32 | 22.23 | 9.53 | 19.05 | 303 | 1 | 6.35 |

1. ALL ROUGH CASTING DIMENSIONS MAY VARY BY .25" DUE TO CASTING VARIATIONS.
2. TAP SIZE AND BOLT PENETRATION ALLOWANCE.
3. LARGEST MOTOR WIDTH.
4. TOLERANCES SHOWN ARE IN INCHES ONLY.
5. CONDUIT OPENINGS MAY BE LOCATED IN STEPS OF 90 DEGREES. STANDARD AS SHOWN WITH CONDUIT OPENING DOWN.
6. DIMENSION MEASURED WITH MOTOR IN VERTICAL POSITION, SHAFT DOWN.

| TOLERANCES | |
|---|-------------|
| FACE RUNOUT | .004 T.I.R. |
| PERMISSIBLE ECCENTRICITY OF MOUNTING RABBET | .004 T.I.R. |
| PERMISSIBLE SHAFT RUNOUT | .002 T.I.R. |

09-2956/A

Nidec Motor Corporation
St. Louis, Missouri

INFORMATION DISCLOSED ON THIS DOCUMENT IS CONSIDERED PROPRIETARY AND SHALL NOT BE REPRODUCED OR DISCLOSED WITHOUT WRITTEN CONSENT OF NIDEC MOTOR CORPORATION



ISSUED BY
E. AYALA
APPROVED BY
E. LUNA

IHP_DP_NMCA (MAR-2011) SOLIDEDGE