

EFFECTIVE:
27-AUG-15

SUPERSEDES:
11-APR-11

DIMENSION PRINT

TEAO

FRAME: 250T
BASIC TYPE: CTN

PRINT:
07-2837

SHEET:
1 OF 1

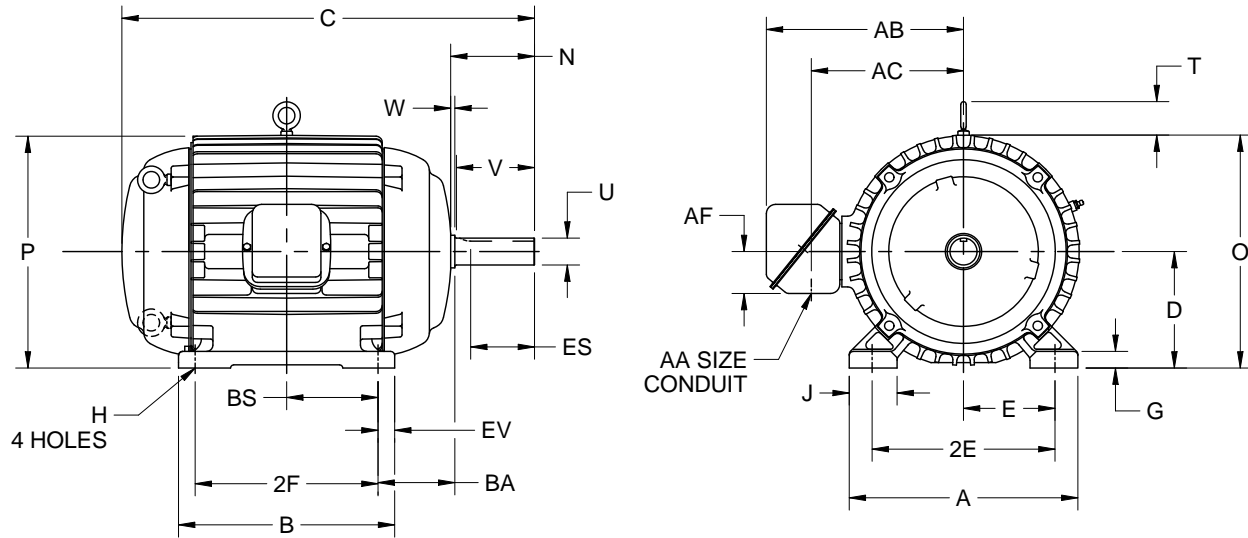

ALL DIMENSIONS ARE IN INCHES AND MILLIMETERS

UNITS	A	B	C	D -.06	E	2E ±.03	G	H +.05	J	N	O
IN	12.13	12.00	22.13	6.25	5.00	10.00	.88	.53	2.25	4.38	12.91
MM	308	305	562	159	127	254	22	13	57	111	328

UNITS	P ²	T	U -.001	V MIN	W	AA	AB	AC	AF	BA	BS
IN	14.22	2.03	1.625	3.75	.38	1.50	11.12	8.53	2.53	4.25	5.00
MM	361	52	41.28	95	10		282	217	64	108	127

UNITS	ES MIN	EV	SQ KEY
IN	2.91	1.00	.375
MM	74	25	9.53

FRAME	UNITS	2F ±.03
254T	IN	8.25
	MM	210
256T	IN	10.00
	MM	254

1. ALL ROUGH CASTING DIMENSIONS MAY VARY BY .25" DUE TO CASTING AND/OR FABRICATION VARIATIONS.
2. LARGEST MOTOR WIDTH.
3. TOLERANCES SHOWN ARE IN INCHES ONLY.

4. STANDARD ASSEMBLY POSITION F-1 IS SHOWN F-2 IS PROVIDED WHEN SPECIFIED. CONDUIT OPENINGS MAY BE LOCATED IN STEPS OF 90 DEGREES REGARDLESS OF LOCATION. STANDARD AS SHOWN WITH CONDUIT OPENING DOWN.
5. THIS UNIT MAY HAVE HORIZONTAL LIFTING, VERTICAL LIFTING OR BOTH.

07-2837/D

Nidec Motor Corporation
St. Louis, Missouri

INFORMATION DISCLOSED ON THIS DOCUMENT IS CONSIDERED PROPRIETARY AND SHALL NOT BE REPRODUCED OR DISCLOSED WITHOUT WRITTEN CONSENT OF NIDEC MOTOR CORPORATION



ISSUED BY
G. MARTINEZ
APPROVED BY
K. VALADEZ

IHP_DP_NMCA (MAR-2011) SOLIDEDGE