

EFFECTIVE:  
07-JUL-16

SUPERSEDES:  
25-APR-11

**DIMENSION PRINT**  
WEATHER PROTECTED TYPE I  
FRAME: 250TP, TPA, TPH  
BASIC TYPE: AU

PRINT:  
09-2289

SHEET:  
1 OF 1

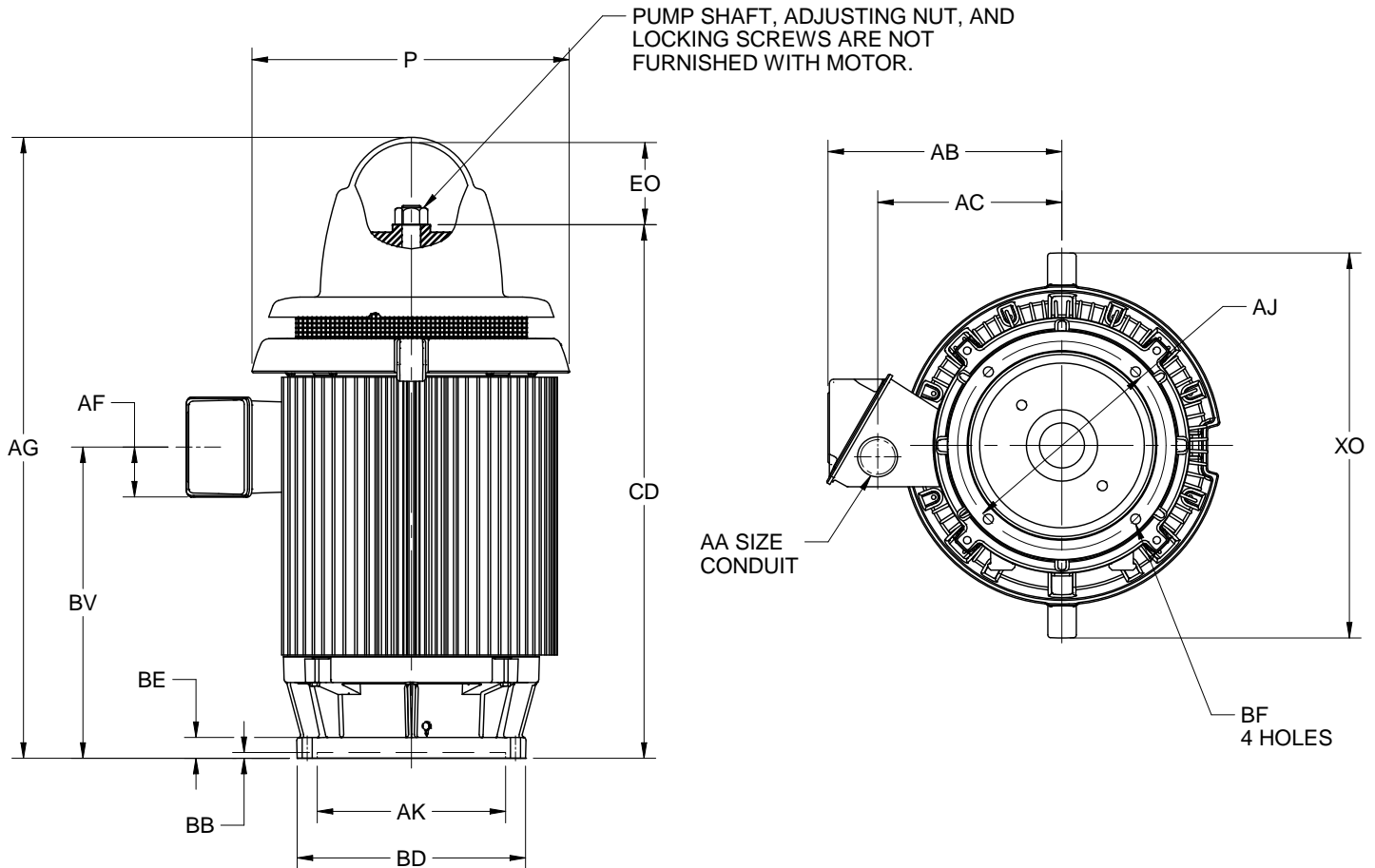

ALL DIMENSIONS ARE IN INCHES AND MILLIMETERS

UNITS	P <sup>2</sup>	AA	AB	AC	AF	AG <sup>5</sup>	BB MIN	BE	BV	CD <sup>5</sup>	EO	XO
IN	14.00	1.25	10.25	7.88	2.03	26.75	.25	.94	11.50	23.38	3.25	16.88
MM	356		260	200	52	679	6	24	292	594	83	429

FRAME	UNITS	AJ	AK	BD MAX	BF
254, 256TP	IN	9.125	8.250	10.00	.44
	MM	231.78	209.55	254	11
254, 256TPA	IN	14.750	13.500	16.50	.69
	MM	374.65	342.90	419	18
254, 256TPH	IN	9.125	8.250	12.00	.44
	MM	231.78	209.55	305	11

1. ALL ROUGH DIMENSIONS MAY VARY BY .25" DUE TO CASTING AND/OR FABRICATION VARIATIONS.
2. LARGEST MOTOR WIDTH.
3. TOLERANCES SHOWN ARE IN INCHES ONLY.

4. CONDUIT OPENINGS MAY BE LOCATED IN STEPS OF 180 DEGREES REGARDLESS OF LOCATION. STANDARD AS SHOWN.
5. DIMENSIONS SHOWN ARE FOR ALL RATINGS EXCEPT 20 HP, 4 POLE, TYPE AUE AND AUJ. FOR THIS RATING THE DIMENSIONS ARE: AG=28.13 (715 MM)  
CD=24.75 (629 MM)

09-2289/E

**Nidec Motor Corporation**  
St. Louis, Missouri

INFORMATION DISCLOSED ON THIS DOCUMENT IS CONSIDERED PROPRIETARY AND SHALL NOT BE REPRODUCED OR DISCLOSED WITHOUT WRITTEN CONSENT OF NIDEC MOTOR CORPORATION



ISSUED BY  
**R. MARTINEZ**  
APPROVED BY  
**R. ALVAREZ**

IHP\_DP\_NMCA (MAR-2011) SOLIDEDGE