

EFFECTIVE:
12-JAN-16

DIMENSION PRINT

PRINT:
07-1942

SUPERSEDES:
26-JUL-13

FRAME: 320T
BASIC TYPE: CT

SHEET:
1 OF 1

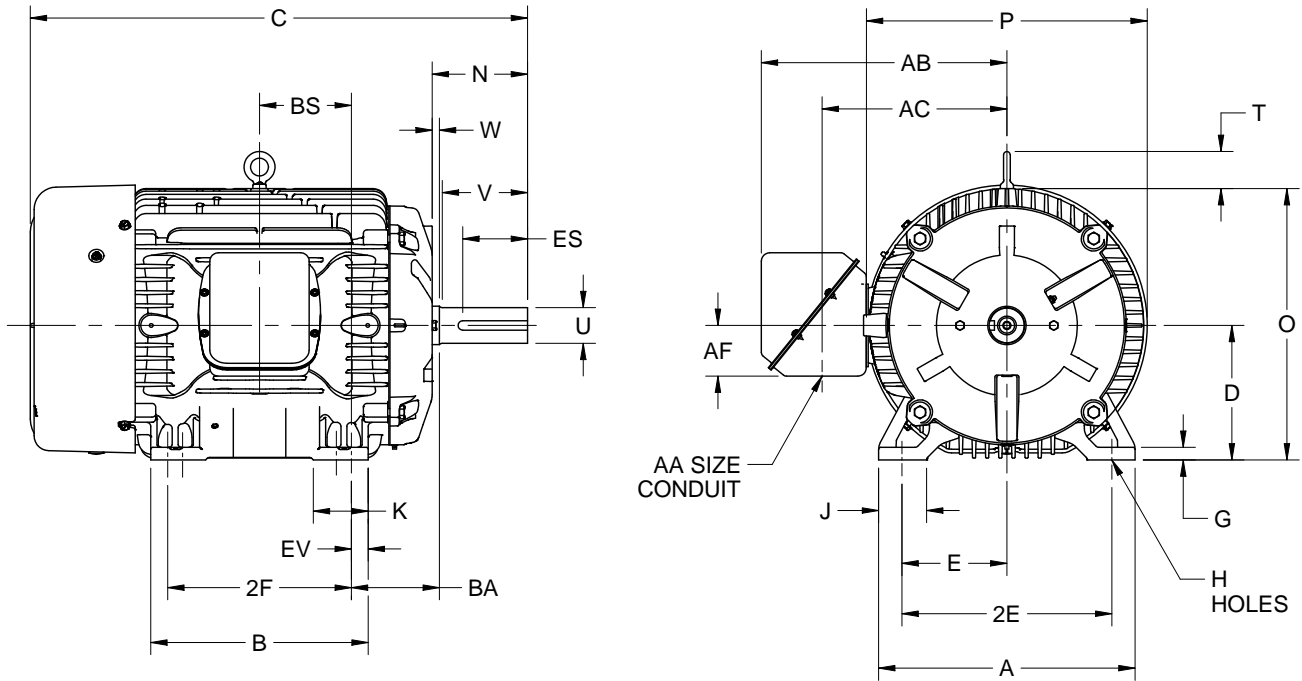

	A	B	C	D -.06	E	2E ±.03	G	H +.05	J
IN	15.75	13.75	30.56	8.00	6.25	12.50	.75	.66	3.19
MM	400	349	776	203	159	318	19	17	81

	K	N	N-W	O	P ²	T	U -.001	V MIN	W
IN	3.25	5.75	5.25	16.25	16.88	2.50	2.125	5.00	.50
MM	83	146	133	413	429	64	53.98	127	13

	AA	AB	AC	AF	BA ±.09	BS	ES MIN	EV	SQ KEY
IN	3.00	15.50	11.38	3.38	5.25	6.00	3.91	.88	.500
MM	3.00	394	289	86	133	152	99	22	12.70

	FRAME	2F ±.03
IN	324T	10.50
MM		267
IN	326T	12.00
MM		305

1. DIMENSIONS MAY VARY .25" DUE TO CASTING AND/OR FABRICATION VARIATIONS.
2. LARGEST MOTOR WIDTH
3. TOLERANCES ARE SHOWN IN INCHES.
4. CONDUIT BOX MAY BE LOCATED ON EITHER SIDE OF MOTOR. CONDUIT OPENINGS MAY BE LOCATED IN STEPS OF 90 DEGREES REGARDLESS OF LOCATION. STANDARD AS SHOWN WITH CONDUIT OPENING DOWN.

07-1942/F

Nidec Motor Corporation
St. Louis, Missouri

INFORMATION DISCLOSED ON THIS DOCUMENT IS CONSIDERED PROPRIETARY AND SHALL NOT BE REPRODUCED OR DISCLOSED WITHOUT WRITTEN CONSENT OF NIDEC MOTOR CORPORATION



ISSUED BY
R. KING
APPROVED BY
J. O'BRIEN

IHP_DP_NMCA (MAR-2011) SOLIDEDGE