

EFFECTIVE:
18-DEC-14

DIMENSION PRINT

ODP-COUPLE PUMP MOTORS (VERTICAL MOUNTING)

PRINT:
07-3138-02

SUPERSEDES:
NEW

FRAME: 143JM THRU 145JP
BASIC TYPE: DF-1, DF-4

SHEET:
1 OF 1

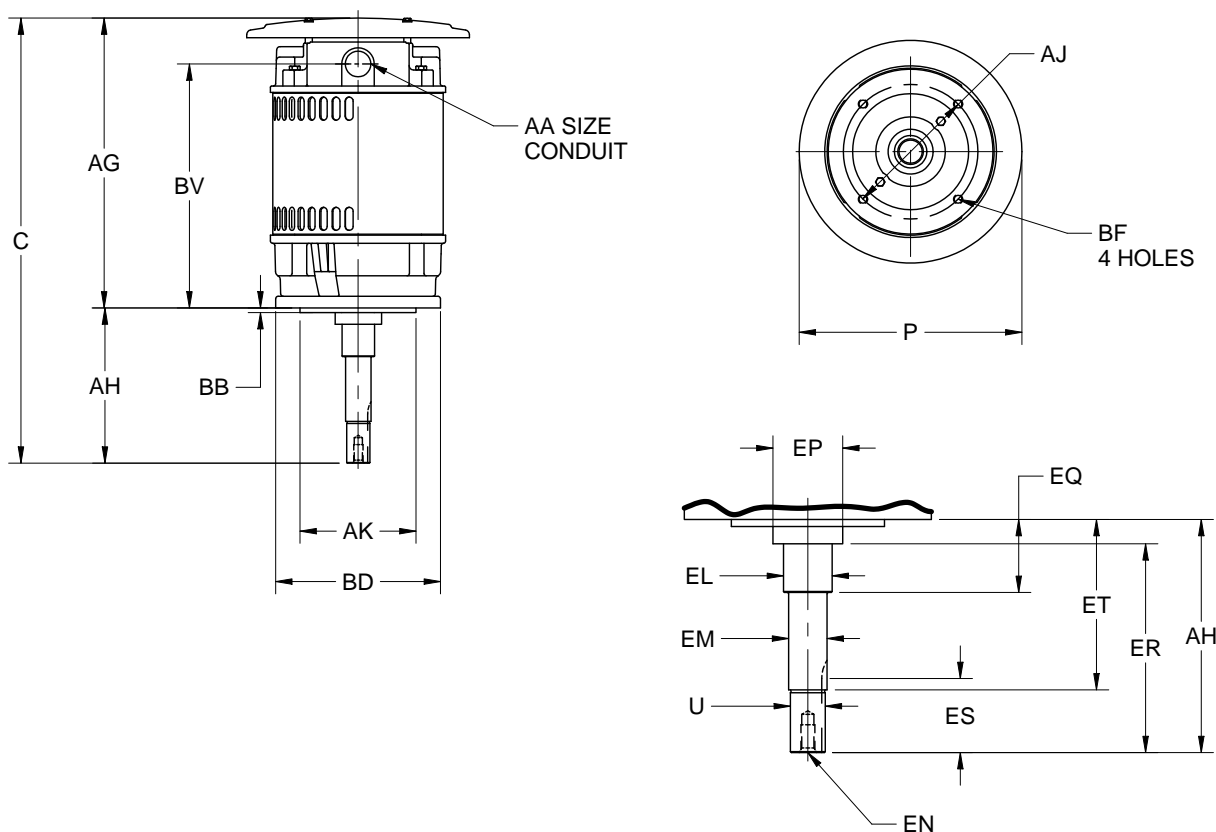

ALL DIMENSIONS ARE IN INCHES AND MILLIMETERS

UNITS	P ³	U -.0005	AA	AG	AJ	AK -.003	BB -.031	BD MAX	BF ²	BV	EL -.002	EM -.0005
IN	8.63	.8745	3/4 NPT	11.36	5.875	4.500	.156	6.63	3/8-16 X .56	9.66	1.156	1.0000
MM	219	22.212		289	149.23	114.30	3.96	168		245	29.36	25.400

UNITS	EN ²	EP MIN	ES MIN	SQ KEY
IN	3/8-16 X .75	1.16	1.65	.188
MM		29	42	4.78

FRAME	UNITS	C	AH ±.031	EQ ±.015	ER MIN	ET ±.015
140JM	IN	15.61	4.250	.625	4.25	2.875
	MM	396	107.95	15.88	108	73.03
140JP	IN	18.67	7.313	1.563	7.31	5.938
	MM	474	185.75	39.70	186	150.83

1. ALL ROUGH CASTING DIMENSIONS MAY VARY BY .25" DUE TO CASTING AND/OR FABRICATION VARIATIONS.
2. TAP SIZE AND BOLT PENETRATION ALLOWANCE.
3. LARGEST MOTOR WIDTH.
4. ALL TAPPED HOLES ARE UNIFIED NATIONAL COARSE, RIGHT HAND THREAD.
5. TOLERANCES ARE IN INCHES ONLY.
6. FRAME REFERENCE 7.750/143/145.

TOLERANCES	
FACE RUNOUT	.004 T.I.R.
PERMISSIBLE ECCENTRICITY OF MOUNTING RABBET	.004 T.I.R.
PERMISSIBLE SHAFT RUNOUT	.002 T.I.R.

Nidec Motor Corporation
St. Louis, Missouri

INFORMATION DISCLOSED ON THIS DOCUMENT
IS CONSIDERED PROPRIETARY AND SHALL NOT BE
REPRODUCED OR DISCLOSED WITHOUT WRITTEN
CONSENT OF NIDEC MOTOR CORPORATION



ISSUED BY
S. MONTALVO
APPROVED BY
J. AGUILAR