

VIEW A-A

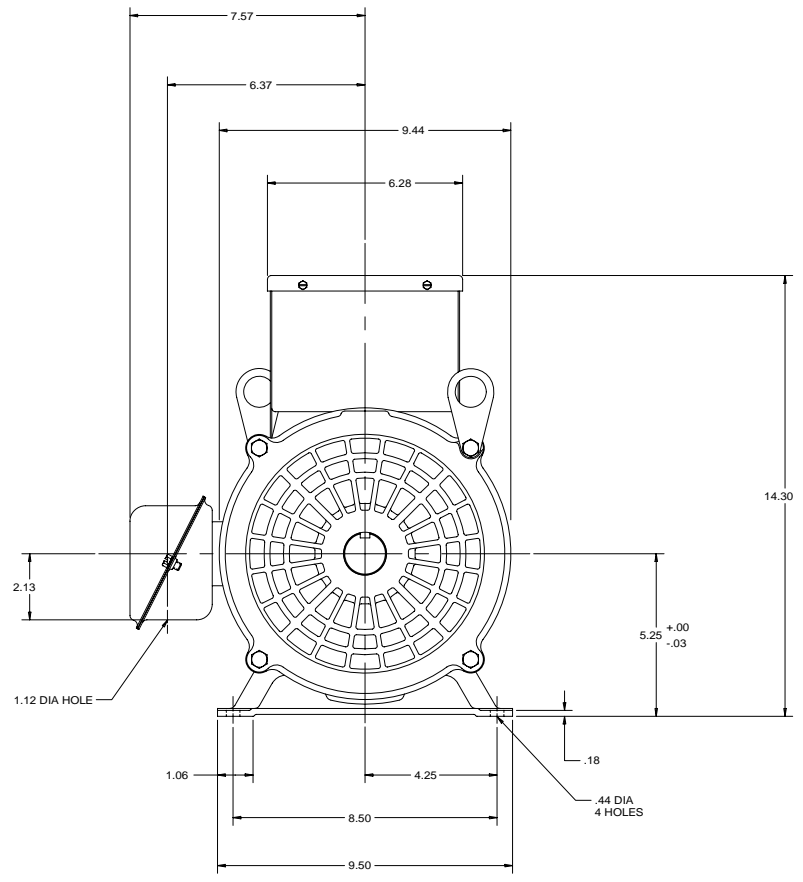

FRAME	TYPE	HP	RPM	PH	HZ	SF	VOLTS	AMPS
213T-52	DM	7.5	3480	1	60	1.15	230	30.3

REVISION DESCRIPTION FOR: A1000-50 UPDATED TO NIDEC FORMAT.		SCALE: NONE	UNITS: IN	TITLE: DRAWING, DIMENSION	NIDEC MOTOR CORPORATION
TOLERANCES ON DIMENSIONS (UNLESS OTHERWISE SPECIFIED): INCHES: .XX = ± .03 .XXX = ± .015		MATERIAL: ---		ISSUED BY: R. KING	
MUST BE COMPLIANT TO RoHS DIRECTIVE EU 2002/95/EC AND REGULATION EC 1907/2006/REACH AS AMENDED.		APPROVED BY: J. HAGENE		REVISION DATE: 13-OCT-11	SHEET NUMBER: A 1 OF 1
ANGLES X° = ±1°		CODE: DP	DWG NO.: 0476473	DRW SIZE: D	

NIDEC CONFIDENTIAL  
NIDEC MOTOR CORPORATION 13-04-11