

VAR	MODEL	CUSTOMER	CAT. NO.	A	B	C	D	HP	VOLTS	SF	AMPS	HZ	RPM	CONN VOLTS	PROT.	DESCRIPTION / REMARKS
001	T55CPR-1521	USEM	D12CP2P	9.441	-----	-----	-----	1/2	115/230	1.25	5.0/2.6	60	1725	-----	NONE	N56, ODP
002	T55KXCPW-1526	USEM	D12CPM2P	9.441	-----	-----	-----	1/2	115/230	1.25	5.0/2.6	60	1725	-----	MANUAL	N56, ODP

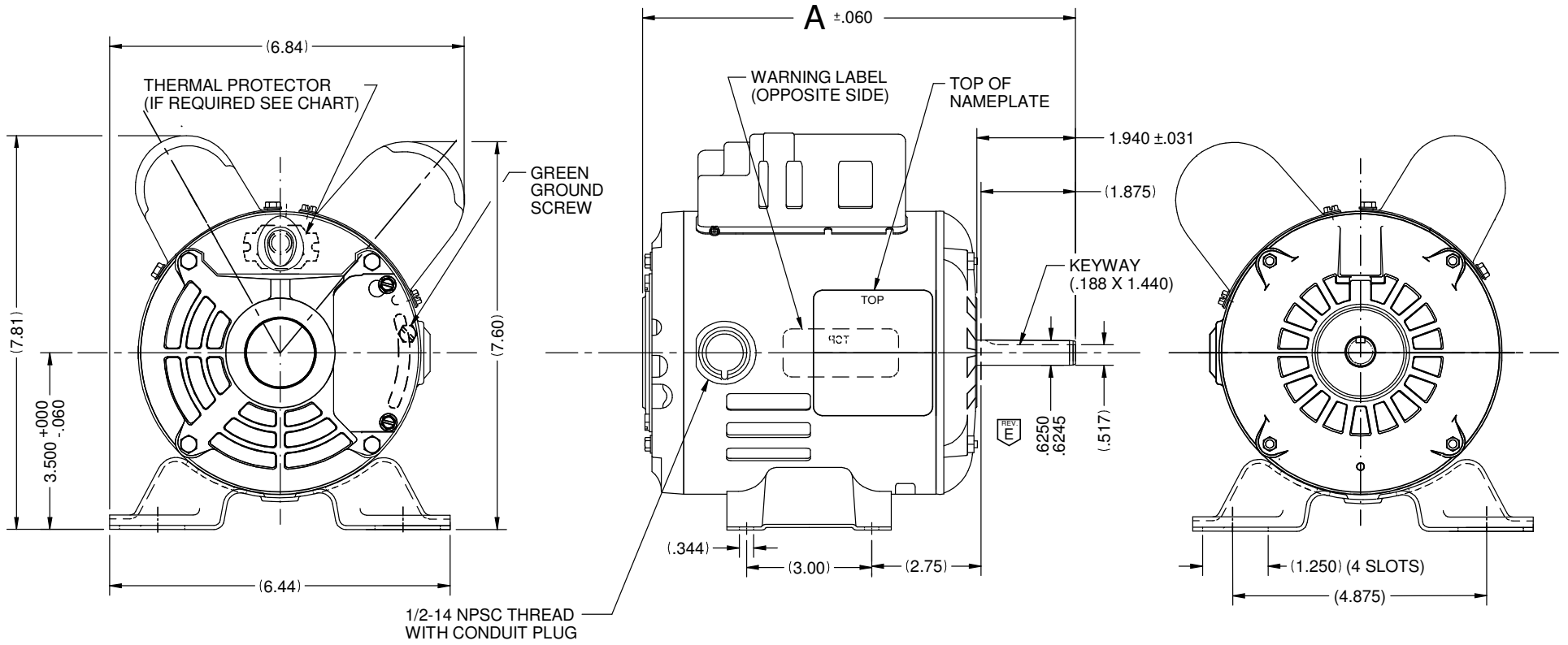

MOTOR IS CCW ROTATION LEAD END, TO REVERSE ROTATION INTERCHANGE BLUE WITH WHITE AND ORANGE WITH YELLOW

REFER TO S.E.I.M. 24-1

NIDEC MOTOR CORPORATION 30-Oct-18

REVISION RECORD FOR:	ECO E32630
NAMEPLATE VIEW WAS UPDATED ON DRAWING	

TOLERANCES ON DIMENSIONS (UNLESS OTHERWISE SPECIFIED)

INCHES	mm
.XX = ± .010	
.XXX = ± .005	

ANGLES X° = ±1°

NIDEC MOTOR CORPORATION

INFORMATION DISCLOSED ON THIS DOCUMENT IS CONSIDERED PROPRIETARY AND SHALL NOT BE REPRODUCED OR DISCLOSED WITHOUT WRITTEN CONSENT OF NIDEC MOTOR CORPORATION

REVISION DATE: 30-OCT-18

ISSUED BY: G. TREVIÑO ENGINEER APPROVED: M. SCHUETTE

TITLE		CODE	ITEM NO.	REV	SHEET NUMBER	DWG SIZE
CUSTOMER DETAIL DRAWING		V02	803668	E	1 OF 4	B