

EFFECTIVE:  
20-OCT-17

# DIMENSION PRINT

## TEFC - WITH STEARNS BRAKE

PRINT:  
07-3289

SUPERSEDES:  
05-AUG-16

FRAME: 184T  
BASIC TYPE: UT

SHEET:  
1 OF 1

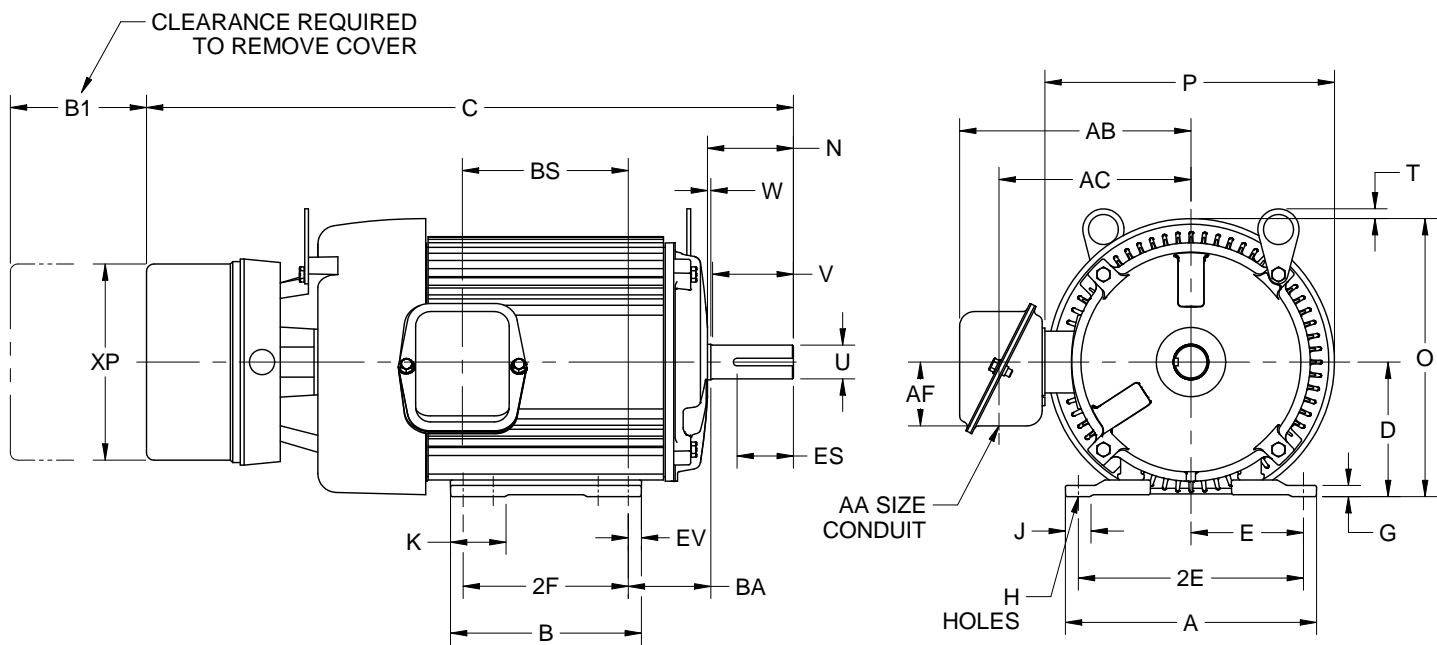

ALL DIMENSIONS ARE IN INCHES AND MILLIMETERS

UNITS	A	B	C	D -.06	E	2E ±.03	2F ±.03	G	H +.05	J	K	N
IN	8.38	6.38	22.31	4.50	3.75	7.50	7.00	.38	.41	.88	1.88	2.88
MM	213	162	567	143	95	191	178	10	10	22	48	73

UNITS	O	P <sup>2</sup>	T	U -.0005	V MIN	W	AA	AB	AC	AF	BA	BS
IN	9.28	9.66	.34	1.1250	2.56	.13	.75	7.72	6.41	2.13	3.75	6.28
MM	236	245	9	28.575	65	3		196	163	54	95	160

UNITS	B1	ES MIN	EV	XP	SQ KEY
IN	2.94	1.78	.44	6.54	.250
MM	75	45	11	166	6.35

NOTE:  
THIS PRINT IS GOOD FOR MOTORS WITH STEARNS  
BRAKE 56,3XXX SERIES, (OPEN) ENCLOSURE  
RANGING FROM 1.5 THRU 25 LB. FT.

1. DIMENSIONS MAY VARY BY .25" DUE TO CASTING AND/OR FABRICATION VARIATIONS.
2. LARGEST MOTOR WIDTH.
3. TOLERANCES SHOWN ARE IN INCHES ONLY.
4. CONDUIT BOX MAY BE LOCATED ON EITHER SIDE OF MOTOR. CONDUIT OPENING MAY BE LOCATED IN STEPS OF 90 DEGREES REGARDLESS OF LOCATION. STANDARD AS SHOWN WITH CONDUIT OPENING DOWN.
5. REFERENCE FRAME: 9.000"/184

07-2670/B

**Nidec Motor Corporation**  
St. Louis, Missouri

INFORMATION DISCLOSED ON THIS DOCUMENT  
IS CONSIDERED PROPRIETARY AND SHALL NOT BE  
REPRODUCED OR DISCLOSED WITHOUT WRITTEN  
CONSENT OF NIDEC MOTOR CORPORATION



ISSUED BY <b>D. CISNEROS</b>
APPROVED BY <b>R. ALVAREZ</b>

IHP\_DP\_NMCA (MAR-2011) SOLIDEDGE