

EFFECTIVE:
27-DEC-12

HORIZONTAL MOTORS

TEFC - WITH STEARNS BRAKE

PRINT:
07-2667

SUPERSEDES:
30-MAY-11

FRAME: 140T
BASIC TYPE: UT

SHEET:
1 OF 1

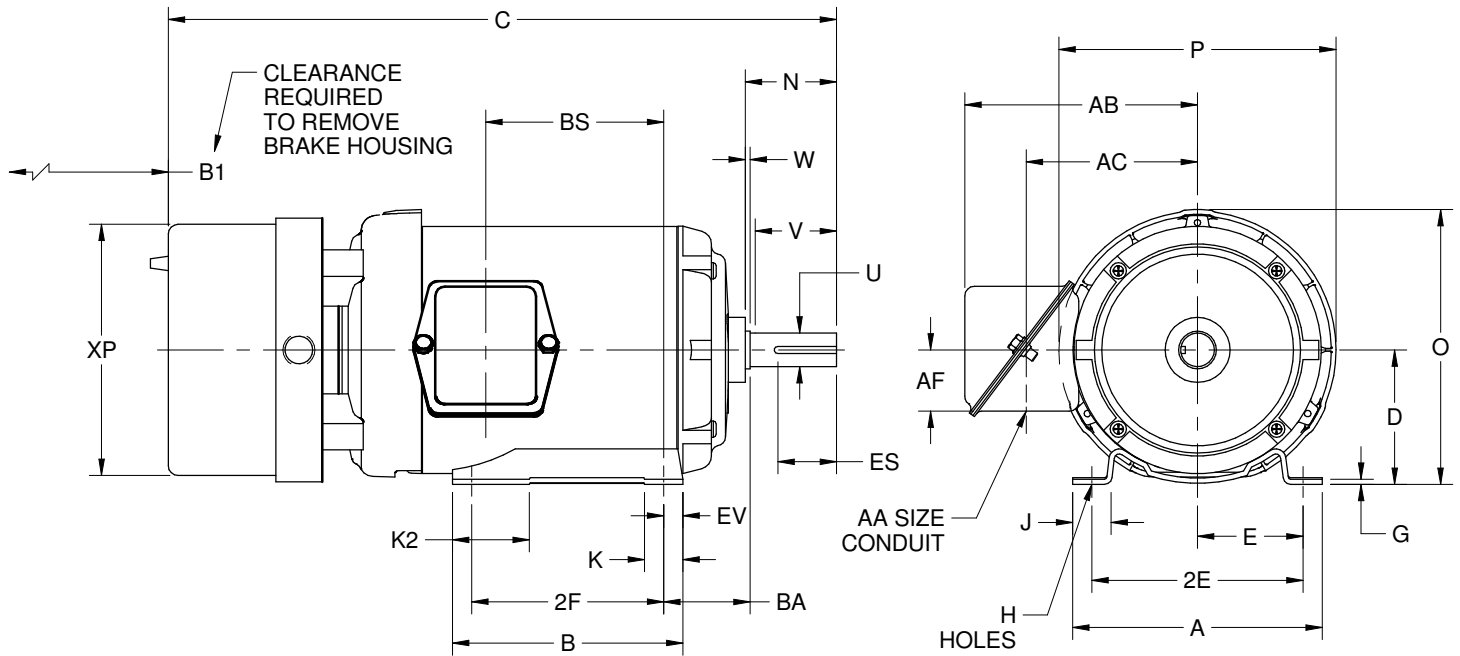

DIMENSIONS ARE IN INCHES AND MILLIMETERS

	A	B	D -.06	E	2E ±.03	G	H +.05	J	K
IN	6.50	6.00	3.50	2.75	5.50	.13	.34	1.00	1.00
MM	165	152	89	70	140	3	9	25	25

	K2	N	O	P ²	U -.0005	V MIN	W	AA	AB
IN	2.00	2.38	7.16	7.31	.8750	2.00	.13	.75	6.09
MM	51	60	182	186	22.225	51	3		155

	AC	AF	BA	B1	ES MIN	EV	XP	SQ KEY
IN	4.50	1.59	2.25	2.94	1.41	.50	6.54	.188
MM	114	40	57	75	36	13	1.66	4.78

	FRAME	C	2F ±.03	BS
IN	143T	18.88	4.00	4.64
MM	(6.75")	480	102	118
IN	145T	18.88	5.00	4.64
MM	(6.75")	480	127	118
IN	145T	19.88	5.00	5.64
MM	(7.75")	505	127	143

NOTE:
THIS PRINT IS GOOD FOR MOTORS WITH STEARNS BRAKE 56.3XXX SERIES, (OPEN) ENCLOSURE RANGING FROM 1.5 THRU 15 LB. FT.

1. DIMENSIONS MAY VARY .25" DUE TO CASTING AND/OR FABRICATION VARIATIONS.
2. LARGEST MOTOR WIDTH.
3. STANDARD ASSEMBLY POSITION F-1 IS SHOWN. F-2 IS PROVIDED WHEN SPECIFIED. CONDUIT OPENING MAY BE LOCATED IN STEPS OF 180°. STANDARD AS SHOWN WITH CONDUIT OPENING DOWN.
4. TOLERANCES ARE IN INCHES.

07-2667/B

Nidec Motor Corporation
St. Louis, Missouri

INFORMATION DISCLOSED ON THIS DOCUMENT IS CONSIDERED PROPRIETARY AND SHALL NOT BE REPRODUCED OR DISCLOSED WITHOUT WRITTEN CONSENT OF NIDEC MOTOR CORPORATION



ISSUED BY
K. FRIEDMAN
APPROVED BY
J. O'BRIEN

IHP_DP_NMCA (MAR-2011) SOLIDEDGE