

EFFECTIVE:
28-OCT-16

SUPERSEDES:
NEW

DIMENSION PRINT
TEBC (AXIAL) W/ OVERSIZED O/B
FRAME: 360T, TS
BASIC TYPE: TCBI, TCBI

PRINT:
07-3274-01

SHEET:
1 OF 1

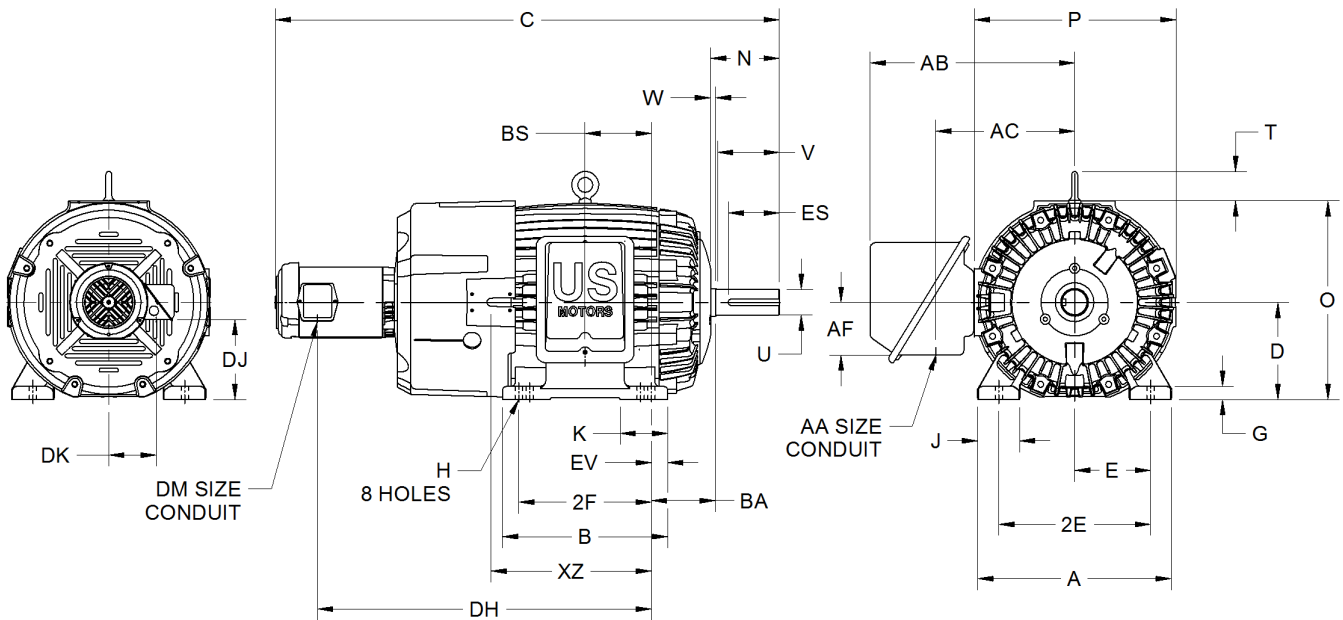

ALL DIMENSIONS ARE IN INCHES AND MILLIMETERS

UNITS	A	B	D -.06	E	2E ±.03	G	H +.05	J	K	O	P ²
IN	17.94	15.25	9.00	7.00	14.00	1.22	.66	3.94	4.38	18.31	18.13
MM	456	387	229	178	356	31	17	100	111	465	460

UNITS	T	W	AA	AB	AC	AF	BA	BS	DH	DJ	DK
IN	2.72	.44	3 NPT	18.88	12.81	4.88	5.88	6.13	30.81	7.38	4.50
MM	69	11		480	325	124	149	156	783	187	114

UNITS	DM	EV	XZ
IN	.75	1.50	14.81
MM		38	376

FRAME	UNITS	C	N	U -.001	V MIN	ES MIN	SQ KEY
364, 365T	IN	46.50	6.31	2.375	5.62	4.28	.625
	MM	1181	160	60.33	143	109	15.88
364, 365TS	IN	44.38	4.19	1.875	3.50	2.03	.500
	MM	1127	106	47.63	89	52	12.70

FRAME	UNITS	2F ±.03
364T, TS	IN	11.25
	MM	286
365T, TS	IN	12.25
	MM	311

1. DIMENSIONS MAY VARY .25" DUE TO CASTING AND/OR FABRICATION VARIATIONS
2. LARGEST MOTOR WIDTH

3. STANDARD ASSEMBLY POSITION F-1 IS SHOWN. F-2 IS PROVIDED WHEN SPECIFIED. CONDUIT OPENINGS MAY BE LOCATED IN STEPS OF 90° REGARDLESS OF THE LOCATION
4. TOLERANCES ARE SHOWN IN INCHES ONLY

07-3274/-

Nidec Motor Corporation
St. Louis, Missouri

INFORMATION DISCLOSED ON THIS DOCUMENT IS CONSIDERED PROPRIETARY AND SHALL NOT BE REPRODUCED OR DISCLOSED WITHOUT WRITTEN CONSENT OF NIDEC MOTOR CORPORATION



ISSUED BY
R. MARTINEZ
APPROVED BY
T. PALLETT

IHP_DP_NMCA (MAR-2011) SOLIDEDGE