

EFFECTIVE:  
**19-OCT-16**

SUPERSEDES:  
**NEW**

**DIMENSION PRINT**  
TEBC (AXIAL) W/ OVERSIZED O/B  
FRAME: 320T,TS  
BASIC TYPE: TCB,TCBI

PRINT:  
**07-3271-01**

SHEET:  
**1 OF 1**

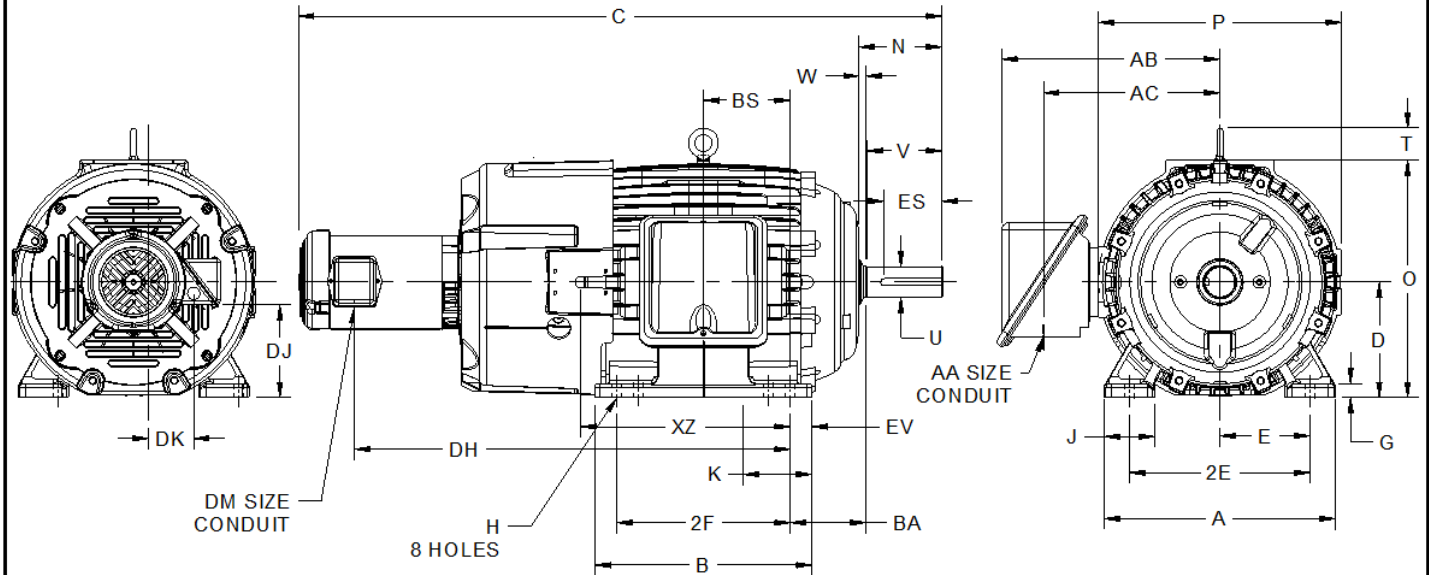

ALL DIMENSIONS ARE IN INCHES AND MILLIMETERS

UNITS	A	B	D -.06	E	2E ±.03	G	H +.05	J	K	O	P <sup>2</sup>
IN	16.00	15.00	8.00	6.25	12.50	1.00	.66	3.50	4.75	16.38	16.38
MM	406	381	203	159	318	25	17	89	121	416	416

UNITS	T	W	AA	AB	AC	AF	BA	BS	DH	DJ	DK
IN	2.25	.47	2 NPT	15.44	12.19	3.81	5.25	6.00	30.13	6.38	4.50
MM	57	12		392	309	97	133	152	765	162	114

UNITS	DM	EV	SQ KEY	XZ
IN	.75	1.50	.500	14.50
MM		38	12.70	368

FRAME	UNITS	C	N	U -.001	V MIN	ES MIN
324, 326T	IN	44.56	5.75	2.125	5.00	3.91
	MM	1132	146	53.98	127	99
324, 326TS	IN	43.06	4.25	1.875	3.50	2.03
	MM	1094	108	47.63	89	52

FRAME	UNITS	2F ±.03
324T, TS	IN	10.50
	MM	267
326T, TS	IN	12.00
	MM	305

1. DIMENSIONS MAY VARY .25" DUE TO CASTING AND/OR FABRICATION VARIATIONS
2. LARGEST MOTOR WIDTH
3. STANDARD ASSEMBLY POSITION F-1 IS SHOWN. F-2 IS PROVIDED WHEN SPECIFIED. CONDUIT OPENINGS MAY BE LOCATED IN STEPS OF 90° REGARDLESS OF THE LOCATION
4. TOLERANCES ARE SHOWN IN INCHES ONLY

**Nidec Motor Corporation**  
St. Louis, Missouri

INFORMATION DISCLOSED ON THIS DOCUMENT IS CONSIDERED PROPRIETARY AND SHALL NOT BE REPRODUCED OR DISCLOSED WITHOUT WRITTEN CONSENT OF NIDEC MOTOR CORPORATION



ISSUED BY  
**M. YRISSON**  
APPROVED BY  
**T. PALLETT**

IHP\_DP\_NMCA (MAR-2011) SOLIDEDGE