

EFFECTIVE:
02-NOV-16

SUPERSEDES:
NEW

DIMENSION PRINT
TEBC (AXIAL)
FRAME: 250TC
BASIC TYPE: TCB, TCBI

PRINT:
07-3265

SHEET:
1 OF 1

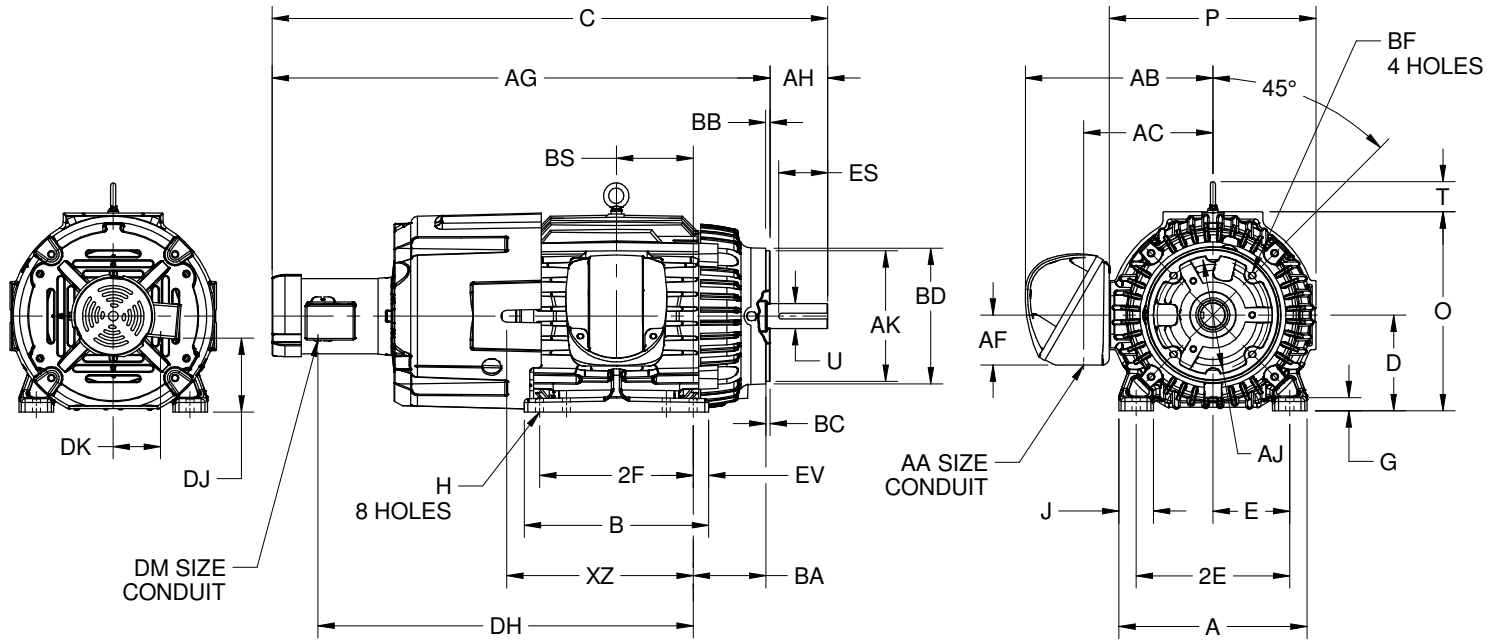

ALL DIMENSIONS ARE IN INCHES AND MILLIMETERS

UNITS	A	B	C	D -.06	E	2E ±.03	G	H +.05	J	O	P ²	U -.001
IN	12.26	12.00	36.19	6.25	5.00	10.00	.88	.53	2.25	12.94	13.25	1.625
MM	311	305	919	159	127	254	22	13	57	329	337	41.28

UNITS	T	AA	AB	AC	AF	AG	AH	AJ	AK -.003	BA	BB MIN	BC
IN	2.03	1.50 NPT	12.25	8.44	2.63	32.38	3.75	7.250	8.500	4.75	.25	.25
MM	52		311	214	67	822	95	184.15	215.90	121	6	6

UNITS	BD MAX	BF ^{3,4}	BS	DH	DJ	DK	DM	ES MIN	EV	SQ KEY	XZ
IN	10.00	1/2-13 X .75	5.00	24.44	4.81	3.09	.50	2.91	1.00	.375	12.13
MM	254		127	621	122	78		74	25	9.53	308

FRAME	UNITS	2F ±.03
254TC	IN	8.25
	MM	210
256TC	IN	10.00
	MM	254

TOLERANCES	
FACE RUNOUT	.004 T.I.R.
PERMISSIBLE ECCENTRICITY OF MOUNTING RABBET	.004 T.I.R.
PERMISSIBLE SHAFT RUNOUT	.002 T.I.R.

1. DIMENSIONS MAY VARY .25" DUE TO CASTING AND/OR FABRICATION VARIATIONS
2. LARGEST MOTOR WIDTH
3. ALL TAP HOLES ARE UNIFIED NATIONAL COARSE, RIGHT HAND THREAD
4. TAP SIZE AND BOLT PENETRATION ALLOWANCE
5. STANDARD ASSEMBLY POSITION F-1 IS SHOWN. F-2 IS PROVIDED WHEN SPECIFIED. CONDUIT OPENINGS MAY BE LOCATED IN STEPS OF 90° REGARDLESS OF THE LOCATION
6. TOLERANCES ARE SHOWN IN INCHES ONLY

07-3265/-

Nidec Motor Corporation
St. Louis, Missouri

INFORMATION DISCLOSED ON THIS DOCUMENT IS CONSIDERED PROPRIETARY AND SHALL NOT BE REPRODUCED OR DISCLOSED WITHOUT WRITTEN CONSENT OF NIDEC MOTOR CORPORATION



ISSUED BY
O. RODRIGUEZ
APPROVED BY
T. PALLETT

IHP_DP_NMCA (MAR-2011) SOLIDEDGE