

EFFECTIVE:
14-FEB-17

SUPERSEDES:
NEW

DIMENSION PRINT
TEBC (AXIAL) W/ OVERSIZED O/B
FRAME: 400T
BASIC TYPE: TCB, TCBI

PRINT:
07-3277-01

SHEET:
1 OF 1

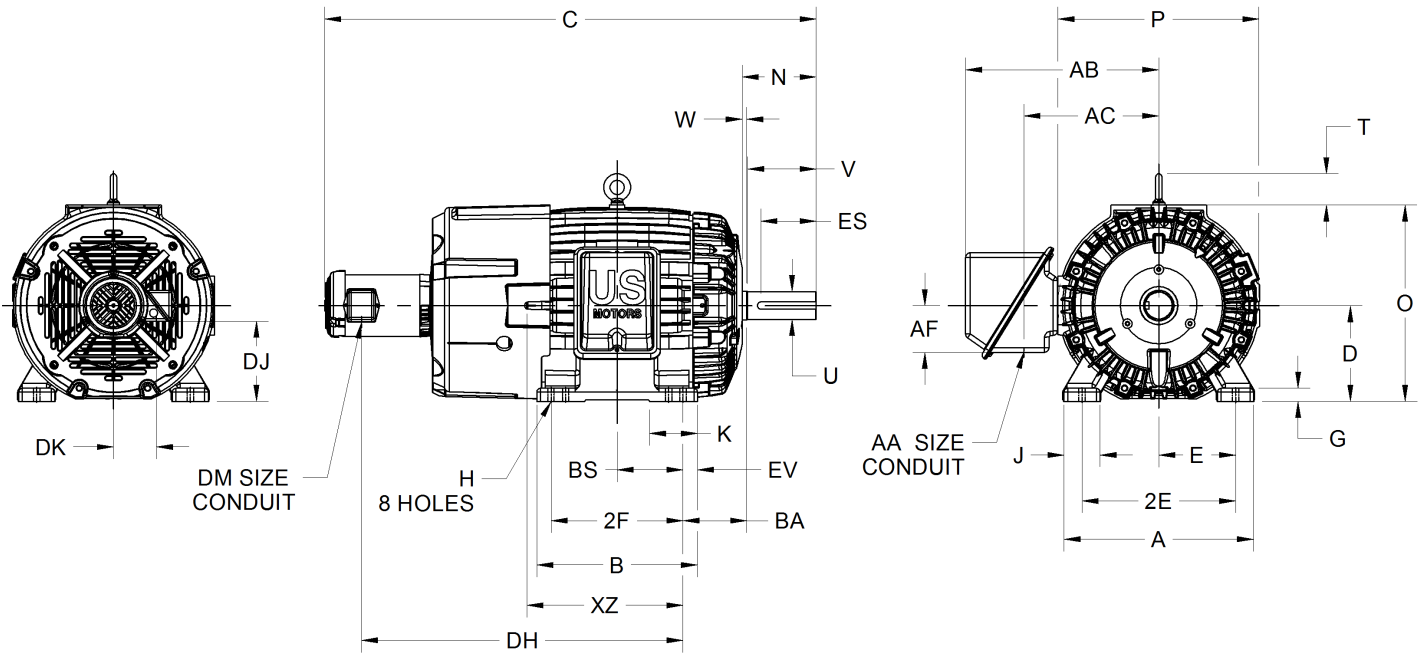

ALL DIMENSIONS ARE IN INCHES AND MILLIMETERS

UNITS	A	B	C	D -.06	E	2E ±.03	G	H +.05	J	K	N
IN	19.75	16.75	51.25	10.00	8.00	16.00	1.38	.81	3.75	5.00	7.63
MM	502	425	1302	254	203	406	35	21	95	127	194

UNITS	O	P ²	T	U -.001	V MIN	W	AA	AB	AC	AF	BA
IN	20.47	20.75	3.22	2.875	7.00	.38	3.00 NPT	20.13	14.06	4.88	6.63
MM	520	527	82	73.03	178	10		511	357	124	168

UNITS	BS	DH	DJ	DK	DM	ES MIN	EV	XZ	SQ KEY
IN	6.88	33.50	8.38	4.50	.75	5.66	1.50	16.13	.750
MM	175	851	213	114		144	38	410	19.05

FRAME	UNITS	2F ±.03
404T	IN	12.25
	MM	311
405T	IN	13.75
	MM	349

1. ALL ROUGH CASTING DIMENSIONS MAY VARY BY .25" DUE TO CASTING AND/OR FABRICATION VARIATIONS.
2. LARGEST MOTOR WIDTH.
3. TOLERANCES SHOWN ARE IN INCHES ONLY.

4. STANDARD ASSEMBLY POSITION F-1 IS SHOWN F-2 IS PROVIDED WHEN SPECIFIED. CONDUIT OPENINGS MAY BE LOCATED IN STEPS OF 90 DEGREES REGARDLESS OF LOCATION. STANDARD AS SHOWN WITH CONDUIT OPENING DOWN.

07-32771-

Nidec Motor Corporation
St. Louis, Missouri

INFORMATION DISCLOSED ON THIS DOCUMENT IS CONSIDERED PROPRIETARY AND SHALL NOT BE REPRODUCED OR DISCLOSED WITHOUT WRITTEN CONSENT OF NIDEC MOTOR CORPORATION



ISSUED BY
F. CRUZ
APPROVED BY
T. PALLETT

IHP_DP_NMCA (MAR-2011) SOLIDEDGE