

MODEL	REF	CUSTOMER	HP	VOLTS	AMPS	HZ	RPM	ROTATION	CUSTOMER PT. NO.	DESCRIPTION / REMARKS
K55HXSEN-651		STANDARD	1/3	208-230	2.7	60	825	REVERSIBLE	7040	K55 HUB OR STUD MTD. BALL BRG., OPEN

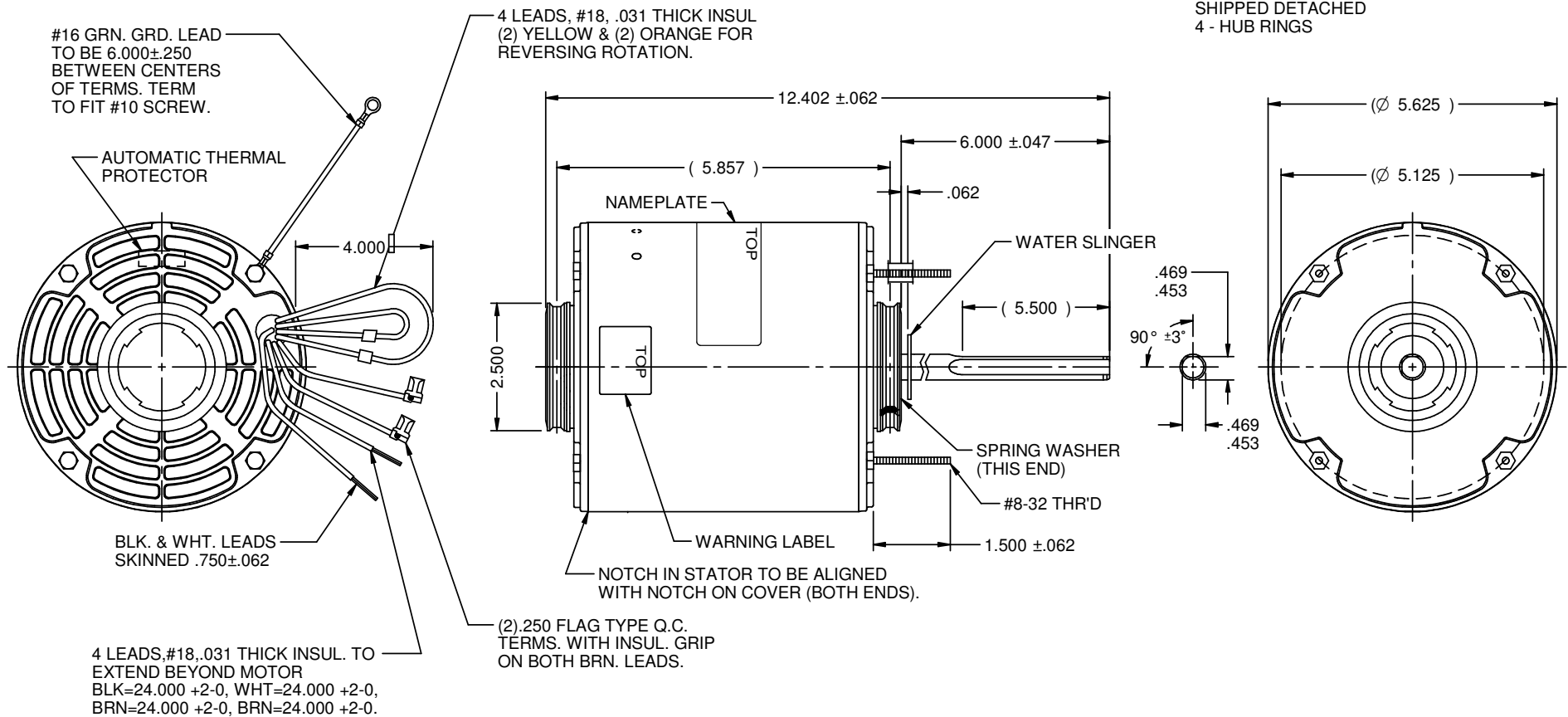

NIDEC MOTOR CORPORATION 14-Nov-18

REFER TO S.E.I.M. 24-1

NEW DRAWING.	REVISION RECORD FOR:	ECO: E32643
ISSUED BY:	ENGINEER APPROVED:	
G. ISASSI	Z. TREVIÑO	

DIMENSIONS ARE FOR REFERENCE ONLY

UNLESS TOLERANCE IS SPECIFIED

NIDEC MOTOR CORPORATION

INFORMATION DISCLOSED ON THIS DOCUMENT IS CONSIDERED PROPRIETARY AND SHALL NOT BE REPRODUCED OR DISCLOSED WITHOUT WRITTEN CONSENT OF NIDEC MOTOR CORPORATION

REVISION DATE:
14-NOV-18

TITLE	CODE	ITEM NO.	REV	SHEET NUMBER	DWG SIZE
CUSTOMER DETAIL DRAWING	V02	823541	-	1 OF 3	B