

MODEL	REF	CUSTOMER	HP	VOLTS	AMPS	HZ	RPM	ROTATION	CAT. NO.	DESCRIPTION / REMARKS
K48ZZTSN-4125	A20563	STANDARD	1/30	115-127	.53	60	1100/3 SPD	CCW LEAD END	4125	

- NOTES:  
 1) MOTOR TO BE MOUNTED IN A HORZ. POSITION ONLY  
 2) USE WITH A 4 MFD/370 VAC CAPACITOR

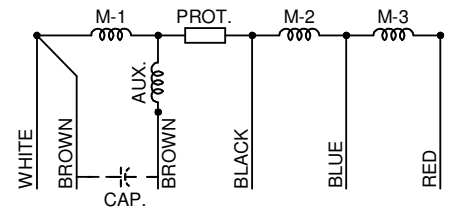
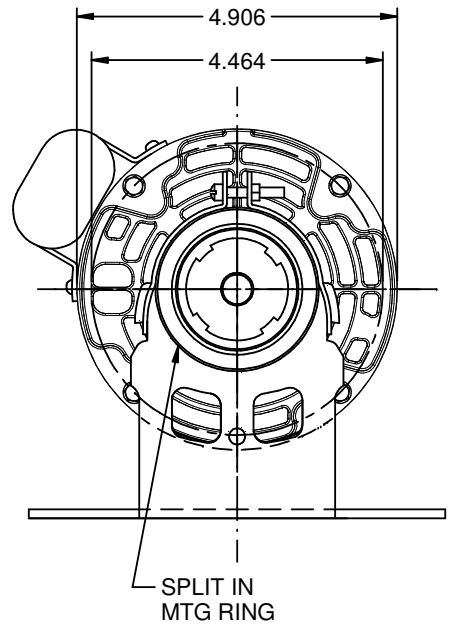
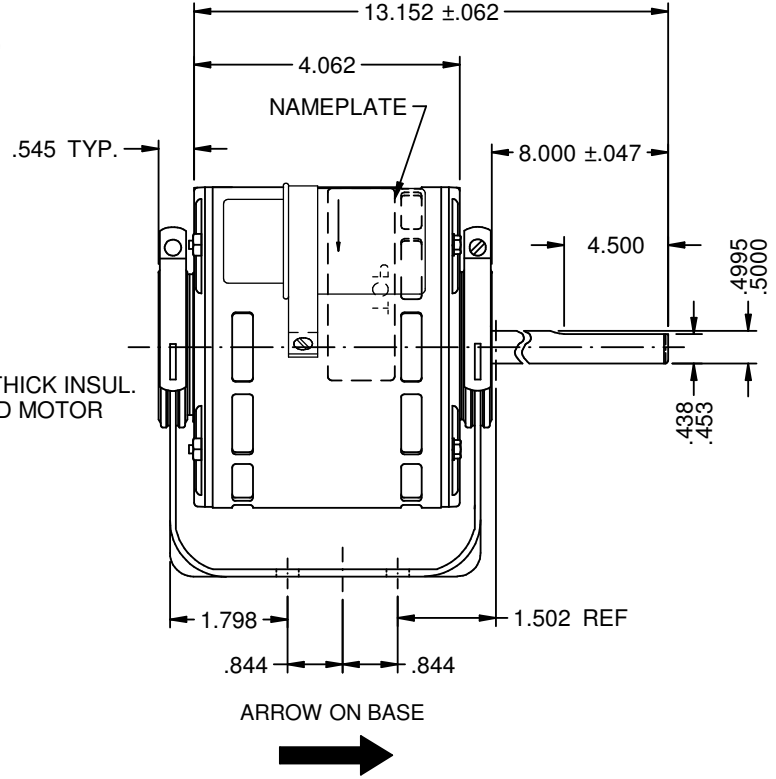
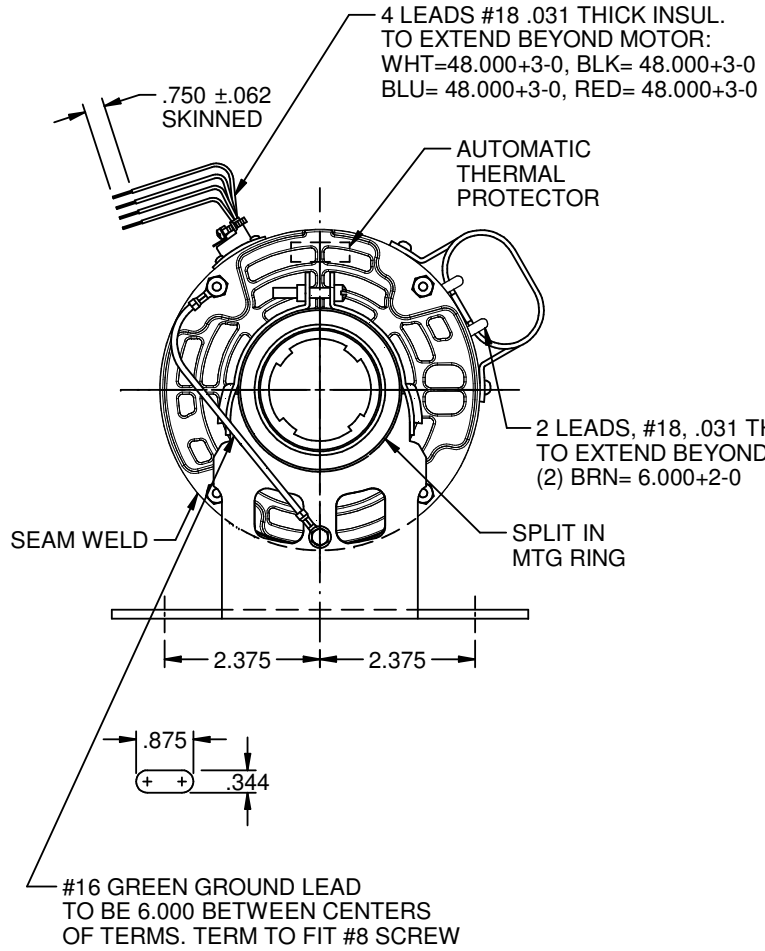

NIDEC MOTOR CORPORATION 23-May-17

REFER TO S.E.I.M. 24-1

REVISION RECORD FOR: E28697	
NEW DRAWING.	
ISSUED BY: B. ANDRADE	ENGINEER APPROVED: H. NAVARRO

DIMENSIONS ARE FOR REFERENCE ONLY

UNLESS TOLERANCE IS SPECIFIED

NIDEC MOTOR CORPORATION			
INFORMATION DISCLOSED ON THIS DOCUMENT IS CONSIDERED PROPRIETARY AND SHALL NOT BE REPRODUCED OR DISCLOSED WITHOUT WRITTEN CONSENT OF NIDEC MOTOR CORPORATION			
TITLE		CODE	REVISION DATE:
CUSTOMER DETAIL DRAWING	V02	17-MAY-17	
ITEM NO.	REV	SHEET NUMBER	DWG SIZE
815668	-	1 OF 3	B