

7 LEADS, #18, .031 THICK INSUL. TO EXTEND BEYOND MOTOR.
 WHT = 6.000±1.0, BLK = 6.000±1.0, PUR = 6.000±1.0,
 ORG = 6.000±1.0, BLU = 6.000±1.0, RED = 6.000±1.0,
 YEL = 6.000±1.0.
 LEADS TO BE DISCONNECTED AND BUNDLED UNDER TERM
 COVER IN INTERNAL CONDUIT BOX PRIOR TO SHIPMENT.

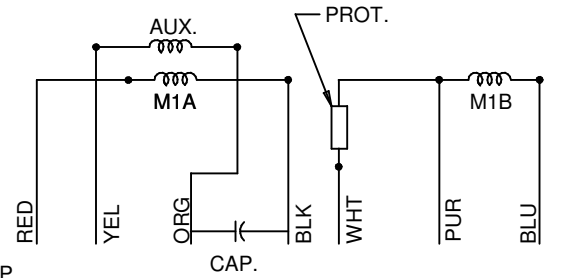
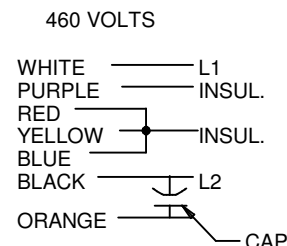
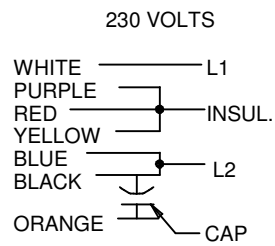
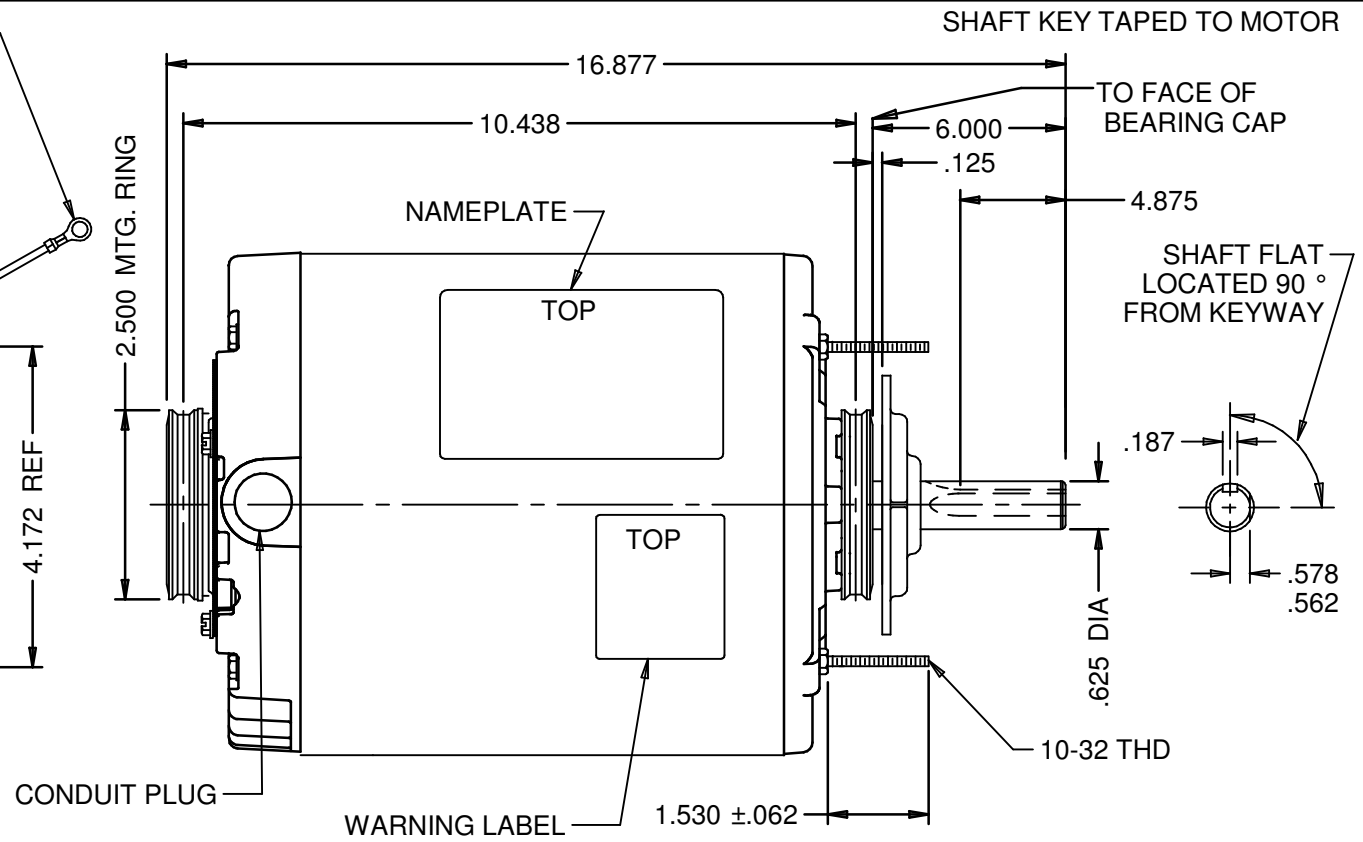

TO REVERSE ROTATION INTERCHANGE
 YELLOW AND ORANGE LEADS.

NIDEC MOTOR CORPORATION 22-Oct-12

MODEL	REF	CUSTOMER	HP	VOLTS	AMPS	HZ	RPM	ROTATION	CUSTOMER PN
K63ZZSYW-4625		STANDARD	1	208-230/460	5.5-5.1/2.6	60	1075	CCW LEAD END REV	2203

SHEET NUMBER	REV	REVISION RECORD FOR: C6406-00
1 OF 1	E	UPDATED "ENGINEER APPROVED" TO B. GAITAN
REVISION DATE		
22-OCT-12		

INFORMATION DISCLOSED ON THIS DOCUMENT IS CONSIDERED PROPRIETARY AND SHALL NOT BE REPRODUCED OR DISCLOSED WITHOUT WRITTEN CONSENT OF NIDEC MOTOR CORPORATION

NIDEC MOTOR CORPORATION

ISSUED BY	REVIEWED BY	ENGINEER APPROVED	REV.
B. ANDRADE	M. LARGENT	B. GAITAN	E

TITLE	CODE	ITEM NO.	SIZE
ASSEMBLED VIEW	V01	332751	A