

MODEL	REF	CUSTOMER	HP	VOLTS	AMPS	HZ	RPM	ROTATION	CUSTOMER PN	DESCRIPTION / REMARKS
K48HXTBD-3640		TRANE	1/15	115	0.8	60	1100/3 SPD	CW LEAD END	1090	K48 RESILIENT MOUNT, SELF ALIGN BEARING, OPEN.

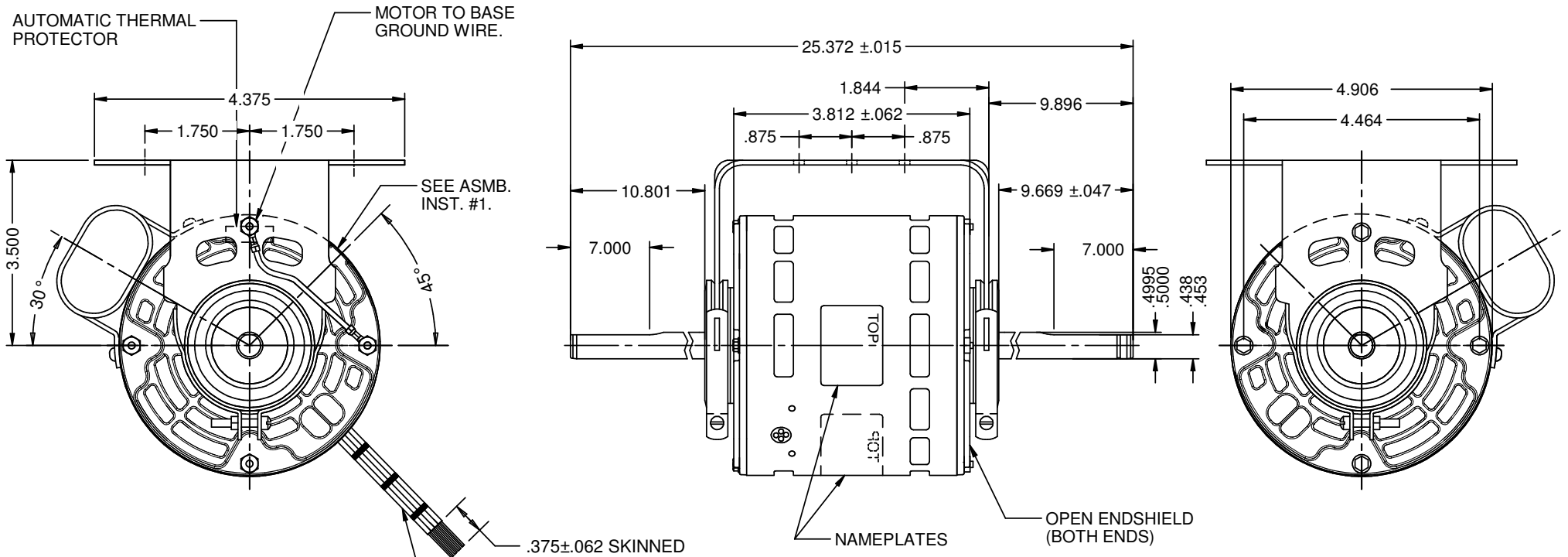

4 LEADS, #18, .031 THICK INSUL. TO EXTEND BEYOND MOTOR:
 BLACK= 44.000 +3-0, RED= 44.000 +3-0,
 WHITE= 44.000 +3-0, BLUE= 44.000 +3-0.
 LEADS TO BE TIE WRAPPED EVERY 10.000".

REV. A

NIDEC MOTOR CORPORATION 18-Jun-18

REFER TO S.E.I.M. 24-1

REVISION RECORD FOR:	E31122
CHANGED THE THICK OF INSULATION TO .031.	
UPDATED BACKGROUND OF V02.	
CHANGED DIAGRAM TO PAGE 3.	
ISSUED BY:	G. ISASSI
ENGINEER APPROVED:	J. RICE

DIMENSIONS ARE FOR REFERENCE ONLY
 UNLESS TOLERANCE IS SPECIFIED

NIDEC MOTOR CORPORATION			
INFORMATION DISCLOSED ON THIS DOCUMENT IS CONSIDERED PROPRIETARY AND SHALL NOT BE REPRODUCED OR DISCLOSED WITHOUT WRITTEN CONSENT OF NIDEC MOTOR CORPORATION			REVISION DATE: 18-JUN-18
TITLE	CODE	ITEM NO.	REV
CUSTOMER DETAIL DRAWING	V02	807117	A
		SHEET NUMBER	DWG SIZE
		1 OF 3	B