

104963

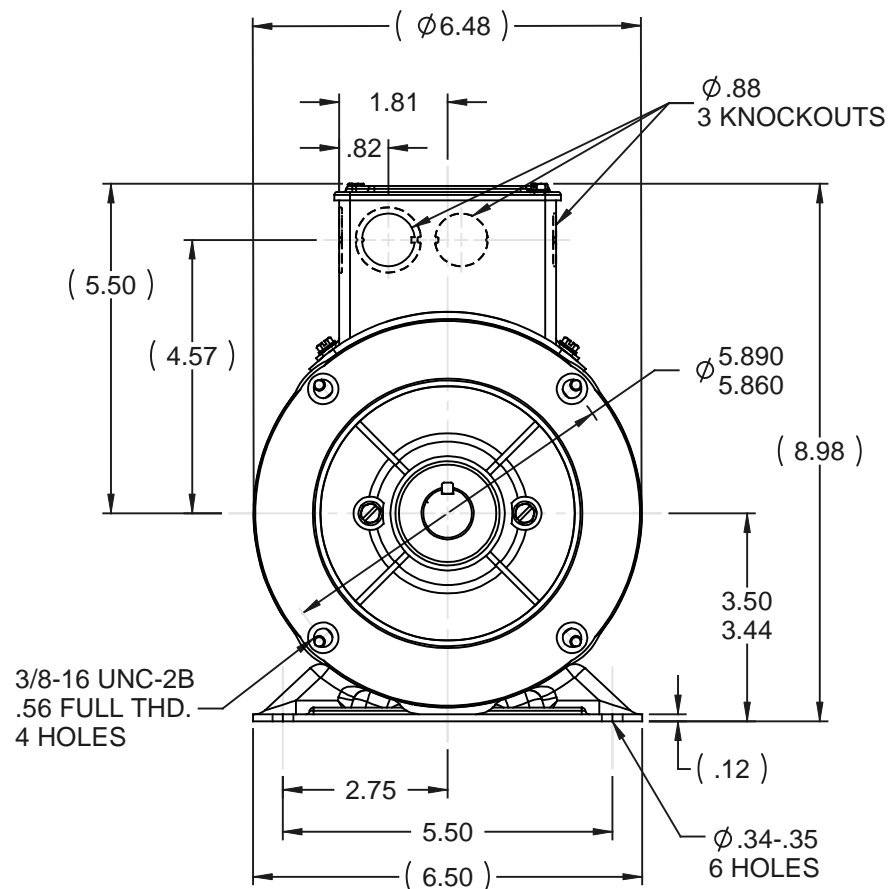
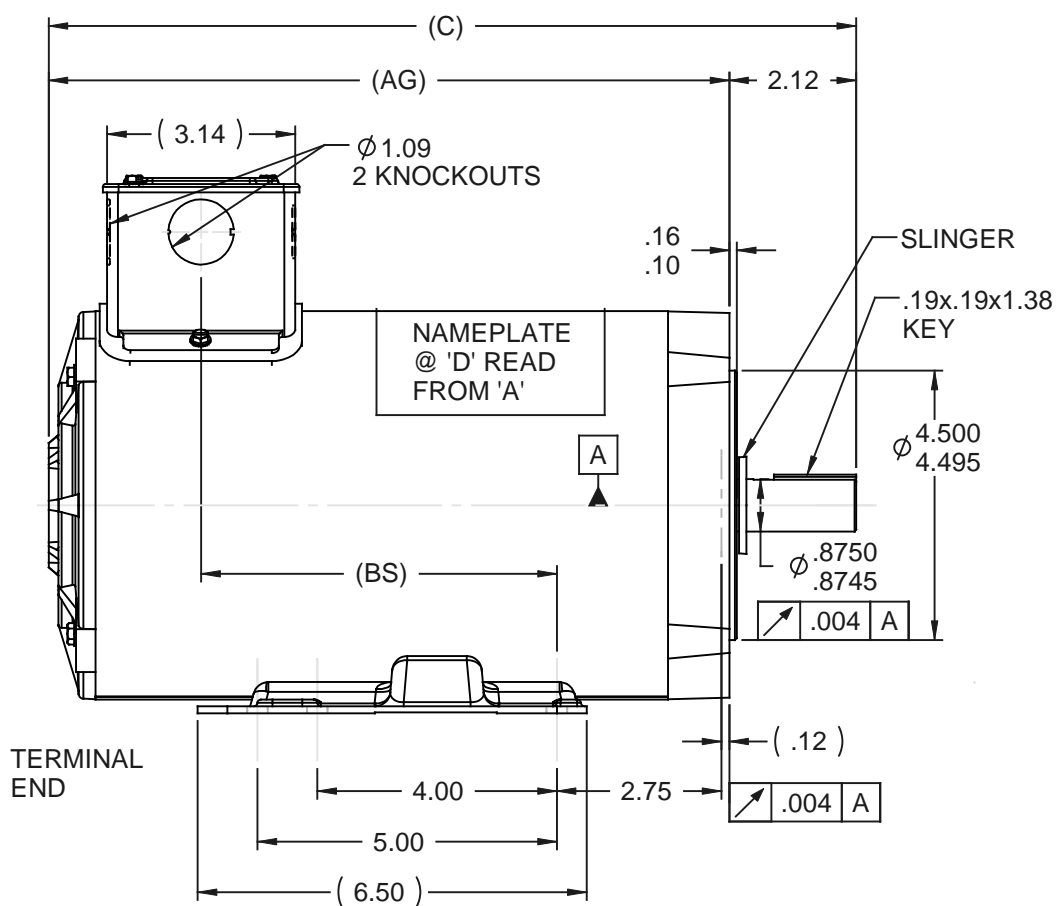

NOTE:  
CONDUIT BOX CAN BE ROTATED IN 180° STEPS

DASH	FRAME	C	AG	BS	DASH	FRAME	C	AG	BS
706	140T	10.98	8.86	3.44	856	140T	12.48	10.36	4.94
756	140T	11.48	9.36	3.94	906	140T	12.98	10.86	5.44
806	140T	11.98	9.86	4.44	956	140T	13.48	11.36	5.94

		TOLERANCES UNLESS SPECIFIED		DRAWN TJB 05-17-2001	
		DEC	INCHES	CHK	DRS 06-22-2001
4	REDRAWN ON SOLIDWORKS	DRS	.X ±.1	APPR	SAS 06-22-2001
3	REDRAWN ON AUTOCAD	TAT 07-06-2004	ML .XX ±.03	SCALE	5:16
2	TENV WAS TEFC IN TITLE BLOCK MU39147	DRS 10-24-2001	.XXX ±.005	REF	A-100106
1	NEW DRAWING MU37406	TJB 06-22-2001	.XXXX ±.0005	FMF	
NO	REVISION	BY & DATE	CHK ANG ±7'30"	PREV	
THIS DRAWING IN DESIGN AND DETAIL IS OUR PROPERTY AND MUST NOT BE USED EXCEPT IN CONNECTION WITH OUR WORK. ALL RIGHTS OF DESIGN AND INVENTION ARE RESERVED. THIS IS AN ELECTRONICALLY GENERATED DOCUMENT - DO NOT SCALE THIS PRINT				RFP	CAD FILE 104963
				SIZE	DRAWING NO
				A	104963
				DIST	WP
				REV	4