

SHEET 1
REV 3
52A109679
SIZE DRAWING NO. A

THIRD ANGLE PROJECTION

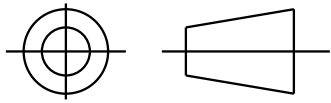

REVISIONS

REV.	DESCRIPTION	DATE	APPROVED
1	ADDED PARTS #2 & #3.	07/02/96	M.D.PAPE
2	ADDED PART #4.	10/10/97	M.D.PAPE
3	CHG TO RBC FORMAT PER ISO5-1777	03/23/06	SUDHA

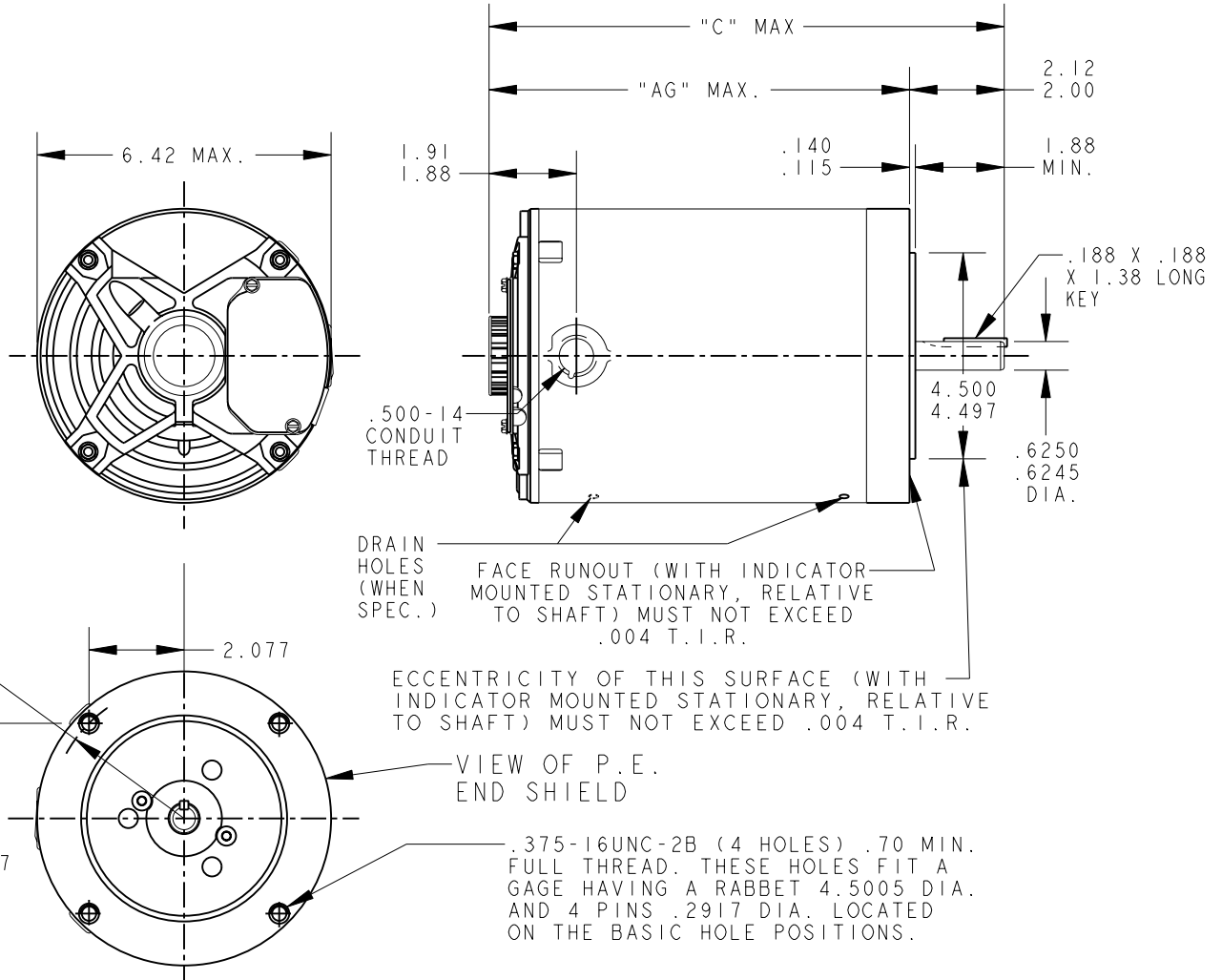

ALL DIMENSIONS ARE IN INCHES

4	K	42	56C	9.90	7.78	5.72
3	K	49	56C	10.33	8.21	6.15
2	K	46	56C	10.73	8.61	6.55
1	K	49	56C	9.52	7.40	5.34
P	TYPE	GE SIZE	NEMA FR.	"C"	"AG"	MIN. SHELL

SIGNATURES		DATE
MODEL	M.D.PAPE	09/12/94
DETAIL	.	.
CHECKED	.	.
ENGRG	.	.
MFG	.	.
FOR ADDITIONAL INFO REFER TO:	QUALITY	.
APPLIED PRACTICES	ISSUED	M.D.PAPE 09/12/94
DIMENSIONS ARE IN INCHES ✓	SOLID MODEL: 52A109679	



REGAL-BELOIT CORPORATION

TITLE

OUTLINE

GENERAL PURPOSE MOTOR TENV - BALL BEARING R2 END MOUNTED FMF - 40 FRAME REDESIGN

SIZE: DRAWING

A

SCALE: 0.250 REF. No: . SHEET 1 of 1

REV 3

52A109679