

DC MOTORS

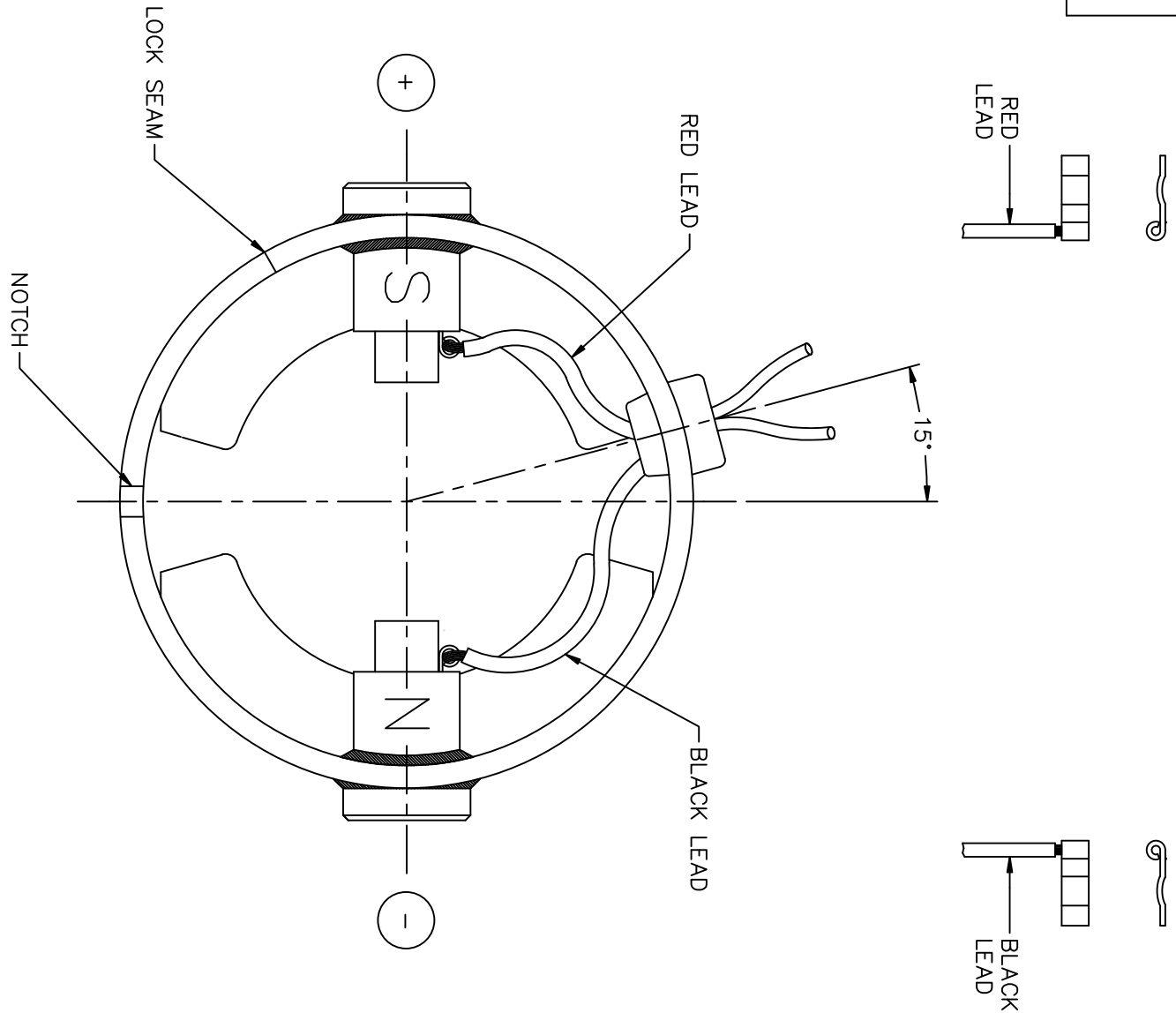

EXTERNAL CONNECTIONS FOR CCW ROTATION VIEWING
 LEAD END OF MOTOR WITH RED LEAD POSITIVE (+)
 AND BLACK LEAD NEGATIVE (-) FOR CW ROTATION
 POLARITY

				TOLERANCES UNLESS SPECIFIED		LEESON ELECTRIC MOTORS GEARMOTORS AND DRIVES	DRAWN PG 10/30/89
				DEC.	INCHES		CHK
				.X	±.1		APPD PW 10/31/89
03	REMOVED BARRIERS, NOT NEEDED, ISAAC 10-1959	IPG 5/14/2010	SK	.XX	±.01	TITLE CONNECTION DIAGRAM	SCALE 1=1
02	CORRECTED "N" & "S" PER ECR 83508	SMB 12/16/03	IPG	.XXX	±.005		REF 15008-01-117
01	REDRAWN ON CAD	AJR 06/30/99		.XXXX	±.0005	MAT'L.	FMF CM31D17NZ1
NO.	REVISION	BY & DATE	CHK	ANG	±1/2"	FINISH	PREV
THIS DRAWING IN DESIGN AND DETAIL IS OUR PROPERTY AND MUST NOT BE USED EXCEPT IN CONNECTION WITH OUR WORK ALL RIGHTS OF DESIGN AND INVENTION ARE RESERVED THIS IS AN ELECTRONICALLY GENERATED DOCUMENT - DO NOT SCALE THIS PRINT				RFP	CAD FILE	M100508401	SIZE DRAWING NO.
				DIST			A