

SS404049

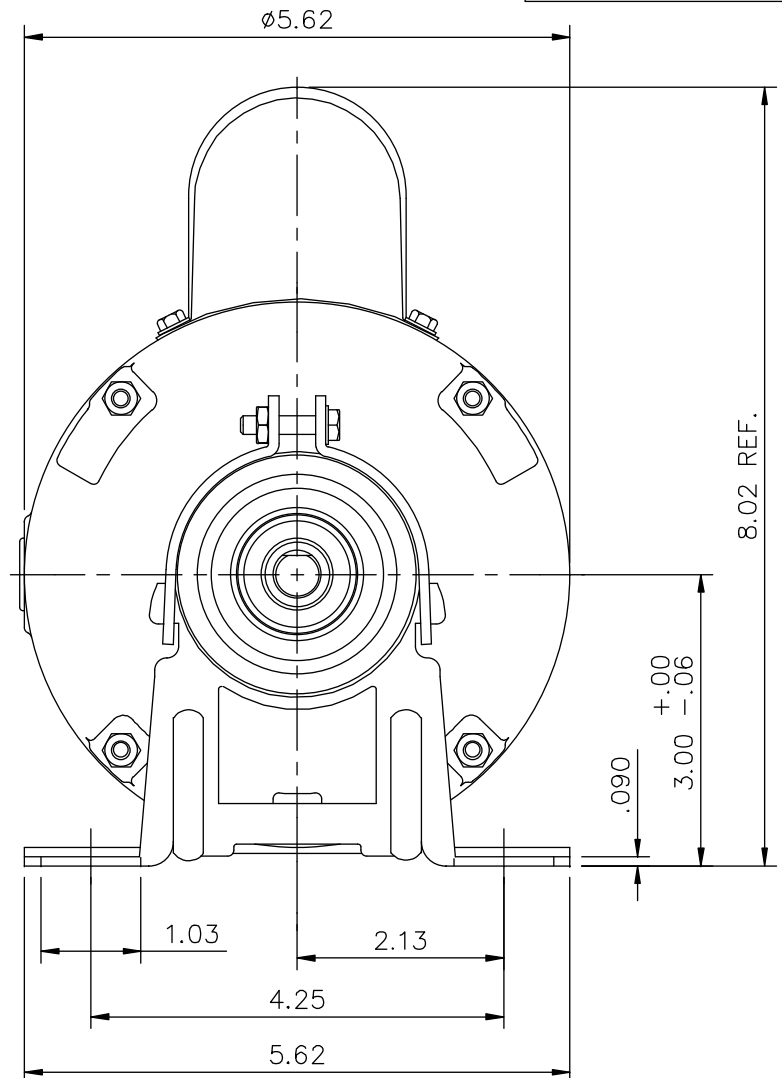

1/2-14 NPT
CONDUIT HOLE
(PLUGGED)

DASH NO.	"C"	"AD"
550	9.89	4.84
575	10.14	5.09
600	10.39	5.34
650	10.89	5.84

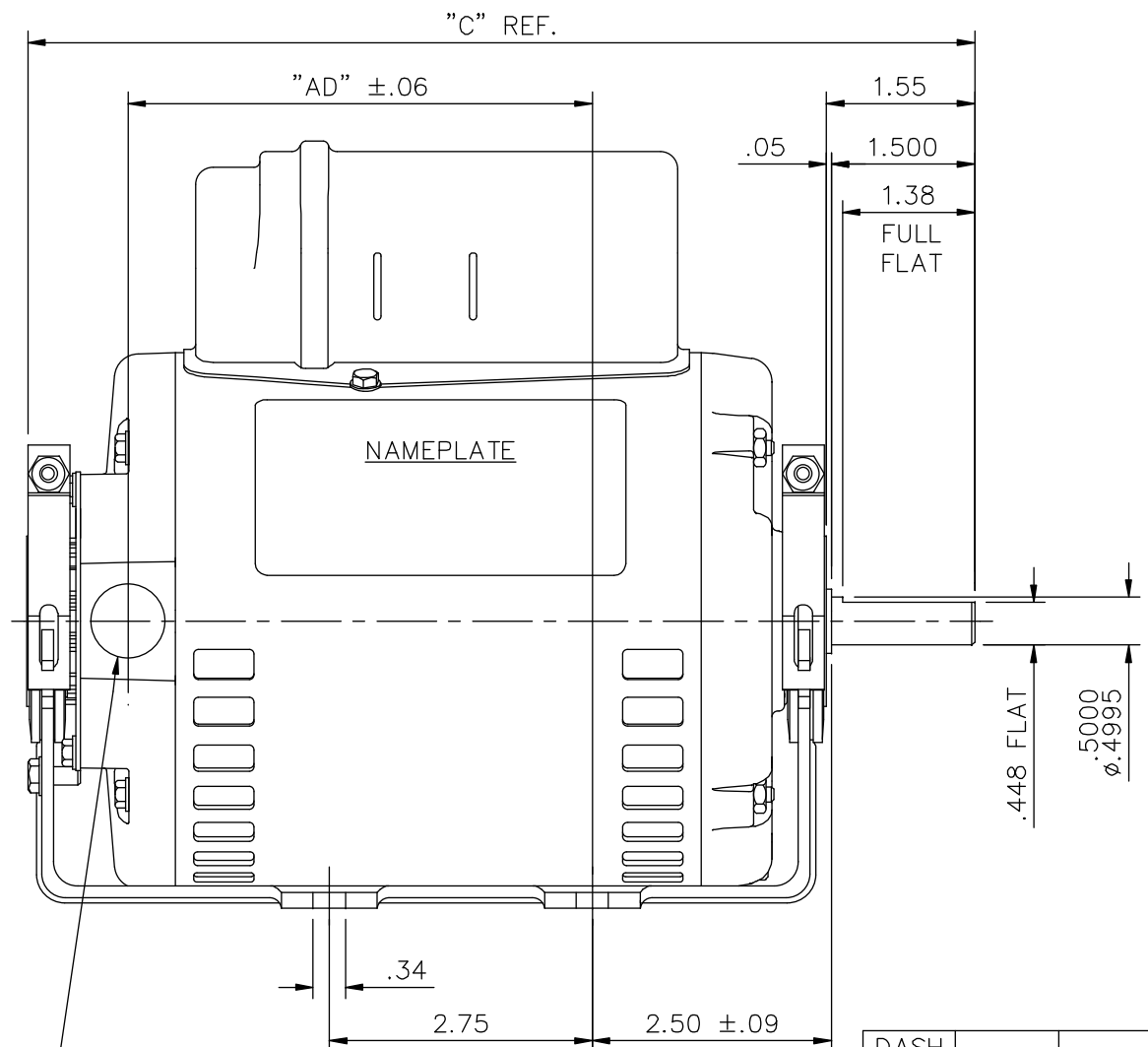

ELECTRIC MOTORS
GEARMOTORS
AND DRIVES

DRAWN	PST 11/27/13
CHK	SM 11/27/13
APPD	
SCALE	1:1
REF	031760
FMF	A090602.00
PREV	

TITLE
OUTLINE - 48 FRAME
RESILIENT MOUNT - DRIP PROOF
MAT'L.
1 PHASE
FINISH
STANDARD

NO.	REVISION	BY & DATE	CHK	TOLERANCES UNLESS SPECIFIED		ANG	RFP	CAD FILE	SS404049	SIZE	DRAWING NO.	REV.
				DEC.	INCHES							
				.X	±.1					A	SS404049	
				.XX	±.03							
				.XXX	±.005							
				.XXXX	±.0005							
				ANG	±1/2'							

THIS DRAWING IN DESIGN AND DETAIL IS OUR PROPERTY AND MUST NOT BE USED EXCEPT IN CONNECTION WITH OUR WORK ALL RIGHTS OF DESIGN AND INVENTION ARE RESERVED THIS IS AN ELECTRONICALLY GENERATED DOCUMENT - DO NOT SCALE THIS PRINT